

S450 / S452

Thermal Mass Flow Meter for Heavy Duty and Ex Applications

Insertion / Inline



S452

S450



INDUSTRIAL DESIGN
For outdoor applications



WIRELESS INTERFACE
User friendly sensor settings



NO MECHANICAL WEAR PARTS
Independent of pressure and temperature



EXPLOSION PROOF
Use in Ex-area applications



EASY TO CLEAN
All wetted parts stainless steel



ACCURATE RESULTS
Very fast response time



Benefits

- ✓ Robust metal enclosure suitable for outdoor applications in harsh environment
- ✓ All parts which come into contact with the measurement medium are made of stainless steel 316L
- ✓ No moving parts, non clogging
- ✓ Direct measurement of mass flow and standard flow without the need of pressure compensation
- ✓ Low maintenance costs due to stable and reliable measurements

1 Robust Materials

- The IP67 housing allows applications in harsh industrial environment as well as outdoor applications.
- All parts which come into contact with the measurement medium are made of stainless steel 316L. This makes the sensors robust and guarantees a reliable measurement.

2 Display

- The display shows all relevant measured values on site. This allows the user to install the flowmeter easily and quickly.
- The pressure-tight encapsulation protects the display from external influences and ensures that it is always clearly visible.

3 Flexible and easy Installation

Wide range of tube sizes are supported with insertion type for big pipe diameters and inline types for small pipe diameters.

4 Outputs

S450 and S452 offer different signal outputs for flexible installation. Analog 4 ... 20 mA 2/3-wire, pulse; Modbus/RTU; HART



Applications

- ✓ Flow measurement in hazardous and all wetter applications
- ✓ Explosive and harsh environments
- ✓ Pharmaceutical and food industry
- ✓ Various Gas Measurement such as oxygen, argon, carbon dioxide, natural gas, hydrogen, methane, etc..

Installation



S450

Insertion type installation through ball valve



S452

Inline type installation through flanges or R thread

Available Options

- ✓ Fieldbus interface: HART, M-Bus und Modbus/RTU
- ✓ Ex-Approvals:
 - IECEx
 - GB Ex
- ✓ Bi-directional measurement
- ✓ Flow conditioner for R-thread measuring sections

Rotation

Sensor head can be rotated in 90° steps through the screw nut. This allows the display to be turned into the best viewing position.



Industrial Communication

Industrial communication through Modbus/RTU, M-Bus, HART

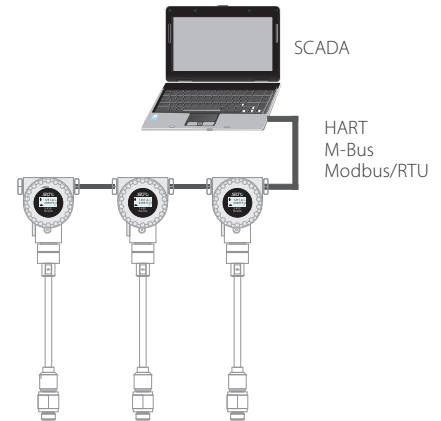

Volumetric Flow Ranges

Tube		S450 Volumetric Flow Ranges		
Inch	DN	S-Range (m³/h)	M-Range (m³/h)	HS-Range (m³/h)
½"	DN15	0.2 ... 45.6	0.4 ... 91.0	0.48 ... 110
¾"	DN20	0.4 ... 89.1	0.9 ... 178	1.09 ... 215
1"	DN25	0.6 ... 148	1.2 ... 295	1.82 ... 357
1½"	DN40	1.5 ... 367	2.9 ... 732	4.36 ... 886
2"	DN50	2.4 ... 600	4.8 ... 1,198	7.26 ... 1,450
2½"	DN65	4.1 ... 1,027	8.2 ... 2,049	12.1 ... 2,480
3"	DN80	5.7 ... 1,424	11.4 ... 2,841	16.9 ... 3,442
4"	DN100	8.7 ... 2,183	17.4 ... 4,357	24.2 ... 5,275
5"	DN125	20 ... 3,419	38 ... 6,824	45.9 ... 8,263
6"	DN150	20 ... 4,930	39 ... 9,839	70.18 ... 11,913
8"	DN200	35 ... 8,786	70 ... 17,533	106.48 ... 21,229
10"	DN250	55 ... 13,744	110 ... 27,429	165.77 ... 33,210
12"	DN300	79 ... 19,815	158 ... 39,544	239.58 ... 47,880

Tube		S452 Volumetric Flow Ranges		
Inch	DN	S-Range (m³/h)	M-Range (m³/h)	HS-Range (m³/h)
½"	DN15	0.2 ... 45.6	0.4 ... 91.0	0.48 ... 110
¾"	DN20	0.4 ... 89.1	0.9 ... 178	1.09 ... 215
1"	DN25	0.6 ... 148	1.2 ... 295	1.82 ... 357
1½"	DN40	1.5 ... 367	2.9 ... 732	4.36 ... 886
2"	DN50	2.4 ... 600	4.8 ... 1,198	7.26 ... 1,450
2½"	DN65	4.1 ... 1,027	8.2 ... 2,049	N/A
3"	DN80	5.7 ... 1,424	11.4 ... 2,841	N/A

Stated measuring ranges under following conditions:

- Standard flow in air
- Reference pressure: 1000 hpa reference temperature: +20 °c
- At other standard conditions and in other gases Flow ranges are different and data are available on request.
- In larger pipe diameters flow can also be measured.

S450 Dimensions

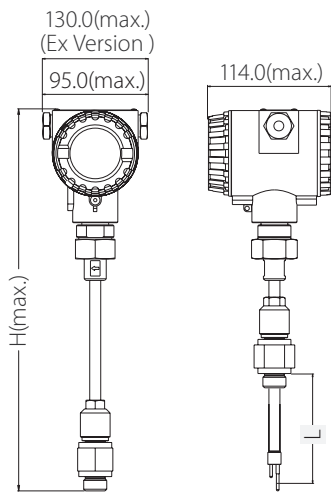

Shaft option	L (mm)	H (mm)
A	220	469
B	160	409
C	300	549

S452 Dimensions (Thread Type)

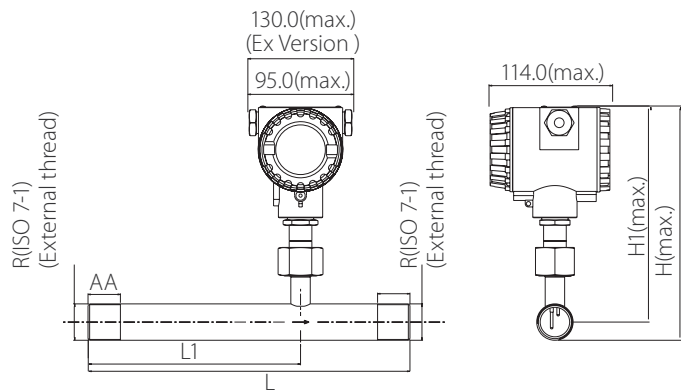

Pipe nominal size inch / (DN)	L total length (mm)	L1 inlet length (mm)	H total height (mm)	H1 pipe center to top (mm)	R External Thread
1/2" (DN15)	300	210	210.8	200.15	R 1/2"
3/4" (DN20)	475	275	213.6	200.15	R 3/4"
1" (DN25)	475	275	217.0	200.15	R 1"
1 1/4" (DN32)	475	275	221.35	200.15	R 1 1/4"
1 1/2" (DN40)	475	275	224.3	200.15	R 1 1/2"
2" (DN50)	475	275	230.3	200.15	R 2"
2 1/2" (DN65)	475	275	246.15	208.15	R 2 1/2"
3" (DN80)	475	275	259.15	214.65	R 3"

S452 Dimensions (Flange Type)

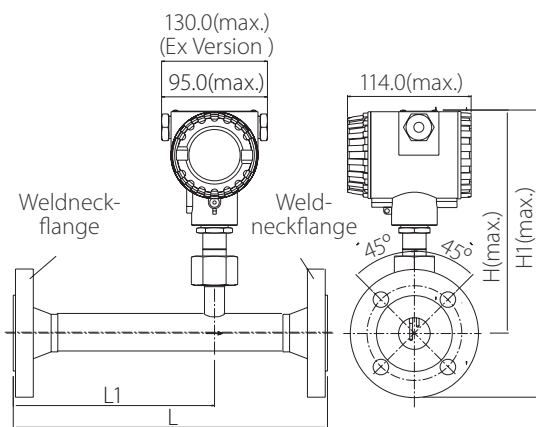

Pipe nominal size inch / (DN)	L total length (mm)	L1 inlet length (mm)	H total height (mm)	H1 pipe center to top (mm)
1/2" (DN15)	300	210	247.65	200.15
3/4" (DN20)	475	275	252.65	200.15
1" (DN25)	475	275	257.65	200.15
1 1/4" (DN32)	475	275	270.15	200.15
1 1/2" (DN40)	475	275	275.15	200.15
2" (DN50)	475	275	282.65	200.15
2 1/2" (DN65)	475	275	300.55	208.05
3" (DN80)	475	275	314.45	214.45

Technical Data

Measurement

Flow

Accuracy	±(1.5 % of reading + 0.3 % full scale)
Selectable units	m ³ /h, m ³ /min, l/min, l/s, cfm, kg/h, kg/min, kg/s
Repeatability	0.25 % o.RDG
Sensor	Thermal mass flow sensor
Sampling rate	3 samples / sec
Turndown ratio	200:1
Response time (t90)	0.5 sec

Consumption

Selectable units	m ³ , ft ³ , l, kg
------------------	--

Reference conditions

Selectable conditions	20 °C 1000 mbar (ISO1217), 0 °C 1013 mbar (DIN1343) freely adjustable
-----------------------	---

Signal / Interface & Supply

Analog output

Signal	4 ... 20 mA (4-wire), isolated
Scaling	0 ... max flow, freely adjustable
Load	Max. 400 Ohm
Update rate	Value updated ever 1 sec

Pulse output

Signal	Switch output, normally open, max. 30 VDC, 200 mA
Scaling	1 pulse per consumption unit (selectable)

Fieldbus

Protocol	Modbus/RTU, HART, M-Bus
----------	-------------------------

Supply

Voltage supply	16 ... 30 VDC
Current consumption	200 mA

General data

Configuration

PC Software	USB Service Kit + Software
-------------	----------------------------

Display

Integrated	LCD
------------	-----

Material

Process connection	Stainless steel 1.4404 (SUS 316L)
Housing	Al alloy
Sensor	Stainless steel 1.4404 (SUS 316L)
Metal parts	Stainless steel 1.4404 (SUS 316L)

Miscellaneous

Electrical connection	Screw terminals
Protection class	IP67
Approvals	CE, RoHS, FCC, Ex-Options
Process connection	S450: G1/2" (ISO 228/1) S452: Measuring section with R-thread or Flange
Weight	S450: 1.75 kg S452: 1.25 kg (without measuring section)

Operating conditions

Medium	Air, N ₂ , O ₂ , CO ₂ and other non corrosive gases
Medium temperature	S450: -40 ... +150 °C S452: -40 ... +100 °C
Medium humidity	< 90 %, no condensation
Operating pressure	S450: 0 ... 1.6 MPa (applicable for option A1280) 0 ... 5.0 MPa (applicable for option A1279)* S452: 0 ... 4.0 MPa *For pressure above 1.5 MPa use the installation device A530 1106 or A530 1113.
Ambient temperature	-40 ... +65 °C
Storage temperature	-30 ... +70 °C
Transport temperature	-30 ... 70 °C
Pipe sizes	S450: ½" ... 12" (bigger pipes on request) S452: ½" ... 3"

Ordering

Please use the following tables to assist in placing your order with our sales staff.

S450 Thermal Mass Flow Meter (Insertion type)

Order No.	Description
S695 0450	S450, Thermal Mass Flow Meter insertion type
Shaft length	
A1200	220 mm
A1201	160 mm
A1202	300 mm
Process connection	
A1006	PT 1/2" Adapter
A1005	NPT 1/2" Adapter
Gas type	
A1007	Air
A1008	CO ₂
A1009	O ₂ (Oil- & grease-free cleaned)
A1010	N ₂
A1011	N ₂ O
A1012	Argon
A1013	Natural Gas
A1014	H ₂ (real gas calibration)
A1015	Other gas (please specify)
A1016	He (real gas calibration)
A1017	C ₃ H ₈
A1041	O ₂ , Ar, CO ₂ (real gas calibration)
Range	
A1275	Standard
A1271	Max range
A1272	Bi-directional standard range
A1273	Bi-directional max. range
A1274	High speed
A1276	Low range version (1/3 of standard range)
Hazardous area approval	
A1279	None
A1280	IECEX / GB3836 Ex
Output	
A1284	2 x 4 ... 20 mA + pulse
A1285	1 x 4 ... 20 mA + HART + pulse
A1286	1 x 4 ... 20 mA + Modbus + pulse
Display	
A1294	Without display
A1295	With display

Attention:

* Measuring section connection and size must be combined to get the order number. Example: A1306 = R-thread DN50

S452 Thermal Mass Flow Meter (In-line type)

Order No.	Description
S695 0452	S452, Thermal Mass Flow Meter, inline type
Process connection *	
A130X	R-thread (ISO 7-1)
A132X	Flange EN 1092-1, PN40
A134X	Flange ANSI 16.5
Measuring section size *	
1	DN15 (1/2")
2	DN20 (3/4")
3	DN25 (1")
4	DN32 (1.25")
5	DN40 (1.5")
6	DN50 (2")
7	DN65 (2.5")
8	DN80 (3")
Gas type	
A1007	Air
A1008	CO ₂
A1009	O ₂ (Oil- & grease-free cleaned)
A1010	N ₂
A1011	N ₂ O
A1012	Argon
A1013	Natural Gas
A1014	H ₂ (real gas calibration)
A1015	Other gas (please specify)
A1016	He (real gas calibration)
A1017	C ₃ H ₈
A1041	O ₂ , Ar, CO ₂ (real gas calibration)
Range	
A1275	Standard
A1271	Max range
A1274	High speed (DN15 ... DN50)
A1276	Low range version (1/3 of standard range)
Hazardous area approval	
A1279	None
A1280	IECEX / GB3836 Ex
Output	
A1284	2 x 4 ... 20 mA + pulse
A1285	1 x 4 ... 20 mA + HART + pulse
A1286	1 x 4 ... 20 mA + Modbus + pulse
Display	
A1294	Without display
A1295	With display

Accessories

Order No.	Description
R200 0005	Oil- & grease-free cleaned option for flow sensors (for Oxygen it is already included in A 1009)
A530 1106	High pressure installation device S450, 220 mm (to be used if pressure above 1.5 MPa)
A530 1113	High pressure installation device S450, 400 mm (to be used if pressure above 1.5 MPa)



www.suto-itec.com



sales@suto-itec.com