

# Model 231 Multi-Sense® Wet-to-Wet Pressure Transducer



CE  
RoHS

SS231 Rev B05/31/07

setra

159, Swanson Road, Boxborough, MA 01719  
978-263-1400; 800-257-3872/www.setra.com; sales@setra.com



setra

978-263-1400; 800-257-3872  
www.setra.com; sales@setra.com

## 6.0 RETURNING PRODUCTS FOR REPAIR

Please contact a Setra application engineer (800-257-3872, 978-263-1400) before returning unit for repair to review information relative to your application. Many times only minor field adjustments may be necessary. When returning a product to Setra, the material should be carefully packaged, and shipped to :

Setra Systems, Inc.  
159 Swanson Road  
Boxborough, MA 01719-1304  
Attn: Repair Department

To assure prompt handling, returned unit(s) must be accompanied by Setra's Return Order Form, completely filled out, found on Setra's web site at [http://www.setra.com/tra/repairs/cal\\_rep.htm](http://www.setra.com/tra/repairs/cal_rep.htm).

Notes: Please remove any pressure fittings and plumbing that you have installed and enclose any required mating electrical connectors and wiring diagrams.

Allow approximately 3 weeks after receipt at Setra for the repair and return of the unit. Non-warranty repairs will not be made without customer approval and a purchase order to cover repair charges.

### Calibration Services

Setra maintains a complete calibration facility that is traceable to the National Institute of Standards & Technology (NIST). If you would like to recalibrate or recertify your Setra pressure transducers or transmitters, please call our Repair Department at 800-257-3872 (978-263-1400) for scheduling.

## 7.0 WARRANTY AND LIMITATION OF LIABILITY

SETRA warrants its products to be free from defects in materials and workmanship, subject to the following terms and conditions: Without charge, SETRA will repair or replace products found to be defective in materials or workmanship within the warranty period; provided that:

- a) the product has not been subjected to abuse, neglect, accident, incorrect wiring not our own, improper installation or servicing, or use in violation of instructions furnished by SETRA;
- b) the product has not been repaired or altered by anyone except SETRA or its authorized service agencies;
- c) the serial number or date code has not been removed, defaced, or otherwise changed; and
- d) examination discloses, in the judgment of SETRA, the defect in materials or workmanship developed under normal installation, use and service;
- e) SETRA is notified in advance of and the product is returned to SETRA transportation prepaid.

Unless otherwise specified in a manual or warranty card, or agreed to in writing and signed by a SETRA officer, SETRA pressure and acceleration products shall be warranted for one year from date of sale.

The foregoing warranty is in lieu of all warranties, express, implied or statutory, including but not limited to, any implied warranty of merchantability for a particular purpose.

SETRA's liability for breach of warranty is limited to repair or replacement, or if the goods cannot be repaired or replaced, to a refund of the purchase price. SETRA's liability for all other breaches is limited to a refund of the purchase price. In no instance shall SETRA be liable for incidental or consequential damages arising from a breach of warranty, or from the use or installation of its products.

No representative or person is authorized to give any warranty other than as set out above or to assume for SETRA any other liability in connection with the sale of its products.

## 5.0 OPERATION

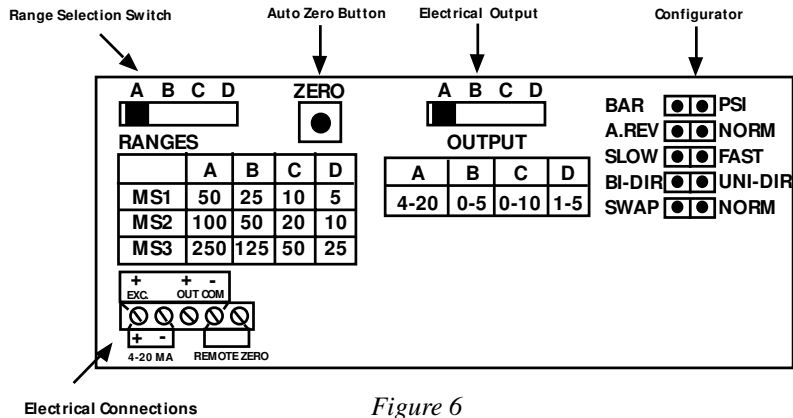

Figure 6

**Range Selection Switch:** The unit is set to the highest range when calibrated at the factory. To select the other ranges, slide the switch to the right. **Important: Push "zero" button after installing the Model 231, and after changing range.**

**Auto Zero Button:** Press and hold the "ZERO" push-button for 2 seconds to automatically reset zero or provide contact closure on "Remote Zero, see figure 4, pg.8, and figure 5, pg.9 .

**Electrical Output:** The unit is set at the factory to 4-20 mA. To select another output, move the slide switch to the right.

**Electrical Connections:** Electrical termination for power supply, 3-wire voltage output and 2-wire true 4-20 mA current output, and remote zero wiring.

**BAR/PSI:** Jumper selectable engineering units in Bar ranges or PSI.

### A. REV/NORM:

**A.REV:** Analog Reverse: When in reverse mode, the output increases when the differential pressure decreases and decreases as pressure increases.

**NORM:** When in Normal mode output increases as pressure increases and decreases as pressure decreases.

**SLOW/FAST:** When Slow mode is selected, 5-second averaging is provided for surge damping.

**BI-DIR/UNI-DIR:** Select UNI-Directional or BI-Directional mode.

Unidirectional mode measures from 0 to full scale differential pressure.

Bidirectional mode measures pressure from minus 1/2 of full scale to plus 1/2 of full scale differential pressure. Output will read 1/2 full scale when differential pressure is zero.

**SWAP/NORM:** Jumper selectable Port Swap feature eliminates costly replumbing when incorrectly installed or replaced. Go from NORMAL to SWAP and the jumper makes the "HI" Port "LO" and the "LO" port "HI".

# Contents

1.0 GENERAL INFORMATION .....	4
2.0 MECHANICAL INSTALLATION .....	4
2.1 Media compatibility .....	4
2.2 Environment .....	4
2.3 Pressure Fittings .....	5
2.4 Mounting .....	5
2.5 Installation Procedures .....	5
3.0 OPTIONAL 3-VALVE MANIFOLD PROCEDURE .....	6
4.0 ELECTRICAL INSTALLATION .....	8
4.1 Electrical Termination	
Wiring: 2-Wire , 4 to 20 mA and Remote Zero .....	8
4.2 Electrical Termination	
Wiring: 3-Wire, 0 to 5, 0 to 10, 1-5 VDC and Remote Zero .....	9
5.0 OPERATION .....	10
6.0 RETURNING PRODUCTS FOR REPAIR .....	11
7.0 WARRANTY AND LIMITATION OF LIABILITY .....	11

# Model 231

## Installation Guide

### Multi-Sense® Model 231 Series

#### Wet-to-Wet Differential Pressure Transducers

### 1.0 GENERAL INFORMATION

Every Model 231 has been calibrated and tested before shipment to guarantee performance of all pressure ranges.

The Model 231 has field selectable unidirectional and bidirectional pressure ranges, configurable 0 to 5 VDC, 0 to 10 VDC, and 1 to 5 VDC output, true two-wire 4 to 20 mA output, and auto-zero capability. The Model 231 is factory calibrated to the highest pressure range. The range label on the side of the unit indicates the factory calibrated range.

Setra Systems 231 pressure transducers sense differential pressure and convert this difference in pressure to a proportional high level analog output for unidirectional and bidirectional pressure ranges.

Your Model 231 Multi-Sense pressure transducer has been ordered in one of the following versions:

Version	Unidirectional	Bidirectional
MS1	5, 10, 20, 50 psid	±5, ±10, ±20, ±50 psid
MS2	10, 20, 50, 100 psid	±10, ±20, ±50, ±100 psid
MS3	25, 50, 125, 250 psid	±25, ±50, ±125, ±250 psid

### 2.0 MECHANICAL INSTALLATION

#### 2.1 Media compatibility

Model 231 transducers are designed to be used with any gas or liquid compatible with 17-4 PH stainless steel. The optional 3-valve manifold assembly is designed to be used with gases or liquids compatible with 360 Brass, Acetal plug valves and Nitrile O-Rings. Never totally submerge the unit in any liquid.

#### 2.2 Environment

The operating temperature limits of the 231 are as follows:

Compensated Temperature Range °F (°C)	+32 to +130 (0 to +54)
Operating Temperature Range °F (°C)	-4 to +185 (-20 to +85)
Storage Temperature Range °F (°C)	-4 to +185 (-20 to +85)

### 4.2 Electrical Termination

#### Wiring: 3-Wire, 0 to 5, 0 to 10, 1-5 VDC and Remote Zero

The Model 231 when configured for voltage output is a 3-wire circuit device with three terminals available for wiring. The -Excitation and -Output are commoned on the circuit.

The 231 can operate from 12-30 VDC (12-24 VAC) nominal output power supply.

*Note: The Zero terminals, connected to digital output, provide a contact closure relay for automatic reset to zero pressure by the monitoring system. CAUTION: ZERO input is for dry contact, do no apply voltage to ZERO Terminals*

The optional remote zero is a normally open relay wired between COM and REMOTE ZERO terminals. In order to initiate ZERO function the relay contact shall be closed.

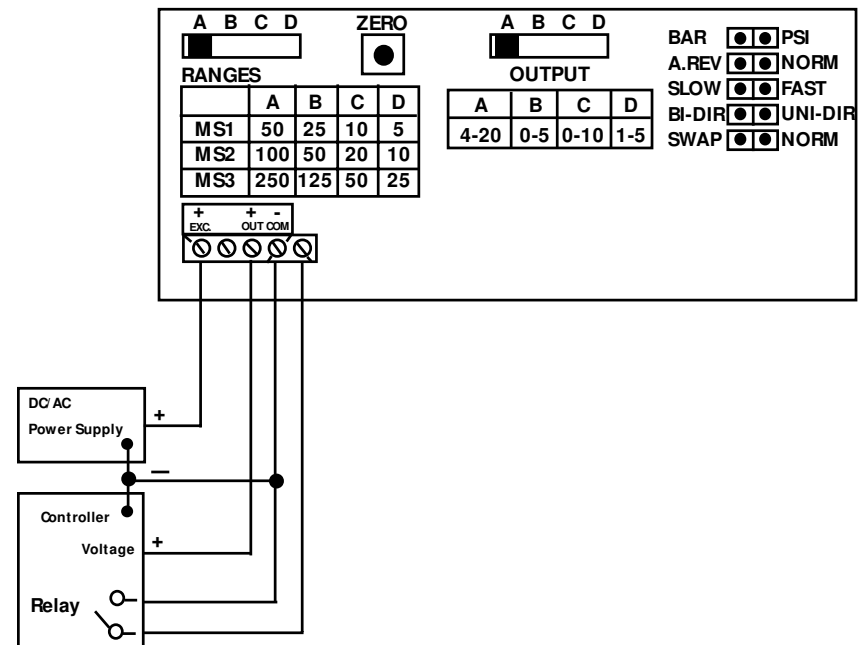

Figure 5

Installation of the Model 231 is now complete.

**Important: Prior to putting the unit into service, press the “Zero” button, then use the “Range Selection Switch” to select a range. After selecting a range, press the “Zero” button again. For instructions regarding operation of the Model 231, please refer to Section 5, page 10.**

## 4.0 ELECTRICAL INSTALLATION

To access the electrical connections, turn the screws on the top of the case counter clockwise until the hinged cover can be flipped up. The screws are captured and secured in the cover. Wiring is through the 1/2" conduit opening. Both current and voltage outputs are reverse wiring protected.

*Note: The Zero terminals, connected to digital output, provide a contact closure relay for automatic reset to zero pressure by the monitoring system. CAUTION: ZERO input is for dry contact, do no apply voltage to ZERO Terminals*

### 4.1 Electrical Termination

#### Wiring: 2-Wire - 4 to 20 mA (Current Output) and Remote Zero

Model 231 when configured as a current output transducer is a true 2-wire, 4-20 mA current output device and delivers rated current into any external load of 0-1000 ohms.

When configured as a 4-20 mA current output device the current flow is in one direction only. **PLEASE OBSERVE POLARITY.**

We suggest that an electrical cable shield be connected to the system's loop circuit ground to improve electrical noise rejection.

Min. Supply Voltage:  $12 + .02 \times (\text{Resistance of receiver plus line})$   
 Max. Supply Voltage:  $30 + .004 \times (\text{Resistance of receiver plus line})$

The optional remote zero is a normally open relay wired between COM and REMOTE ZERO terminals. In order to initiate ZERO function the relay contact shall be closed.

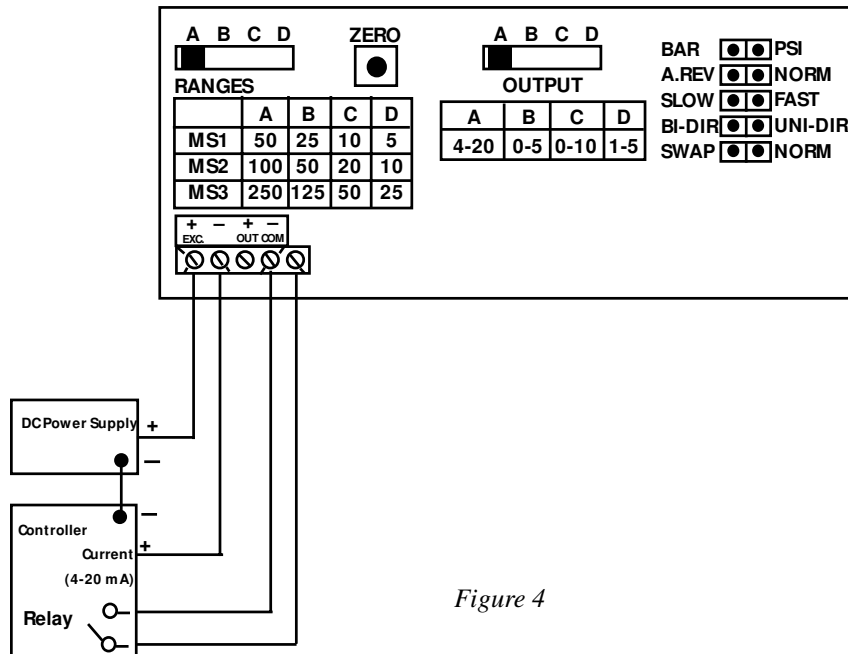

Figure 4

### 2.3 Pressure Fittings

Typically standard pipe fittings and installation procedures should be used.

The Model 231 has 1/8"–NPTF internal fittings. The high pressure port and low pressure port are located on the bottom of the unit, labeled "HI" and "LO", respectively. The optional 3-valve manifold assembly is supplied with 1/4"–18 NPT internal fittings.

#### Moisture Precautions

The Model 231 is provided with a 0.875 DIA. conduit opening for electrical termination, intended for a 1/2" I.D. conduit connection. This opening must be sealed according to standard industry practices in order to prevent moisture ingress into the Model 231.

### 2.4 Mounting

The Model 231 can be easily mounted using the two mounting screws located on the side of the unit.

### 2.5 Installation Procedures

If the Model 231 is supplied with an optional 3-valve Manifold assembly, refer to section 3.0, Optional 3-Valve Manifold Assembly Procedure, for further installation procedures. If the Model 231 is not supplied with a Setra 3-Valve manifold, the following installation procedure is recommended.

For differential pressure measurements at high line pressure, it is recommended that the pressure sensor be installed with a valve in each line, plus a shunt valve across the high and low (reference) pressure ports as shown.

**Important:** Do not exceed maximum range pressure with the total of differential pressure and line pressure.

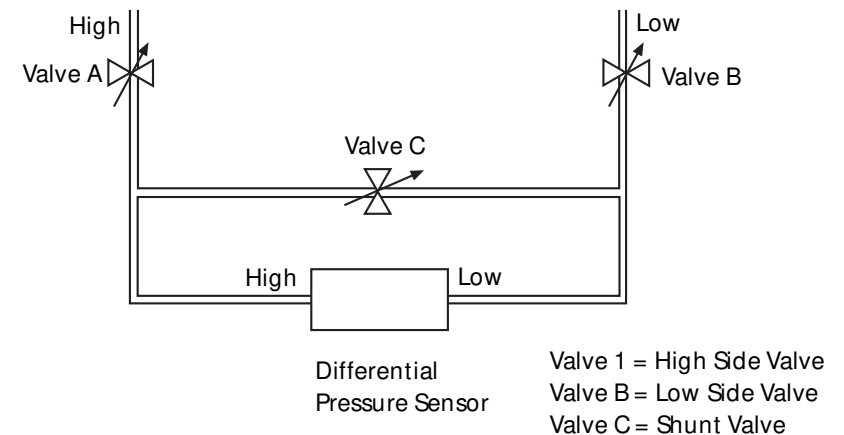
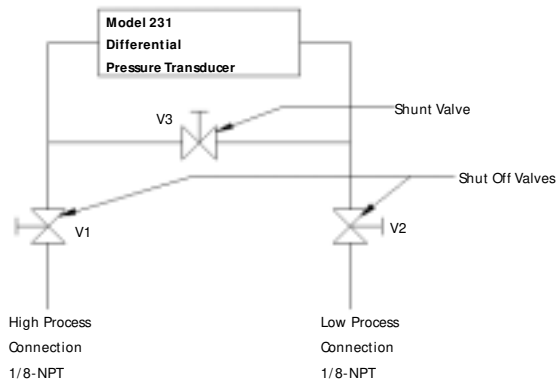

Figure 5



3-Valve Manifold Description	
Manifold Block	Brass
Valves (3)	V1 for connection to + port V2 for connection to - port V3 for equalizing pressure
Valve Type	90 degree On/Off
Process Connections	1/4-18NPT Internal Thread

Figure 2

### 3.0 OPTIONAL 3-VALVE MANIFOLD PROCEDURE

The 3-Valve Manifold Assembly is normally shipped with valves V1 and V2 closed and V3 open.

#### To Place the 231 into service:

1. Confirm valves V1 and V2 are closed and valve V3 is open.
2. Mount the manifold and install process connections.
3. Slowly open V2, then V1.
4. Close the V3 valve.

#### To Take the 231 out of Service

1. Open V3 to equalize the pressure at the Model 231.
2. Close the V1 and V2 valves.

## Model 231 - Outline Drawing

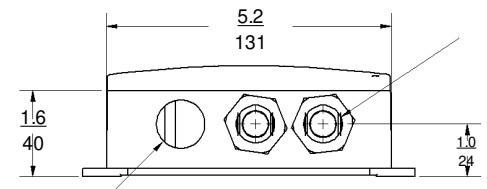
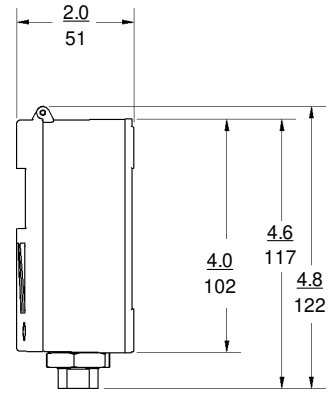
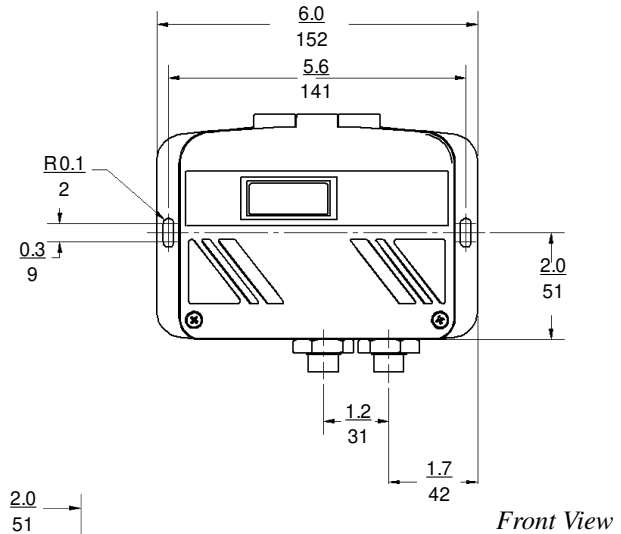

1/2" Conduit Opening

Bottom View

Figure 3

in.  
mm