

ProtEX-MAX PD8-7000 Explosion-Proof Temperature Meter Instruction Manual



Temperature

- Thermocouple: J, K, T, E, R, S, B, N, C
- RTD: 100 Ω Pt, 10 Ω Cu, 120 Ω Ni, 1000 Ω Pt inputs
- 1° or 0.1° Resolution
- Displays up to 3300 F
- Averages up to 10 RTD Sensors
- Automatic Cold Junction Compensation
- Modern, Sleek and Practical Enclosure
- Display Mountable at 0°, 90°, 180°, & 270° Degrees
- Explosion-Proof, IP68, NEMA 4X Enclosure
- SafeTouch® Through-Glass Button Programming
- Flanges for Wall or Pipe Mounting
- Superluminous Sunlight Readable Display
- Free USB Programming Software & Cable
- 2 or 4 Relays + Isolated 4-20 mA Output Options
- USB, RS-232, & RS-485 Serial Communication Options
- Input Power Options Include 85-265 VAC or 12-24 VDC

PRECISION DIGITAL CORPORATION

233 South Street • Hopkinton MA 01748 USA
Tel (800) 343-1001 • Fax (508) 655-8990

**PRECISION
DIGITAL**

www.predig.com

Disclaimer

The information contained in this document is subject to change without notice. Precision Digital makes no representations or warranties with respect to the contents hereof and specifically disclaims any implied warranties of merchantability or fitness for a particular purpose.



CAUTION: *Read complete instructions prior to installation and operation of the meter.*

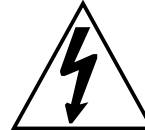

WARNING: *Risk of electric shock or personal injury.*



Warning!

- ***This product is not recommended for life support applications or applications where malfunctioning could result in personal injury or property loss. Anyone using this product for such applications does so at his/her own risk. Precision Digital Corporation shall not be held liable for damages resulting from such improper use.***
- ***Failure to follow installation guidelines could result in death or serious injury. Make sure only qualified personnel perform the installation.***
- ***Never remove the instrument cover in explosive environments when the circuit is live.***
- ***Cover must be fully engaged to meet flameproof/explosion-proof requirements.***
- ***Information in this manual supersedes all enclosure, compliance, and agency approval information included in additional product manuals included with this product.***

Limited Warranty

Precision Digital Corporation warrants this product against defects in material or workmanship for the specified period under "Specifications" from the date of shipment from the factory. Precision Digital's liability under this limited warranty shall not exceed the purchase value, repair, or replacement of the defective unit.

Registered Trademarks

MeterView® Pro is a registered trademark of Precision Digital Corporation. All other trademarks mentioned in this document are the property of their respective owners.

© 2018 Precision Digital Corporation. All rights reserved.

www.predig.com

Table of Contents

Table of Contents	3	Setting the Relay Action	31
Table of Figures	4	Programming Set and Reset Points	31
Introduction	4	Setting Fail-Safe Operation	31
Ordering Information	5	Programming Time Delay	31
Specifications	6	Relay Action for Loss of Input (Input Break)	31
General	6	Relay and Alarm Operation Diagrams	32
Temperature Input	7	High Alarm Operation (Set > Reset)	32
Relays	7	Low Alarm Operation (Set < Reset)	32
Isolated 4-20 mA Output	8	High Alarm with Fail-Safe Operation (Set > Reset)	32
Serial Communications	8	32
Digital Inputs & Outputs	8	Low Alarm with Fail-Safe Operation (Set < Reset)	32
MeterView Pro	8	Pump Alternation Control Operation	33
Product Ratings and Approvals;	9	Relay Sampling Operation	33
Compliance Information	10	Signal Loss or Input Break Relay Operation	34
Safety	10	Time Delay Operation	34
Electromagnetic Compatibility	10	Relay Operation Details	35
Safety Information	11	Overview	35
Installation	11	Relays Auto Initialization	35
Unpacking	11	Fail-Safe Operation	35
Pre-Installed Conduit/Stopping Plug	12	Front Panel LEDs	35
Mounting	12	Latching and Non-Latching Relay Operation	36
Cover Jam Screw	12	Non-Latching Relay (R _{uLta})	36
Connections	13	Non-Latching Relay (R _{nonRn})	36
Required & Factory Wired Connection	13	Latching Relay (LR _{LCH})	36
Connectors Labeling	14	Latching Relay (LR _{Lr})	36
Power Connections	14	Acknowledging Relays	37
Signal Connections	15	Setting Up the Interlock Relay (Force On) Feature	37
Connections for Averaging RTD Sensors	16	Scaling the 4-20 mA Analog Output (R_{out})	38
Serial Communications Connections	16	Reset Menu (rESEt)	38
Using PROVU Serial Adapters	18	Control Menu (ConTrL)	38
Relay Connections	19	Setting Up the Password (PASS)	39
Switching Inductive Loads	19	Protecting or Locking the Meter	39
F4 Digital Input Connections	20	Making Changes to a Password Protected Meter	39
4-20 mA Output Connections	20	Disabling Password Protection	39
Power Supply for Analog Output Loop or Other	20	Advanced Features Menu	40
Uses	20	Advanced Features Menu & Display Messages	40
Interlock Relay Feature	20	Offset Adjust (AdjUSt)	41
Digital I/O Connections	21	Recalibration of the Meter (LR _L)	42
External Switch Contacts	21	Noise Filter (F _{ILtEr})	43
Setup and Programming	22	Noise Filter Bypass (bYPASS)	43
SafeTouch® Buttons	22	Rounding Feature (rouNd)	43
Front Buttons and Status LED Indicators	23	Modbus RTU Serial Communications (SEr _r RL)	43
MeterView® Pro Software	24	Serial Communications Overview	44
MeterView Pro Installation	24	Select Menu (SELEct)	45
Display Functions & Messages	25	Analog Output Programming (R _{outPr})	45
Main Menu	27	Programmable Function Keys User Menu (uSEr)	46
Setting Numeric Values	27	Internal Temperature Calibration (IR _L)	47
Setting Up the Meter (SEtUP)	28	Meter Operation	49
Setting the Input Signal (InPUt)	29	Front Buttons Operation	49
Selecting the Temperature Scale (F or C)	29	SafeTouch® Buttons	49
Setting the Decimal Point (dEc _{Pt})	29	F4 Operation	50
Setting the Display Parameter & Intensity (dSP _L RY)	29	Maximum/Minimum Readings	50
.....	29	Troubleshooting	51
Setting the Input Units or Custom Tags (un _{It} S)	30	Diagnostics Menu (d_rLG)	51
Setting the Relay Operation (rEL _{RY})	30	Determining Software Version	51
		Reset Meter to Factory Defaults	51

Factory Defaults & User Settings-----	52	Mounting Dimensions -----	55
Troubleshooting Tips -----	53	EU Declaration of Conformity -----	57
Service -----	54		

Table of Figures

Figure 1: Integrated ProVu Required Connections ..	13	Figure 13. Relay Connections.....	19
Figure 2. Connector Labeling for Fully Loaded PD8-7000	14	Figure 14. AC and DC Loads Protection	19
Figure 3. Power Connections.....	14	Figure 15. Low Voltage DC Loads Protection	19
Figure 4. Thermocouple Input Connections	15	Figure 16. F4 Digital Input Connections	20
Figure 5. Three-Wire RTD Input Connections.....	15	Figure 17. 4-20 mA Output Connections.....	20
Figure 6. Two-Wire RTD Input Connections	15	Figure 18. Interlock Connections	20
Figure 7. Four-Wire RTD Input Connections.....	15	Figure 19: Digital I/O Connections	21
Figure 8. Average Temperature RTD Input Connections	16	Figure 20. Acknowledge Relays w/Function Key or Digital Input	37
Figure 9: ProtEX-MAX Connections to a Serial Converter	16	Figure 21: General Four-Wire Network Connection..	44
Figure 10. Three-Wire RS485 Connection	16	Figure 22: General Two-Wire Network Connection...	44
Figure 11: RS-485 Wiring.....	17	Figure 23: Enclosure Dimensions – Front View	55
Figure 12: RS-485 Two-Wire Multi-Drop Wiring	18	Figure 24: Enclosure Dimensions – Side Cross Section View.....	55

Introduction

The ProtEX-MAX PD8-7000 offers all the functionality of the ProVu PD7000 as a fully FM, CSA, ATEX, and IECEx approved explosion-proof product. It accepts a direct temperature input from a wide range of temperature measurement devices (type J, K, T, E, R, S, B, N, and C thermocouples and 100 or 1000 Ω platinum, 10 Ω copper, 120 Ω nickel RTDs). It displays the measured temperature in either degrees Fahrenheit or degrees Celsius on a dual-line, 6-digit SunBright® sunlight readable display. The meter includes automatic cold junction compensation for thermocouples and the ability to average up to ten (10) RTD sensors. The PD8-7000 can be equipped with up to four internal relays and a 4-20 mA analog output. It can be programmed and operated without opening the housing by using the built-in SafeTouch® through-glass buttons or the RS485 serial communication port with free Modbus® protocol.

Ordering Information

SunBright Display Models

85-265 VAC Model	12-24 VDC Model	Options Installed
PD8-7000-6H0	PD8-7000-7H0	No options
PD8-7000-6H2	PD8-7000-7H2	2 relays
PD8-7000-6H3	PD8-7000-7H3	4-20 mA output
PD8-7000-6H4	PD8-7000-7H4	4 relays
PD8-7000-6H5	PD8-7000-7H5	2 relays & 4-20 mA output
PD8-7000-6H7	PD8-7000-7H7	4 relays & 4-20 mA output

Accessories

Model	Description
PDA1232	RS-232 serial adapter
PDA1485	RS-485 serial adapter
PDA7485-I	RS-232 to RS-422/485 isolated converter
PDA7485-N	RS-232 to RS-422/485 non-isolated converter
PDA8232-N	USB to RS-232 non-isolated converter
PDA8485-I	USB to RS-422/485 isolated converter
PDA8485-N	USB to RS-422/485 non-isolated converter
PDX6901	Suppressor (snubber): 0.01 μ F/470 Ω , 250 VAC

Specifications

Except where noted all specifications apply to operation at +25°C.

General

Display	Line 1: 0.60" (15 mm) high red LEDs; Line 2: 0.46" (12 mm) high red LEDs. Both displays have six characters with leading zero blanking. Temperature value is four or five-digit F/C, based on configuration.
Resolution	1° or 0.1° for all thermocouples and RTD inputs
Display Intensity	Eight user selectable intensity levels
Display Update Rate	5/second (200 ms)
Overrange	Display flashes 99999
Underrange	Display flashes -9999
Programming Methods	Four front panel buttons, digital inputs, PC and MeterView® Pro software, or Modbus registers.
Noise Filter	Programmable from 2 to 199 (0 will disable filter)
Filter Bypass	Programmable from 0.1 to 99.9% of calibrated span
Recalibration	All ranges are calibrated at the factory. Recalibration is recommended at least every 12 months.
Max/Min Display	Max/min readings reached by the process are stored until reset by the user or until power to the meter is cycled.
Password	Three programmable passwords restrict modification of programmed settings. Pass 1: Allows use of function keys and digital inputs Pass 2: Allows use of function keys, digital inputs and editing set/reset points Pass 3: Restricts all programming, function keys, and digital inputs.
Non-Volatile Memory	All programmed settings are stored in non-volatile memory for a minimum of ten years if power is lost.
Power Options	85-265 VAC 50/60 Hz, 90-265 VDC, 20 W max or 12-24 VDC ± 10%, 15 W max Powered over USB for configuration only
Fuse	Required external fuse: UL Recognized, 5 A max, slow blow; up to 6 meters may share one 5 A fuse
Normal Mode Rejection	Greater than 60 dB at 50/60 Hz
Isolation	4 kV input/output-to-power line 500 V input-to-output
Overvoltage Category	Installation Overvoltage Category II: Local level with smaller transient overvoltages than Installation Overvoltage Category III.
Environmental	T6 Class operating temperature range Ta = -20 to 60°C T5 Class operating temperature range Ta = -20 to 65°C

Max Power Dissipation	Maximum power dissipation limited to 15.1 W.
Connections	Screw terminals accept 12 to 22 AWG wire
Enclosure	Explosion-proof die cast aluminum with glass window, corrosion resistant epoxy coating, color: blue. NEMA 4X, 7, & 9, IP68. Default conduit connections: Four ¾" NPT threaded conduit openings and two ¾" NPT metal conduit plugs with 12 mm hex key fitting installed. Additional conduit opening configurations may be available; verify quantity and sizes on specific device labeling during installation.
Mounting	Four slotted flanges for wall mounting or NPS 1½" to 2½" or DN 40 to 65 mm pipe mounting. See Mounting Dimensions on page 55.
Tightening Torque	Screw terminal connectors: 5 lb-in (0.56 Nm)
Overall Dimensions	6.42" x 7.97" x 8.47" (W x H x D) (163 mm x 202 mm x 215 mm)
Weight	16.0 lbs (7.26 kg)
Warranty	3 years parts & labor
F4 Digital Input Contacts	3.3 VDC on contact. Connect normally open contacts across F4 to COM.
F4 Digital Input Logic Levels	Logic High: 3 to 5 VDC Logic Low: 0 to 1.25 VDC

Temperature Input

Inputs	Thermocouple: J, K, T, E, R, S, B, N, C; RTD: 100 Ω platinum (0.00385 & 0.00392 coefficients), 10 Ω copper, 120 Ω nickel, 1000 Ω platinum (0.00385 & 0.00392 coefficients)
Cold Junction Reference	Automatic, fixed, no user calibration needed
Temperature Drift	$\pm 2^{\circ}\text{C}$ maximum from 0 to 65°C ambient temperature $\pm 4^{\circ}\text{C}$ maximum from -20 to 0°C ambient temperature
Offset Adjustment	User programmable offset adjust ± 50.0 degrees. This parameter allows the user to apply an offset value to the temperature being displayed.
Input Impedance	Greater than 100 k Ω
Sensor Break Detection	Open TC or RTD sensor indicated by display flashing oPEr , relays can be programmed to go "On", "Off", or to "Ignore" (<i>Note: Ignore is detected as an upscale condition</i>). Analog output goes to the programmed sensor break value.
RTD Averaging	Up to 10 RTDs connected in parallel can be averaged.

Accuracy & Ranges

Type	Range (°F)	Accuracy	Range (°C)	Accuracy
J	-200 to 2000	$\pm 1.8^{\circ}\text{F}$	-129 to 1093	$\pm 1^{\circ}\text{C}$
K	-200 to 2400	$\pm 1.8^{\circ}\text{F}$	-129 to 1316	$\pm 1^{\circ}\text{C}$
T	-200 to 752	$\pm 1.8^{\circ}\text{F}$	-129 to 400	$\pm 1^{\circ}\text{C}$
E	-200 to 1800	$\pm 1.8^{\circ}\text{F}$	-129 to 982	$\pm 1^{\circ}\text{C}$
R	-50 to 3000	$\pm 3.6^{\circ}\text{F}$	-46 to 1649	$\pm 2^{\circ}\text{C}$
S	-50 to 3000	$\pm 3.6^{\circ}\text{F}$	-46 to 1649	$\pm 2^{\circ}\text{C}$
B	752 to 3300	$\pm 3.6^{\circ}\text{F}$	400 to 1816	$\pm 2^{\circ}\text{C}$
N	-100 to 2300	$\pm 3.6^{\circ}\text{F}$	-73 to 1260	$\pm 2^{\circ}\text{C}$
C	32 to 4100	$\pm 3.6^{\circ}\text{F}$	0 to 2260	$\pm 2^{\circ}\text{C}$
10 Ω	-328 to 500	$\pm 0.2^{\circ}\text{F}$	-200 to 260	$\pm 0.1^{\circ}\text{C}$
100 Ω	-328 to 1562	$\pm 0.7^{\circ}\text{F}$	-200 to 850	$\pm 0.4^{\circ}\text{C}$
120 Ω	-110 to 500	$\pm 0.2^{\circ}\text{F}$	-79 to 260	$\pm 0.1^{\circ}\text{C}$
1000 Ω	-328 to 900	$\pm 0.7^{\circ}\text{F}$	-200 to 482	$\pm 0.4^{\circ}\text{C}$

Relays

Rating	2 or 4 SPDT (Form C) internal and/or 4 SPST (Form A) external; rated 3 A @ 30 VDC and 125/250 VAC resistive load; 1/14 HP (≈ 50 W) @ 125/250 VAC for inductive loads
Noise Suppression	Noise suppression is recommended for each relay contact switching inductive loads; see page 19 for details.
Deadband	0-100% of span, user programmable
High or Low Alarm	User may program any alarm for high or low trip point. Unused alarm LEDs and relays may be disabled (turn off).
Relay Operation	Automatic (non-latching) Latching (requires manual acknowledge) Sampling (based on time) Relay alternation control (2 to 4 relays) Off (disable unused relays and enable Interlock feature) Manual on/off control mode
Relay Reset	User selectable via front panel buttons or digital inputs <ol style="list-style-type: none"> Automatic reset only (non-latching), when the input passes the reset point. Automatic + manual reset at any time (non-latching) Manual reset only, at any time (latching) Manual reset only after alarm condition has cleared (L) <p><i>Note: Front panel button or digital input may be assigned to acknowledge relays programmed for manual reset.</i></p>
Time Delay	0 to 999.9 seconds, on & off relay time delays Programmable and independent for each relay
Fail-Safe Operation	Programmable and independent for each relay. <i>Note: Relay coil is energized in non-alarm condition.</i> <i>In case of power failure, relay will go to alarm state.</i>
Auto Initialization	When power is applied to the meter, relays will reflect the state of the input to the meter.

Isolated 4-20 mA Output

Output Source	PV (temperature), max, min, set points 1-4, Modbus PV input, or manual control mode		
Scaling Range	1.000 to 23.000 mA for any display range		
Calibration	Factory calibrated 0.0 to 2000.0 = 4-20 mA output		
Analog Out Programming	23.000 mA maximum for all parameters: Overrange, underrange, max, min, and break		
Accuracy	± 0.1% of span ± 0.004 mA		
Temperature Drift	0.4 µA/°C max from 0 to 65°C ambient, 0.8 µA/°C max from -20 to 0°C ambient <i>Note: Analog output drift is separate from input drift.</i>		
Power Supply For Analog Output Loop Or Other Uses	Terminals I+ & R: 24 VDC ± 10%. May be used to power the 4-20 mA output or other devices. Refer to Figure 6 on page 14 and Figure 17 on page 20. All models @ 25 mA max.		
External Loop Power Supply	35 VDC maximum		
Output Loop Resistance	Power supply	Minimum	Maximum
	24 VDC	10 Ω	700 Ω
	35 VDC (external)	100 Ω	1200 Ω

Serial Communications

Compatibility	EIA-485
Connectors	Removable screw terminal connector
Max Distance	3,937' (1,200 m) max
Status Indication	Separate LEDs for Power (P), Transmit (TX), and Receive (RX)
Slave Id	1 – 247 (Meter address)
Baud Rate	300 – 19,200 bps
Transmit Time Delay	Programmable between 0 and 199 ms
Data	8 bit (1 start bit, 1 or 2 stop bits)
Parity	Even, Odd, or None with 1 or 2 stop bits
Byte-To-Byte Timeout	0.01 to 2.54 sec
Turn Around Delay	Less than 2 ms (fixed)

Note: Refer to the PROVU® Modbus Register Tables located at www.predig.com for details.

Digital Inputs & Outputs

Channels	4 digital inputs & 4 digital outputs per module
Digital Input Logic High	3 to 5 VDC
Digital Input Logic Low	0 to 1.25 VDC
Digital Output Logic High	3.1 to 3.3 VDC
Digital Output Logic Low	0 to 0.4 VDC
Source Current	10 mA maximum output current
Sink Current	1.5 mA minimum input current
+5 V Terminal	To be used as pull-up for digital inputs only. Connect normally open pushbuttons across +5 V & DI 1-4.  DO NOT use +5 V terminal (pin 1) to power external devices. WARNING
Function Assignment	The on-board digital inputs (1-4) are designed to mimic the behavior of the front panel buttons (Menu, F1, F2, & F3). If you wish to change their behavior, reassign F1-F3 to the desired function, then change the corresponding digital input to match.

MeterView Pro

System Requirements	Microsoft® Windows® XP/Vista/7/8/10
Communications	USB 2.0 (Standard USB A to Micro USB B)
Configuration	Configure device settings one at a time

Product Ratings and Approvals;

FM	Enclosure: Type 4X; IP66 Class I, Division 1, Groups B, C, D Class II, Division 1, Groups E, F, G Class III, Division 1, T5/T6 Class I, Zone 1, AEx d, IIC Gb T5/T6 Zone 21, AEx tb IIIC T90°C; Ta -40°C to +65°C T6 Ta = -40°C to +60°C; T5 Ta = -40°C to +65°C Certificate Number: 3047283
CSA	Class I, Division 1, Groups B, C, D Class II, Division 1, Groups E, F, G Class III, Division 1 Class I Zone 1 Ex d IIC Zone 21 Ex tb IIIC T90°C -40°C < Tamb. < +60° C; Temperature Code T6 -40°C < Tamb. < +65° C; Temperature Code T5 Enclosure Type 4X & IP66 Certificate Number: 2531731
ATEX	 II 2 G D Ex d IIC T* Gb Ex tb IIIC T90°C Db IP68 Ta = -40°C to +*°C *T6 = -40°C to +60°C *T5 = -40°C to +65°C Certificate number: Sira 12ATEX1182
IECEX	Ex d IIC T* Gb Ex tb IIIC T90°C Db IP68 Ta = -40°C to +*°C *T6 = -40°C to +60°C *T5 = -40°C to +65°C Certificate Number: IECEX SIR 12.0073

Special Conditions for Safe Use:

Use suitably certified and dimensioned cable entry device and/or plug. The equipment shall be installed such that the supply cable is protected from mechanical damage. The cable shall not be subjected to tension or torque. If the cable is to be terminated within an explosive atmosphere, then appropriate protection of the free end of the cable shall be provided. Cable must be suitable for 90°C.

Year of Construction

This information is contained within the serial number with the first four digits representing the year and month in the YYMM format.

For European Community: The ProtEX-MAX must be installed in accordance with the ATEX directive 94/9/EC, and the product certificate Sira 12ATEX1182.

Compliance Information

Safety

UL & c-UL Listed	USA & Canada UL 508 Industrial Control Equipment
UL File Number	E160849
Front Panel	UL Type 4X, NEMA 4X, IP65; panel gasket provided
Low Voltage Directive	EN 61010-1:2010 Safety requirements for measurement, control, and laboratory use

Electromagnetic Compatibility

Emissions	EN 55022:2010 Class A ITE emissions requirements
Radiated Emissions	Class A
AC Mains Conducted Emissions	Class A
Immunity	EN 61326-1:2013 Measurement, control, and laboratory equipment EN 61000-6-2:2005 EMC heavy industrial generic immunity standard
RFI - Amplitude Modulated	80 -1000 MHz 10 V/m 80% AM (1 kHz) 1.4 - 2.0 GHz 3 V/m 80% AM (1 kHz) 2.0 - 2.7 GHz 1 V/m 80% AM (1 kHz)
Electrical Fast Transients	±2kV AC mains, ±1kV other
Electrostatic Discharge	±4kV contact, ±8kV air
RFI - Conducted	10V, 0.15-80 MHz, 1kHz 80% AM
AC Surge	±2kV Common, ±1kV Differential
Surge	1KV (CM)
Power-Frequency Magnetic Field	30 A/m 70%V for 0.5 period
Voltage Dips	40%V for 5 & 50 periods 70%V for 25 periods
Voltage Interruptions	<5%V for 250 periods

Note:

Testing was conducted on PD8-7000 meters installed through the covers of grounded metal enclosures with cable shields grounded at the point of entry representing installations designed to optimize EMC performance.

Declaration of Conformity available at www.predig.com

Safety Information



WARNINGS

- Read complete instructions prior to installation and operation of the instrument.
- Installation and service should be performed only by trained service personnel. Service requiring replacement of internal sub-components must be performed at the factory.
- Disconnect from supply before opening enclosure. Keep cover tight while circuits are alive. Conduit seals must be installed within 18" (450mm) of the enclosure or within 2" (50mm) for Zone installations.
- Verify that the operating atmosphere of the instrument is consistent with the appropriate hazardous locations certifications.
- If the instrument is installed in a high voltage environment and a fault or installation error occurs, high voltage may be present on any lead
- Read all product labels completely and follow all instructions and requirements listed on the labels for installation or service.

Installation

Install in accordance with applicable local and national regulations (e.g. NEC).

For Installation in USA: The ProtEX-MAX must be installed in accordance with the National Electrical Code (NEC) NFPA 70.

For Installation in Canada: The ProtEX-MAX must be installed in accordance with the Canadian Electrical Code CSA 22.1. All power supplies below 36 V and input circuits must be derived from a CSA Approved Class 2 source.

For European Community: The ProtEX-MAX must be installed in accordance with the ATEX directive 94/9/EC and the product certificate Sira 12ATEX1182.



WARNING

Disconnect from supply before opening enclosure. Keep cover tight while circuits are alive. Conduit seals must be installed within 18" (450mm) of the enclosure or within 2" (50mm) for Zone installations.

Wiring connectors are accessed by opening the enclosure. To access electrical connectors, remove the 2 captive screws and then remove the electronics module. Connectors are on the rear of the electronics module.

Unpacking

Remove the instrument from packing box. Inspect the packaging and contents for damage. Report damages, if any, to the carrier.

If any part is missing or the instrument malfunctions, please contact your supplier or the factory for assistance.

Pre-Installed Conduit/Stopping Plug

The PD8-6000 is supplied with two pre-installed conduit plugs for installations that do not require the use of all conduit entries. The conduit/stopping plugs include an internal 12mm hexagonal socket recess for removal. The pre-installed plugs and their installation are included in the hazardous area approvals for the PD8 Series enclosure.

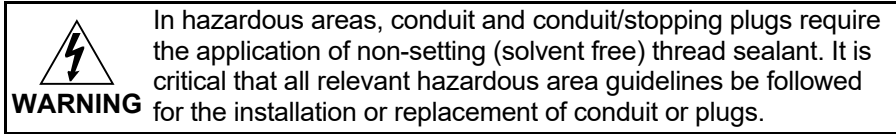

Mounting

The ProtEX-MAX has four slotted mounting flanges that should be used for pipe mounting or wall mounting. Refer to *Mounting Dimensions*, page 55 for details.

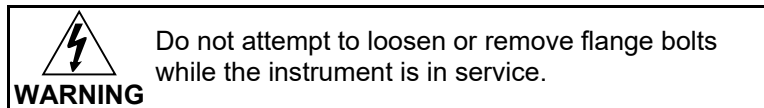

Cover Jam Screw

The cover jam screw should be properly installed once the instrument has been wired and tested in a safe environment. The cover jam screw is intended to prevent the removal of the instrument cover in a flameproof environment without the use of tools. Using a M2 hex wrench, turn the screw clockwise until the screw contacts the aluminum enclosure. Turn the screw an additional 1/4 to 1/2 turn to secure the cover. Caution: Excess torque may damage the threads and/or wrench.

Connections



WARNINGS

- **Static electricity can damage sensitive components.**
- **Observe safe handling precautions for static-sensitive components.**
- **Use proper grounding procedures/codes.**
- **If the instrument is installed in a high voltage environment and a fault or installation error occurs, high voltage may be present on any lead or terminal.**
- **Follow all fusing and wiring precautions requirements for the instrument integrated to the PD8 Series model number being connected.**

To access the connectors, remove the enclosure cover and unscrew the two captive screws that fasten the electronics module. Signal connections are made to de-pluggable connectors on the back of the electronics module.

Some connectors may be provided already connected. These connections are required for proper operation of the ProtEX-MAX and should not be removed unless instructed to by this manual.

Wires marked as being used for testing purposes should be removed.

Grounding connections are made to the two ground screws provided on the base – one internal and one external.

After all connections have been completed and verified, apply power to the unit.

Required & Factory Wired Connection

The ProtEX-MAX comes with a pre-wired connection. This connection is detailed below, and must be maintained in order for the instrument to function properly.



WARNING

Observe all safety regulations. Electrical wiring should be performed in accordance with all agency requirements and applicable national, state, and local codes to prevent damage to the meter and ensure personnel safety.

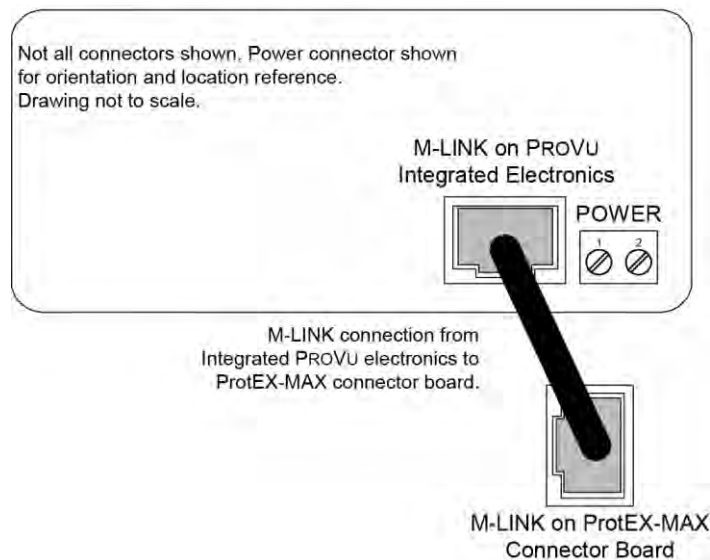

Figure 1: Integrated ProVu Required Connections

Connectors Labeling

The connectors' label, affixed to the meter, shows the location of all connectors available with requested configuration.

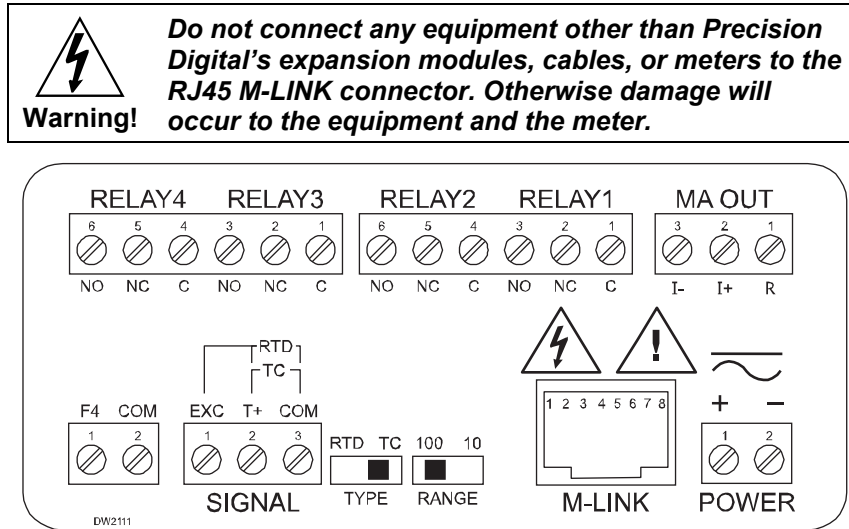
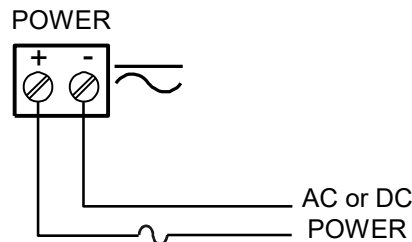

Figure 2. Connector Labeling for Fully Loaded PD8-7000

Power Connections

Power connections are made to a two-terminal connector labeled POWER on Figure 2. The meter will operate regardless of DC polarity connection. The + and - symbols are only a suggested wiring convention.



Required External Fuse:
5 A max, 250 V Slow Blow

Figure 3. Power Connections

Signal Connections

Signal connections are made to a three-terminal connector labeled SIGNAL on Figure 2.

Thermocouple and RTD Connections

The following figures show examples for thermocouple and RTD connections.

The TYPE selector switch must be set to the proper position for the meter to accept the selected RTD or TC input.

The RANGE selector switch is used to select 100-ohm platinum or 10-ohm copper RTD. The 1000-ohm platinum RTD input uses the same setting as the 100-ohm RTD.

The input type is selected using the *Setup* menu.

The selected thermocouple input must correspond to the thermocouple sensor and wire type used.

The meter accepts two, three, or four-wire RTDs. The three-wire RTD connection has built-in lead wire compensation.

Lead wire compensation for two-wire RTDs can be applied using the *Adjust* menu. See the Advanced Features Menu on page 40.

The four-wire RTD connection is similar to the three-wire. One of the leads of a four-wire RTD is not connected and may be clipped off.

The three-wire connection provides sufficient lead wire compensation to obtain accurate readings even with long leads.

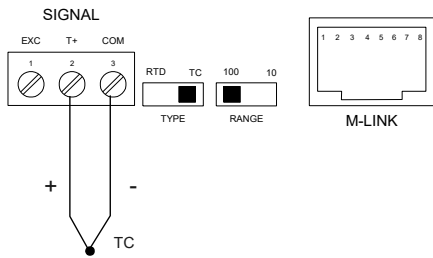

Figure 4. Thermocouple Input Connections

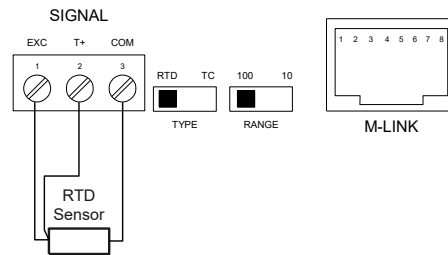

Figure 5. Three-Wire RTD Input Connections

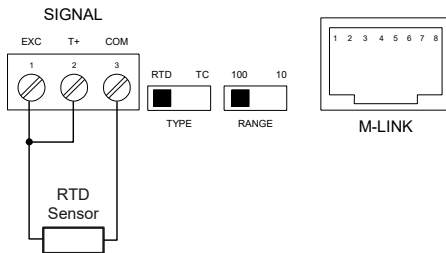

Figure 6. Two-Wire RTD Input Connections

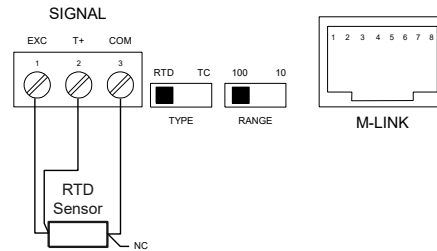

Figure 7. Four-Wire RTD Input Connections

Connections for Averaging RTD Sensors

To obtain the average temperature from 2 to 10 RTD sensors, connect all the sensors in parallel and select the number of sensors in the *RTD Total (rtdtot)* menu. See the Advanced Features Menu on page 40.

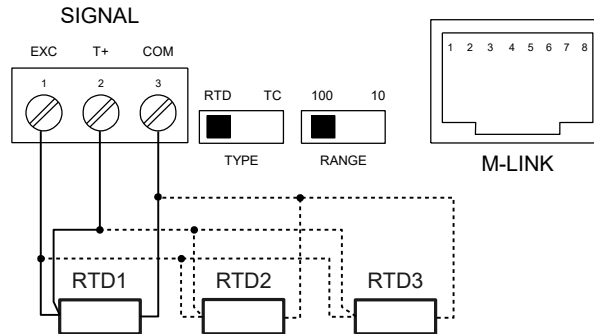

Figure 8. Average Temperature RTD Input Connections

Serial Communications Connections

The ProtEX-MAX has a 5 position terminal block for connecting RS-485 serial devices.

Figure 9 details the wiring connections from the ProtEX-MAX to an RS-485 serial converter (such as the PDA7485 or PDA8485) for a four-wire network.

ProtEX-MAX to RS-485 Serial Converter Connections	
RS-485 Serial Converter	ProtEX-MAX RS- 485 Connections
$\overline{\text{DI}}$	$\overline{\text{DI}}$
DO	DI
$\overline{\text{DI}}$	$\overline{\text{DO}}$
DI	DO

Figure 9: ProtEX-MAX Connections to a Serial Converter

The ProtEX-MAX has three diagnostic LEDs: a Power (P) LED to show when the module is powered properly, a Transmit Data (TX) LED to show when the module is being transmitted to by the PC side, and a Receive Data (RX) LED to show when the module is sending data to a receiving device.

The following diagrams detail how to connect the RS-485 serial communications from the ProtEX-MAX to a RS-485/RS-232 serial converter (PDA7485) in four wire and two wire configurations.

Three Wire Connections

In order to wire the 5 pins for use as a 3-wire half-duplex RS-485 connection, it is necessary to create a jumper connection between DI – DO and $\overline{\text{DI}}$ – $\overline{\text{DO}}$ as shown below.

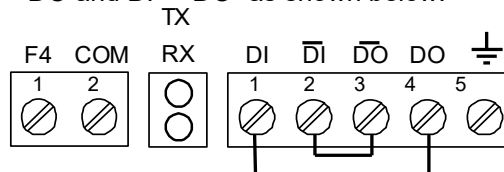

Figure 10. Three-Wire RS485 Connection

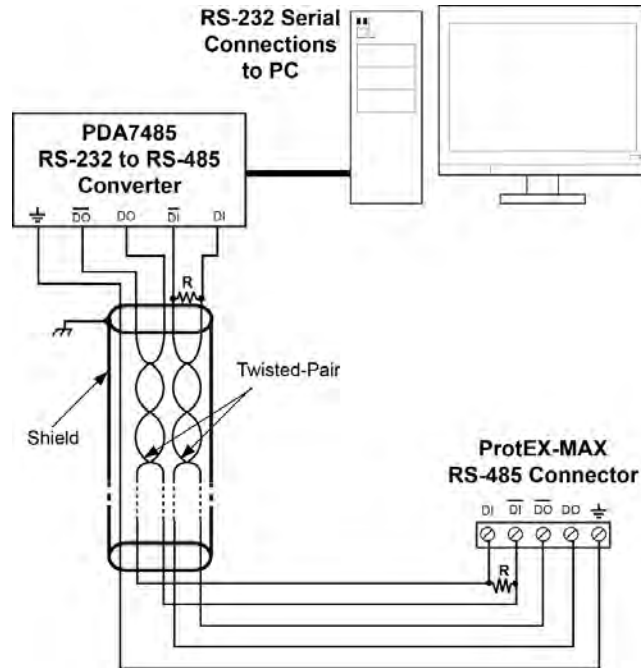



Figure 11: RS-485 Wiring

Notes:

1. Termination resistors are optional and values depend on the cable length and characteristic impedance. Consult the cable manufacturer for recommendations.
2. Refer to RS-232 to RS-485 Converter documentation for further details.
3. Use shielded cable, twisted-pairs plus ground. Connect ground shield only at one location.

 WARNING	<p>Observe all safety regulations. Electrical wiring should be performed in accordance with all agency requirements and applicable national, state, and local codes to prevent damage to the meter and ensure personnel safety.</p>
---	---

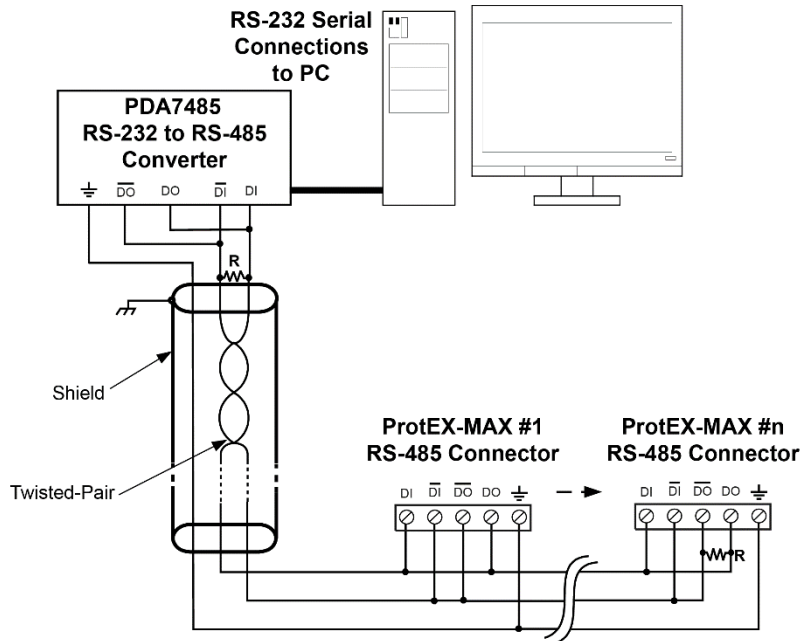



Figure 12: RS-485 Two-Wire Multi-Drop Wiring

Notes:

1. Termination resistors are optional and values depend on the cable length and characteristic impedance. Consult the cable manufacturer for recommendations.
2. Refer to RS-232 to RS-485 Converter documentation for further details.
3. Use shielded cable, twisted-pair plus ground. Connect ground shield only at one location.

 WARNING	Observe all safety regulations. Electrical wiring should be performed in accordance with all agency requirements and applicable national, state, and local codes to prevent damage to the meter and ensure personnel safety.
---	--

When using more than one instrument in a multi-drop or multi-point mode, each meter must be provided with its own unique address.

Using PROVu Serial Adapters

 NOTICE	PROVu expansion modules and serial adapters are not included in the hazardous area approvals of the ProtEX-MAX. The PDA1232 may be used only while the ProtEX-MAX is in a safe area, and will disable some features while installed.
--	--

PROVu expansion modules and serial adapters are not recommended for use with the ProtEX-MAX. It is recommended that any serial protocol conversion required on the RS-485 communications connection be performed using a PDA7485 RS-232 to RS-485 or PDA8485 USB to RS-485 serial converter located in a safe area.

Relay Connections

Relay connections are made to two six-terminal connectors labeled RELAY1 – RELAY4 on Figure 2. Each relay's C terminal is common only to the normally open (NO) and normally closed (NC) contacts of the corresponding relay. The relays' C terminals should not be confused with the COM (common) terminal of the INPUT SIGNAL connector.

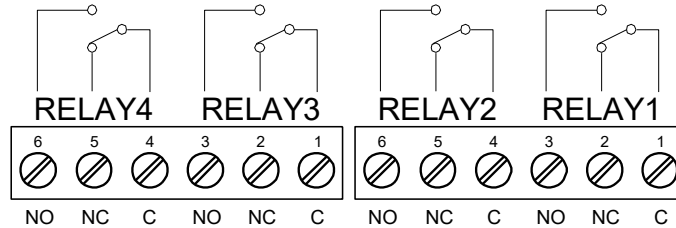

Figure 13. Relay Connections

Switching Inductive Loads

The use of suppressors (snubbers) is strongly recommended when switching inductive loads to prevent disrupting the microprocessor's operation. The suppressors also prolong the life of the relay contacts. Suppression can be obtained with resistor-capacitor (RC) networks assembled by the user or purchased as complete assemblies. Refer to the following circuits for RC network assembly and installation:

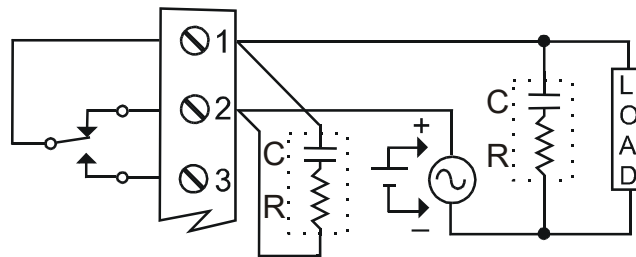

Figure 14. AC and DC Loads Protection

Choose R and C as follows:

R: 0.5 to 1 Ω for each volt across the contacts

C: 0.5 to 1 μF for each amp through closed contacts

Notes:

1. Use capacitors rated for 250 VAC.
2. RC networks may affect load release time of solenoid loads. Check to confirm proper operation.
3. Install the RC network at the meter's relay screw terminals. An RC network may also be installed across the load. Experiment for best results.

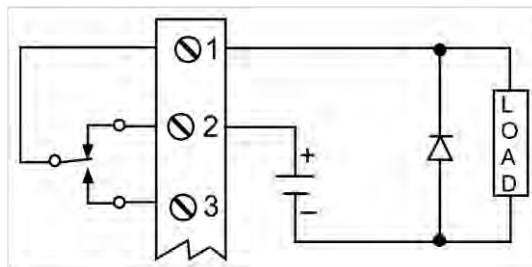

Use a diode with a reverse breakdown voltage two to three times the circuit voltage and forward current at least as large as the load current.

Figure 15. Low Voltage DC Loads Protection

RC Networks Available from Precision Digital

RC networks are available from Precision Digital and should be applied to each relay contact switching an inductive load. Part number: PDX6901.

Note: Relays are de-rated to 1/14th HP (50 watts) with an inductive load.

F4 Digital Input Connections

A digital input, F4, is standard on the meter. This digital input connected with a normally open closure across F4 and COM, or with an active low signal applied to F4.

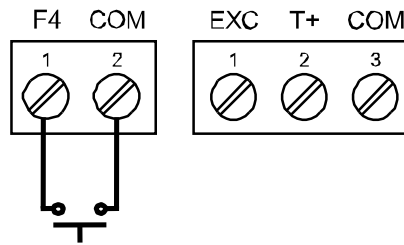

Figure 16. F4 Digital Input Connections

4-20 mA Output Connections

Connections for the 4-20 mA output are made to the connector terminals labeled MA OUT. The 4-20 mA output may be powered internally or from an external power supply.

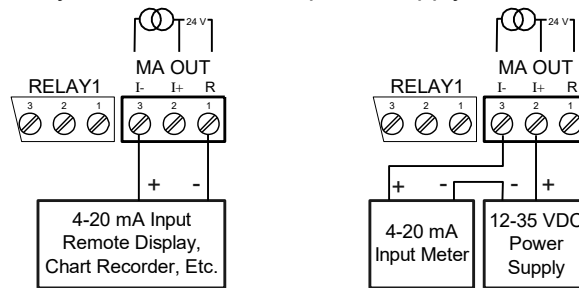

Figure 17. 4-20 mA Output Connections

Power Supply for Analog Output Loop or Other Uses

The internal 24 VDC power supply powering the analog output may be used to power other devices, if the analog output is not used. The I+ terminal is the +24 V and the R terminal is the return.

Interlock Relay Feature

As the name implies, the interlock relay feature reassigns one, or more, alarm/control relays for use as interlock relay(s). Interlock contact(s) are wired to digital input(s) and trigger the interlock relay. This feature is enabled by configuring the relay, and relative digital input(s) (see page 37). In one example, dry interlock contacts are connected in series to one digital input which will be used to force on (energize) the assigned interlock power relay when all interlock contacts are closed (safe). The interlock relay front panel LED flashes when locked out. The interlock relay would be wired in-series with the load (N/O contact). See below.

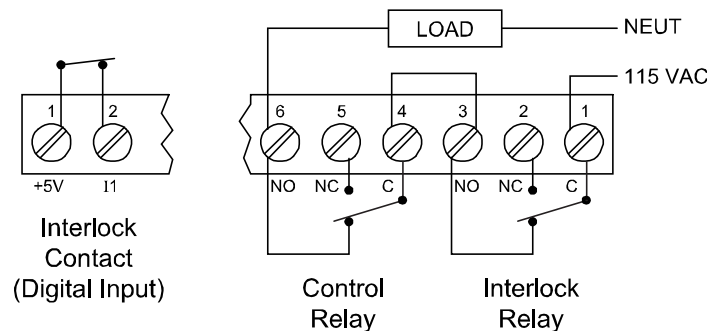

Figure 18. Interlock Connections

Digital I/O Connections

The ProtEX-MAX has a 10 position terminal block for connecting digital inputs and outputs.

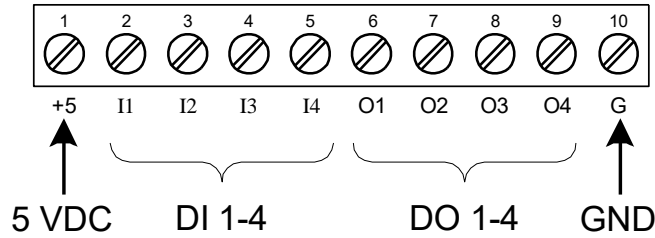



Figure 19: Digital I/O Connections

 NOTICE	<p>The onboard digital inputs (1-4) are configured at the factory to function identically to the front panel pushbuttons (Menu, F1, F2, & F3) in order to work with the SafeTouch buttons. Changing the programming of the digital inputs will affect the function of the SafeTouch buttons.</p> <p>If you wish to change the behavior of the digital inputs, re-assign F1-F3 to the desired function, then change the corresponding digital input to match.</p>
 WARNING	<p>Observe all safety regulations. Electrical wiring should be performed in accordance with all agency requirements and applicable national, state, and local codes to prevent damage to the meter and ensure personnel safety.</p>

External Switch Contacts

The ProtEX-MAX includes 4 digital inputs. These digital inputs are preconfigured at the factory to function as external contacts to duplicate the front button functions of the instrument. The factory configuration uses the following corresponding digital input terminals for external switch contacts.

Digital In-put Con-nection	Factory Default Func-tion
I1	MENU
I2	RIGHT arrow
I3	UP arrow
I4	ENTER arrow

See Digital Inputs & Outputs in the Specification on page 8 for details on the digital inputs.

 NOTICE	<p>The digital inputs are configured at the factory to function identically to the front panel pushbuttons in order to work with the SafeTouch buttons. Changing the programming of the digital inputs will affect the function of the SafeTouch buttons.</p>
--	---

Setup and Programming

The meter is factory calibrated prior to shipment to read temperature in degrees Fahrenheit. The calibration equipment is traceable to NIST standards.

Overview

There are two switches, located at the back of the meter, to set the input selection for TC or RTD and for 100-ohm platinum or 10-ohm copper. The 1000-ohm RTD input uses the same setting as the 100-ohm. Setup and programming is done through the front panel buttons.

After power and input signal connections have been completed and verified, apply power to the meter.

SafeTouch® Buttons

The ProtEX-MAX is equipped with four sensors that operate as through-glass buttons so that it can be programmed and operated without removing the cover (and exposing the electronics) in a hazardous area.

These buttons can be disabled for security by selecting DISABLE on the switch labeled NO-CONTACT BUTTONS located on the connector board.

To actuate a button, press one finger to the glass directly over the marked button area. Then retract finger more than three inches from the glass before pressing the next button. When the cover is removed, the four mechanical buttons located next to the sensors are used. The sensors are disabled when a mechanical button is pressed and will automatically be re-enabled after 60 seconds of inactivity.

The SafeTouch Buttons are designed to filter normal levels of ambient interference and to protect against false triggering, however, it is recommended that the SafeTouch Buttons be disabled (slide switch to LOCK) if there is an infrared interference source in line-of-sight to the display.

The SafeTouch Buttons are configured by default to duplicate the function of the front panel mechanical pushbuttons associated with the integrated meter. The symbols by each SafeTouch button correspond to a mechanical button as shown in the table on the next page.

SafeTouch Button Tips:

- To the extent possible, install the display facing away from sunlight, windows, reflective objects and any sources of infrared interference.
- Keep the glass window clean.
- Tighten the cover securely.
- Use a password to prevent tampering.











WARNING

Take caution when cleaning the window glass as it may result in unintentional SafeTouch button events. Only clean the ProtEX-MAX when the system is safely shut down, and inspect the ProtEX-MAX for proper configuration prior to system restart.

Front Buttons and Status LED Indicators



Button Symbol	Description	LED	Status
 or 	Menu	1-8	Alarm 1-8 indicator
 or 	Right arrow/F1	1-8-M	Flashing: Relay in manual control mode
 or 	Up arrow/F2	M	Manual control relays &/or analog output
 or 	Enter/F3	1-4	Flashing: Relay interlock switch open
<p><i>Note:</i> F4 is a digital input.</p>		<p><i>Note:</i> LEDs for relays in manual mode flash with the "M" LED every 10 seconds.</p>	

- Press the Menu button to enter or exit the Programming Mode at any time.
- Press the Right arrow button to move to the next digit during digit or decimal point programming.
- Press or hold the Up arrow button to scroll through the menus, move the decimal point or to increment the value of a digit.
- Press the Enter button to access a menu or to accept a setting.
- Press and hold the Menu button for three seconds to access the advanced features of the meter.

MeterView® Pro Software

The meter can also be programmed using the PC-based MeterView Pro software included with the meter. This software can be installed on any Microsoft® Windows® (XP/Vista/7/8/10) computer by connecting the meter's onboard USB. The meter is powered by the USB connection, so there is no need to wire anything prior to programming the meter, though USB is intended only for meter configuration.

MeterView Pro Installation

1. Connect one end of the provided USB cable to the internal electronics module and the other end to the computer. The computer will automatically install the driver software it needs to talk to the meter. **Only one meter may be connected at a time. Attaching multiple meters will cause a conflict with the meter software.**

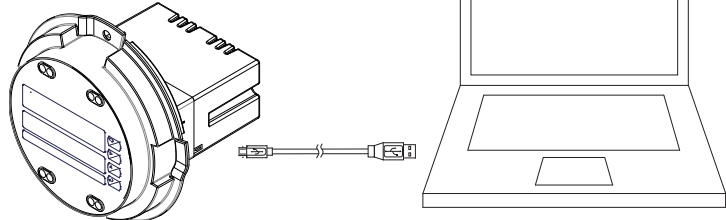

2. Once the driver is installed, an AutoPlay dialog should appear for the drive "MAINSTAL." Click "Open folder to view files." If the computer does not display an AutoPlay dialog for the drive "MAINSTAL," you should open My Computer and double-click on the drive labeled "MAINSTAL."
3. Double-click on the file named "MAStart." The program will open a few windows and install two programs on your computer. Simply follow the onscreen instructions until you see one of the dialogs below. If you receive a "User Account Control" warning, click "Yes."
4. If there is an update available, click the "Update" button to install the new version. Otherwise, click "Configure" to begin programming your meter.

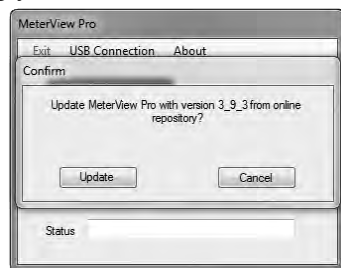

Note: If you decide to update your MeterView Pro software, once the installation has completed, you will be asked if you want to update the setup files located on the meter itself. This way, you will always have the most current version on the meter for future installs.



Warning!

Do not unplug the meter while the new installation files are being written to it. The meter will display μ E during the process and you will receive an onscreen notification once the process is complete.

Data logging for one meter at a time is available with MeterView Pro software. More advanced data acquisition may be accomplished by using any Modbus RTU compliant software. Additional information regarding configuration and monitoring of the meter using MeterView Pro software is available online. Go to www.predig.com/meterview-pro.

Display Functions & Messages

The meter displays various functions and messages during setup, programming, and operation. The following table shows the main menu functions and messages in the order they appear in the menu.

Display	Parameter	Action/Setting Description
SEtUP	Setup	Enter <i>Setup</i> menu
inPUt	Input	Enter <i>Input</i> selection menu
tC	TC	Set meter for thermocouple input J, K, T, E, R, S, B, N, C
rtd	RTD	Set meter for RTD input 100Pt, 1000Pt, 10Cu, 120Ni
A385	A385	Set meter for 0.00385 curve
A392	A392	Set meter for 0.00392 curve
F or C	F or C	Press Enter to select degrees F or C
unITS	Units	Select the display units/tags
dEc Pt	Decimal point	Set decimal point dddd, dddd.d, dddd°F, dddd.dF
dSPLY	Display	Enter the <i>Display</i> menu
Line 1	Line 1	Press Enter to assign the upper display parameter (default: PV - temperature)
Line 2	Line 2	Press Enter to assign the lower display parameter (default: engineering units)
d-IntY	Display intensity	Set display intensity level from 1 to 8
rELAY	Relay	Enter the <i>Relay</i> menu
Relay 1	Relay 1	Relay 1 setup
Action 1	Action 1	Set relay 1 action
Auto	Automatic	Set relay for automatic reset
Auto-manual	Auto-manual	Set relay for automatic & manual reset any time
LATCH	Latching	Set relay for latching operation

Display	Parameter	Action/Setting Description
Latching-cleared	Latching-cleared	Set relay for latching operation with manual reset only after alarm condition has cleared
ALtErn	Alternate	Set relay for alternation control
SAmPL	Sampling	Set relay for sampling operation
OFF	Off	Disable relay and front panel status LED (Select Off to enable Interlock feature)
Set 1	Set 1	Program set point 1
Reset 1	Reset 1	Program reset point 1
Relay 2	Relay 2	Relays 2-4 setup
Fail-safe	Fail-safe	Enter <i>Fail-safe</i> menu
Fail-safe 1	Fail-safe 1	Set relay 1 fail-safe operation
On	On	Enable fail-safe operation
Off	Off	Disable fail-safe operation
Fail-safe 2	Fail-safe 2	Set relays 2-4 fail-safe operation
Delay	Delay	Enter relay <i>Time Delay</i> menu
Delay 1	Delay 1	Enter relay 1 time delay setup
On 1	On 1	Set relay 1 On time delay
Off 1	Off 1	Set relay 1 Off time delay
Delay 2	Delay 2	Enter relays 2-4 time delay setup
Break	Break	Set relay condition if input break detected
Ignore	Ignore	Ignore input break condition (Processed as an upscale condition)
On	On	Relay goes to alarm condition when input break is detected

Display	Parameter	Action/Setting Description
OFF	Off	Relay goes to non-alarm condition when input break is detected
Rout	Analog output	Enter the Analog output scaling menu
dis 1	Display 1	Program display 1 value
Out 1	Output 1	Program output 1 value (e.g. 4.000 mA)
dis 2	Display 2	Program display 2 value
Out 2	Output 2	Program output 2 value (e.g. 20.000 mA)
rESEt	Reset	Press Enter to access the Reset menu
rSt H	Reset high	Press Enter to reset max display
rSt Lo	Reset low	Press Enter to reset min display
rSt Hl	Reset hi/low	Press Enter to reset max & min displays
ContRL	Control	Enter Control menu

Display	Parameter	Action/Setting Description
Ruto	Automatic	Press Enter to set meter for auto operation
Man	Manual	Press Enter to manually control relays or analog output operation
PR55	Password	Enter the Password menu
PR55 1	Password 1	Set or enter Password 1
PR55 2	Password 2	Set or enter Password 2
PR55 3	Password 3	Set or enter Password 3
unLoc	Unlocked	Program password to lock meter
Locd	Locked	Enter password to unlock meter
99999 -9999	Flashing display	Overrange condition Underrange condition
OPEn	Open	Open sensor indication

Main Menu

The main menu consists of the most commonly used functions: *Setup, Reset, Control, and Password.*

- Press Menu button to enter Programming Mode then press the Up arrow button to scroll main menu.
- Press Menu, at any time, to exit and return to Run Mode. Changes made to settings prior to pressing Enter are not saved.
- Changes to the settings are saved to memory only after pressing Enter/F3.
- The display moves to the next menu every time a setting is accepted by pressing Enter/F3.

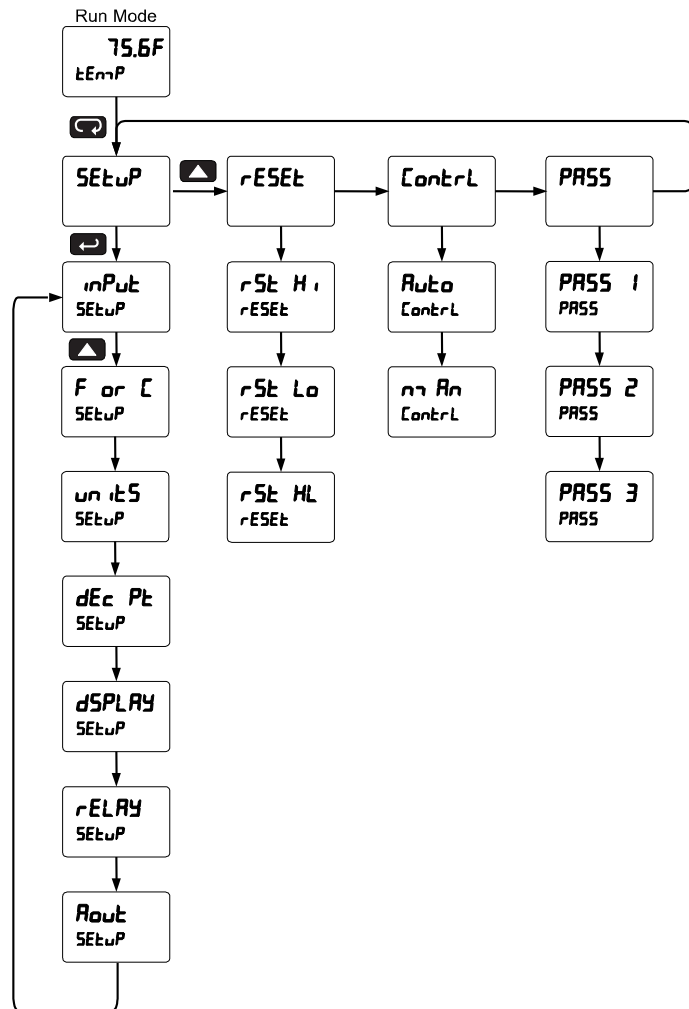

Setting Numeric Values

The numeric values are set using the Right and Up arrow buttons. Press Right arrow to select next digit and Up arrow to increment digit value.

The digit being changed is displayed brighter than the rest.

Press and hold up arrow to auto-increment the display value.

Press the Enter button, at any time, to accept a setting or Menu button to exit without saving changes.

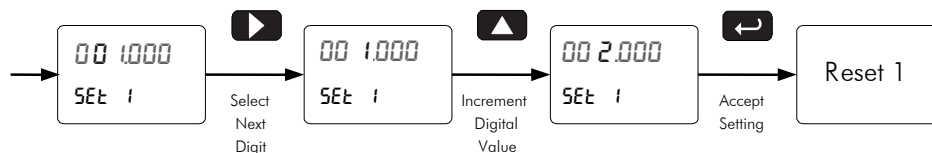

Setting Up the Meter (SEtUP)

It is **very important** to read the following information, before proceeding to program the meter:

- The meter is factory calibrated prior to shipment to read temperature in degrees Fahrenheit. The calibration equipment is traceable to NIST standards.
- There is no need to calibrate the meter, simply select the input type, °F or °C, and decimal point.

The *Setup* menu is used to select:

1. Input type the meter will accept
2. Degrees F or C
3. Select the display units/tags
4. Decimal point position and F or C indication
5. Display parameter and intensity
6. Relay operation
7. 4-20 mA analog output scaling

Press the Enter button to access any menu or press Up arrow button to scroll through choices. Press the Menu button to exit at any time.

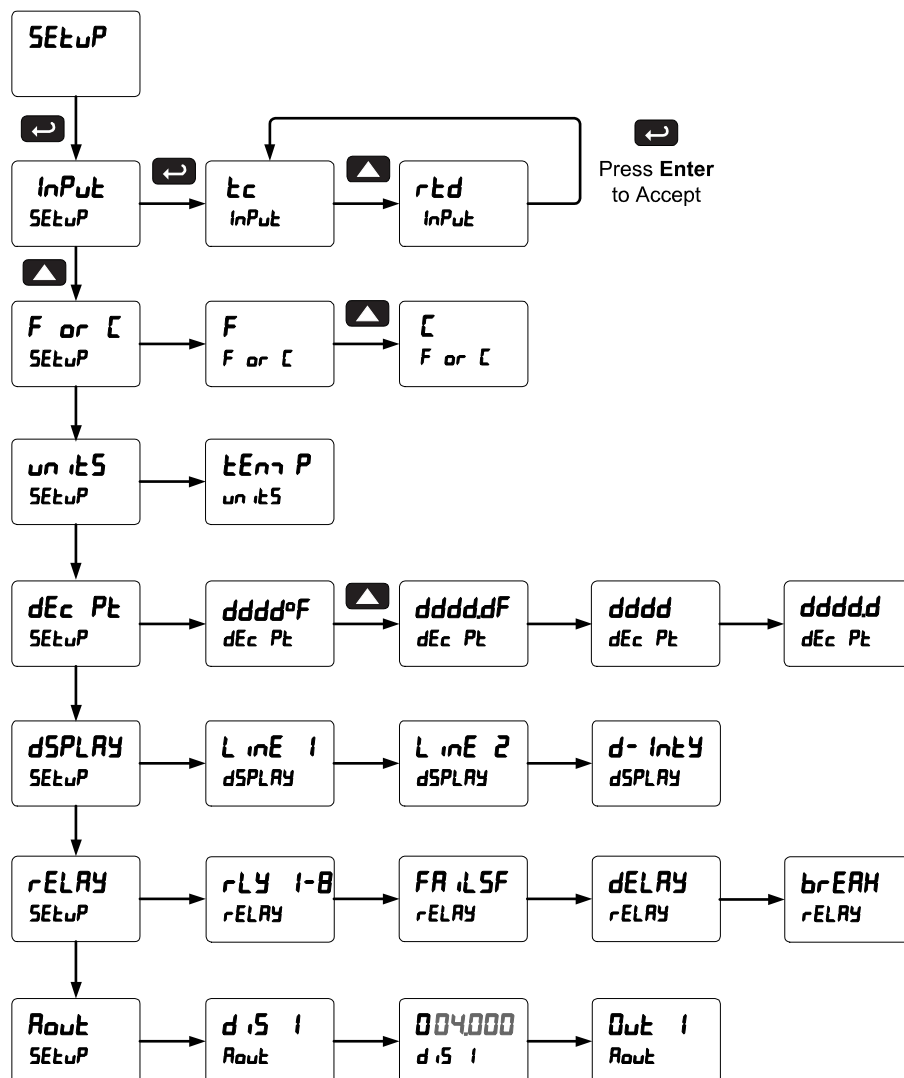

Setting the Input Signal (*inPUt*)

Enter the *Input* menu to set up the meter to accept thermocouple (*tC*) or RTD (*rTd*) inputs. The Type selector switch, located at the rear of the meter, must be set accordingly.

The thermocouple input is capable of accepting various types of thermocouples.

The RTD input is capable of accepting various types of RTD sensors. After selecting 100 Pt or 1000Pt, it is necessary to select either A385 (0.00385) or A392 (0.00392) coefficient.

Selecting the Temperature Scale (*F* or *C*)

The meter can display the temperature in degrees Fahrenheit or Celsius.

Setting the Decimal Point (*dEc Pt*)

The temperature may be displayed with one decimal or with no decimal point. The temperature scale can also be displayed with the reading. The degree symbol is available only with no decimal point selected.

Pressing the Up arrow scrolls the decimal point and temperature format selections.

Setting the Display Parameter & Intensity (*dSPLaY*)

Display line 1 (*L inE 1*) can be programmed to display:

1. Process value
2. Relay set points
3. Max & min values
4. Modbus input
5. Display reading and units

Display line 2 (*L inE 2*) can be programmed to display:

1. Process value
2. Relay set points
3. Max & min values
4. Engineering units or custom legends
5. Modbus input
6. Off (no display)
7. Display reading and units

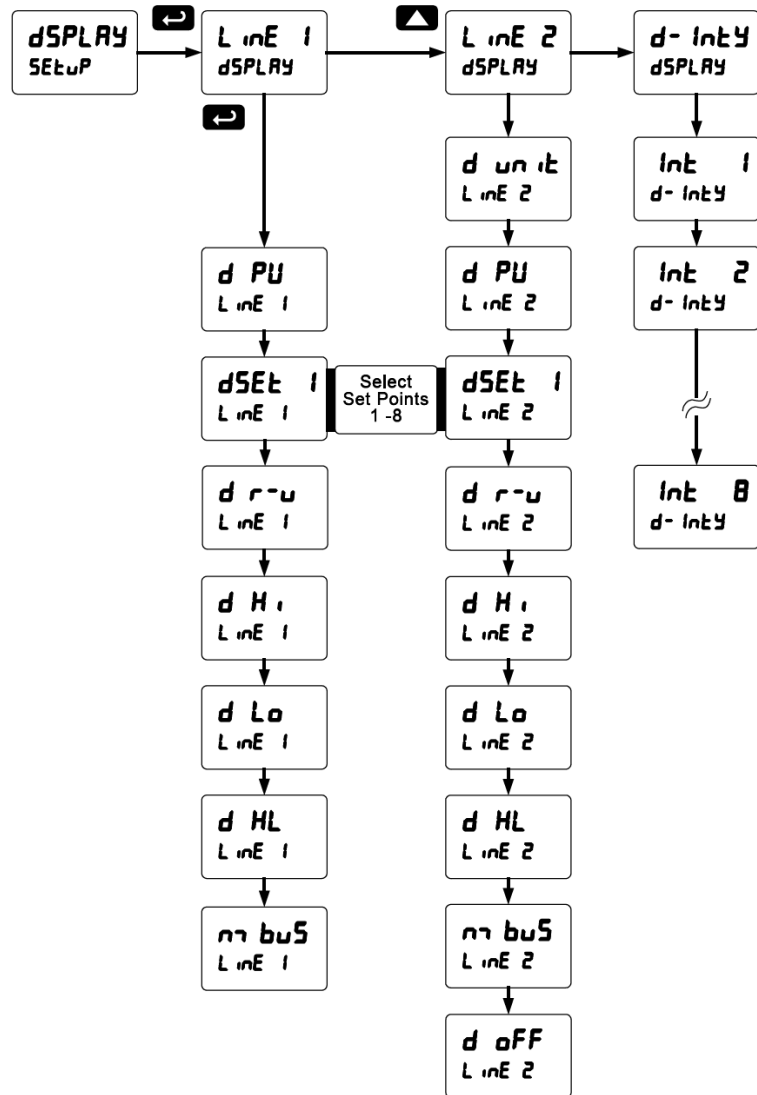

Display Intensity: The meter has eight display intensity levels to give the best performance under various lighting conditions. Select intensity 8 for outdoor applications. The default intensity is 8.

Press the Up arrow to change selection, press Enter to accept setting, and press Menu to exit programming

After setting up the input and display, press the Menu button to exit programming and skip the rest of the setup menu. Press the Menu button again and the Up arrow to reach the *Setup* menu again and complete the setup of the meter.

Setting the Input Units or Custom Tags (uNt5)

Enter the input unit or custom tag that will be displayed if alternating rate, total, or grand total and units is selected in the uNt5 menu, or d uNt5 is selected as the Lower display parameter. See the flow chart on page 29 to access the display menu to show the unit or tag on the Lower display. The engineering units or custom legends can be set using the following 7-segment character set:

Display	Character	Display	Character	Display	Character	Display	Character
0	0	C	C	K	K	v	V
1	1	c	c	L	L	w	w
2	2	d	d	m	m	X	X
3	3	E	E	n	n	Y	Y
4	4	F	F	O	O	Z	Z
5	5	G	G	o	o	-	-
6	6	g	g	P	P	/	/
7	7	H	H	q	q	[]
8	8	h	h	r	r]	[
9	9	i	i	S	S	=	=
A	A	l	l	t	t	°	Degree(<)
b	b	J	J	u	u		Space

Notes:

Degree symbol represented by (<) if programming with MeterView® Pro.

The letters “m” and “w” use two 7-segment LEDs each; when selected the characters to the right are shifted one position.

Press and hold up arrow to auto-scroll the characters in the display.

Setting the Relay Operation (rELAY)

This menu is used to set up the operation of the relays.

1. Relay action
 - a. Automatic reset only (non-latching)
 - b. Automatic + manual reset at any time (non-latching)
 - c. Latching (manual reset only)
 - d. Latching with Clear (manual reset only after alarm condition has cleared)
 - e. Relay alternation control (automatic reset only)
 - f. Sampling (the relay is activated for a user-specified time)
 - g. Off (relay disabled and Interlock feature enabled)
2. Set point
3. Reset point
4. Fail-safe operation
 - a. On (enabled)
 - b. Off (disabled)
5. Time delay
 - a. On delay (0-999.9 seconds)
 - b. Off delay (0-999.9 seconds)
6. Relay action for loss (break) of input (ignore, on, off)



Caution! During setup, the relays do not follow the input and they will remain in the state found prior to entering the Relay menu.

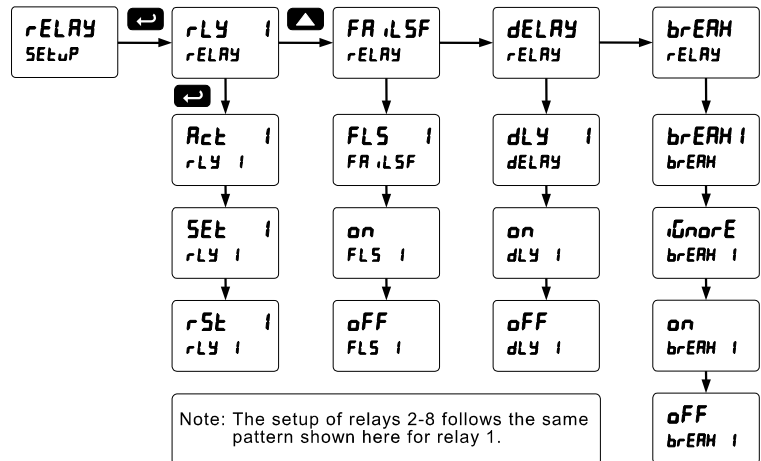

Setting the Relay Action

Operation of the relays is programmed in the *Action* menu. The relays may be set up for any of the following modes of operation:

1. Automatic reset (non-latching)
2. Automatic + manual reset at any time (non-latching)
3. Latching (manual reset only, at any time)
4. Latching with Clear (manual reset only after alarm condition has cleared)
5. Relay alternation control (automatic reset only)
6. Sampling (the relay is activated for a user-specified time)
7. Off (relay disabled and Interlock feature enabled)

The following graphic shows relay 1 action setup; relay 2-4 are set up in a similar fashion.

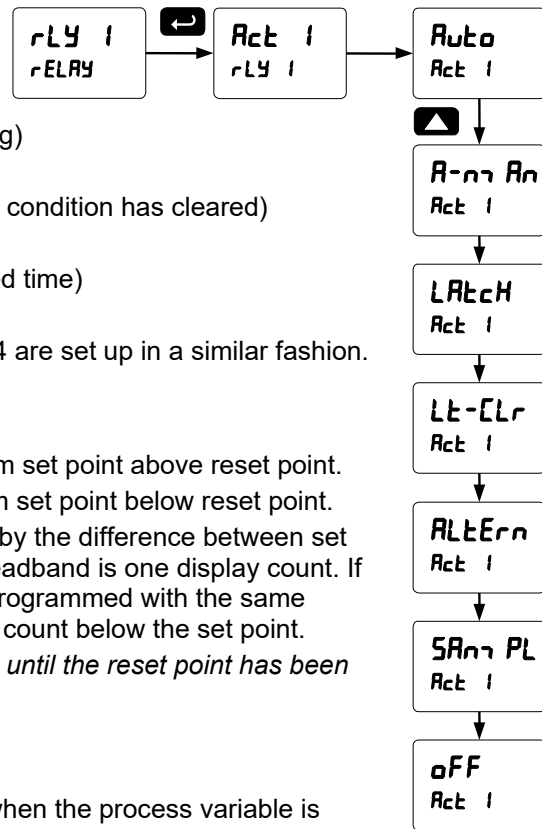

Programming Set and Reset Points

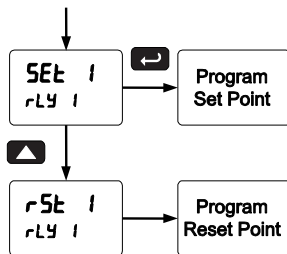

High alarm indication: program set point above reset point.
 Low alarm indication: program set point below reset point.
 The deadband is determined by the difference between set and reset points. Minimum deadband is one display count. If the set and reset points are programmed with the same value, the relay will reset one count below the set point.
Note: Changes are not saved until the reset point has been accepted.

Setting Fail-Safe Operation

In fail-safe mode of operation, the relay coil is energized when the process variable is within safe limits and the relay coil is de-energized when the alarm condition exists. The fail-safe operation is set independently for each relay. Select **on** to enable or select **oFF** to disable fail-safe operation.

Programming Time Delay

The *On* and *Off* time delays may be programmed for each relay between 0 and 999.9 seconds. The relays will transfer only after the condition has been maintained for the corresponding time delay.

The *On* time delay is associated with the set point.

The *Off* time delay is associated with the reset point.

Relay Action for Loss of Input (Input Break)

Each relay may be programmed to go to one of the following conditions when the meter detects the loss of the input signal:

1. Turn *On* (Go to alarm condition)
2. Turn *Off* (Go to non-alarm condition)
3. Ignore (Processed as an upscale condition)

Relay and Alarm Operation Diagrams

The following graphs illustrate the operation of the relays, status LEDs, and ACK button.

High Alarm Operation (Set > Reset)

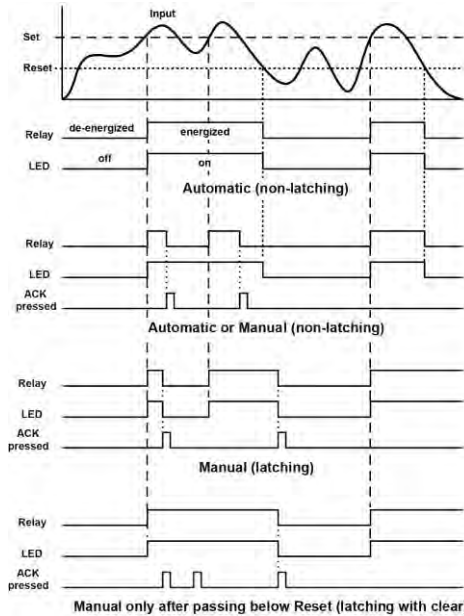

For Manual reset mode, ACK can be pressed anytime to turn "off" relay. To detect a new alarm condition, the signal must go below the set point, and then go above it.

Low Alarm Operation (Set < Reset)

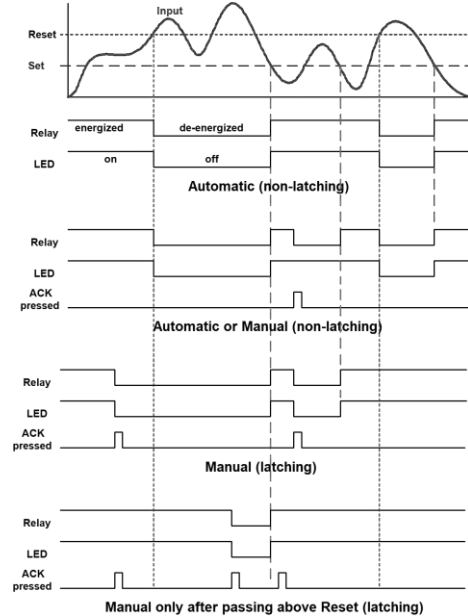

For Manual reset mode, ACK can be pressed anytime to turn "off" relay. For relay to turn back "on", signal must go above set point and then go below it.

High Alarm with Fail-Safe Operation (Set > Reset)

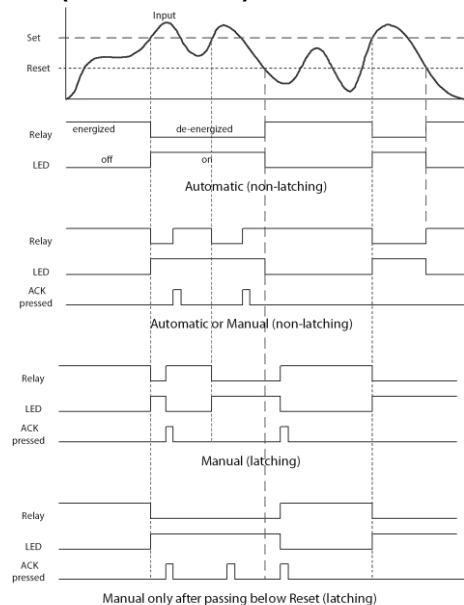

Note: Relay coil is energized in non-alarm condition. In case of power failure, relay will go to alarm state.

Low Alarm with Fail-Safe Operation (Set < Reset)

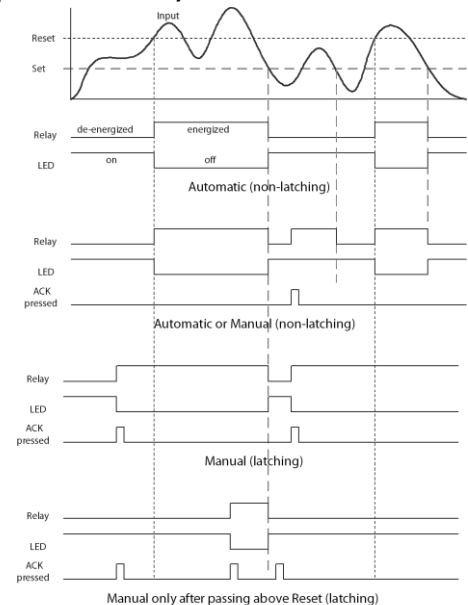

Note: Relay coil is energized in non-alarm condition. In case of power failure, relay will go to alarm state.

Pump Alternation Control Operation

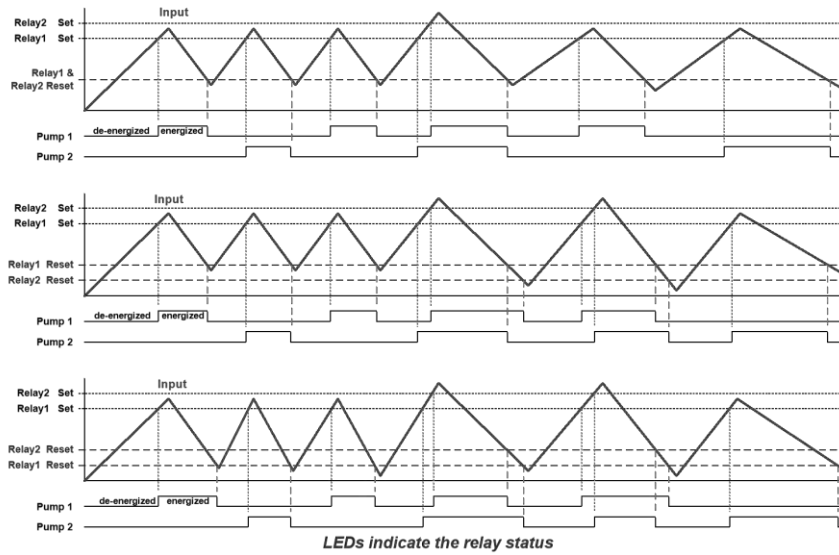

Relay Sampling Operation

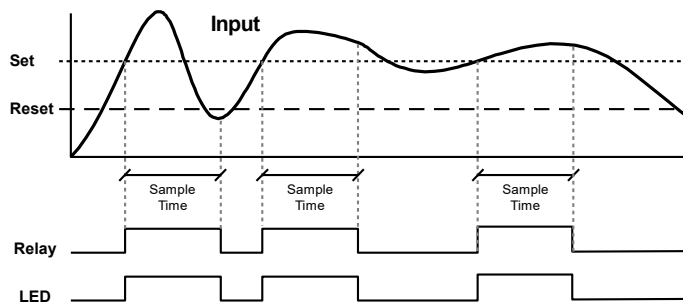

When the signal crosses the set point, the relay trips and the sample time starts. After the sample time has elapsed, the relay resets. The cycle repeats every time the set point is crossed, going up for high alarms and going down for low alarms.

The sample time can be programmed between 0.1 and 5999.9 seconds.

Signal Loss or Input Break Relay Operation

The following graph shows the input break relay operation for a high alarm relay.

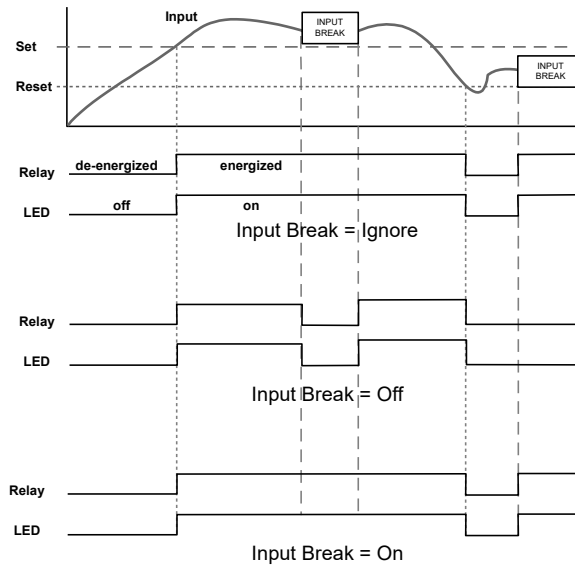

When the meter detects a break in the input, the relay will go to one of the following selected actions:

1. Turn *On* (Go to alarm condition)
2. Turn *Off* (Go to non-alarm condition)
3. Ignore (Processed as an upscale condition)

Time Delay Operation

The following graphs show the operation of the time delay function.

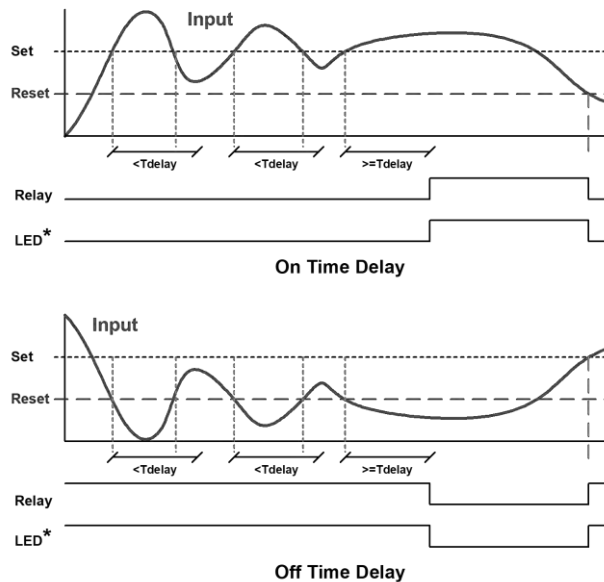

When the signal crosses the set point, the *On* time delay timer starts and the relay trips when the time delay has elapsed. If the signal drops below the set point (high alarm) before the time delay has elapsed, the *On* time delay timer resets and the relay does not change state. The same principle applies to the *Off* time delay.

Note: If "Automatic or Manual (A-n-A)" reset mode is selected, the LED follows the reset point and not the relay state when the relay is acknowledged.

Relay Operation Details

Overview

The relay capabilities of the meter expand its usefulness beyond simple indication to provide users with alarm and control functions. These capabilities include front panel alarm status LEDs as well as either 2 or 4 optional internal relays. Typical applications include high or low temperature alarms, control applications such as simple on/off temperature control. There are four basic ways the relays can be used:

1. High or Low Alarms with Latching or Non-Latching Relays
2. Simple On/Off Control with 100% Adjustable Deadband
3. Sampling (Based on Time)
4. Relay Alternation Control

Relays Auto Initialization

When power is applied to the meter, the front panel LEDs and alarm relays will reflect the state of the input to the meter. The following table indicates how the alarm LEDs and relays will react on power-up based on the set and reset points:

Alarm #	HI or LO Alarm	Set Point	Reset Point	Power-Up Reading	Relay & LED
1	HI	1000	500	499	Off
2	LO	700	900	499	On
3	LO	250	400	499	Off
4	HI	450	200	499	On

Fail-Safe Operation

The following table indicates how the relays behave based on the fail-safe selection for each relay:

Note: NO = Normally Open, NC = Normally Closed. This refers to the condition of the relay contacts when the power to the meter is off.

Fail-Safe Selection	Non-Alarm State		Alarm State		Power Failure
	NO	NC	NO	NC	
Off	Open	Closed	Closed	Open	Relays go to non-alarm state
On	Closed	Open	Open	Closed	Relays go to alarm state

Front Panel LEDs

The LEDs on the front panel provide status indication for the following:

The meter is supplied with four alarm points that include front panel LEDs to indicate alarm conditions. This standard feature is particularly useful for alarm applications that require visual-only indication. The LEDs are controlled by the set and reset points programmed by the user. When the display reaches a set point for a high or low alarm, the corresponding alarm LED will turn on. When the display returns to the reset point the LED will go off. The front panel LEDs respond differently for latching and non-latching relays.

LED	Status
1	Alarm 1
2	Alarm 2
3	Alarm 3
4	Alarm 4

LED	Status
5	Alarm 5
6	Alarm 6
7	Alarm 7
8	Alarm 8

For non-latching relays, the LED is always off during normal condition and always on during alarm condition, regardless of the state of the relay (e.g. Relay acknowledged after alarm condition).

For latching relays, the alarm LEDs reflect the status of the relays, regardless of the alarm condition. The following tables illustrate how the alarm LEDs function in relation to the relays and the acknowledge button (Default: F3 key assigned to ACK).

Latching and Non-Latching Relay Operation

The relays can be set up for latching (manual reset) or non-latching (automatic reset) operation.

The On and Off terminology does not refer to the status of the relay's coil, which depends on the fail-safe mode selected.

Relay terminology for following tables	
Terminology	Relay Condition
On	Alarm (Tripped)
Off	Normal (Reset)
Ack	Acknowledged



Warning! *In latching relay mode, latched relays will reset (unlatch) when power is cycled.*

Non-Latching Relay (Rύεο)

In this application, the meter is set up for automatic reset (non-latching relay). Acknowledging the alarm while it is still present has no effect on either the LED or the relay. When the alarm finally goes away, the relay automatically resets and the LED also goes off.

Automatic reset only		
Condition	LED	Relay
Normal	Off	Off
Alarm	On	On
Ack (No effect)	On	On
Normal	Off	Off

Non-Latching Relay (R-οηRη)

In this application, the meter is set up for automatic and manual reset at any time (non-latching relay). The LED and the relay automatically reset when the meter returns to the normal condition.

The next time an alarm occurs, the operator acknowledges the alarm manually while the alarm condition still exists. This causes the relay to reset, but the LED stays on until the meter returns to the normal condition.

Automatic + manual reset at any time		
Condition	LED	Relay
Normal	Off	Off
Alarm	On	On
Normal	Off	Off
Next Alarm	On	On
Ack	On	Off
Normal	Off	Off

Latching Relay (L RύεH)

In this application, the meter is set up for manual reset at any time. Acknowledging the alarm even if the alarm condition is still present resets the relay and turns off the LED.

Manual reset any time		
Condition	LED	Relay
Normal	Off	Off
Alarm	On	On
Ack	Off	Off

Latching Relay (L L - [Lr)

In this application, the meter is set up for manual reset only after the signal passes the reset point (alarm condition has cleared). Acknowledging the alarm while it is still present has no effect on either the LED or the relay. When the alarm is acknowledged after it returns to the normal state, the LED and the relay go off. Notice that the LED remains on, even after the meter returns to the normal condition. This is because, for latching relays, the alarm LED reflects the status of the relay, regardless of the alarm condition.

Manual reset only after alarm condition has cleared		
Condition	LED	Relay
Normal	Off	Off
Alarm	On	On
Ack (No effect)	On	On
Normal	On	On
Ack	Off	Off

Acknowledging Relays

There are two ways to acknowledge relays programmed for manual reset:

1. Via the programmable front panel function keys F1-F3 (Default: F3 assigned to ACK).
2. Remotely via a normally open pushbutton wired across one of the digital inputs and the +5 V terminals on the digital I/O modules, or using the F4 digital input, which is triggered with a contact closure to COM, or with an active low signal (see page 20).

When the ACK button or the assigned digital input is closed, all relays programmed for manual reset are acknowledged.

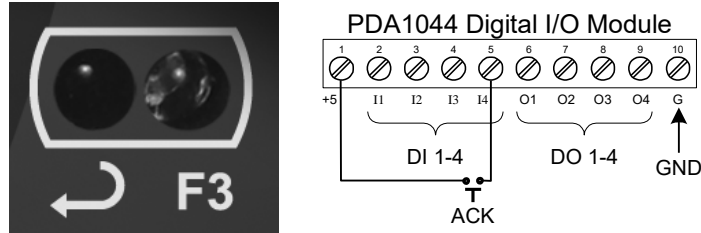
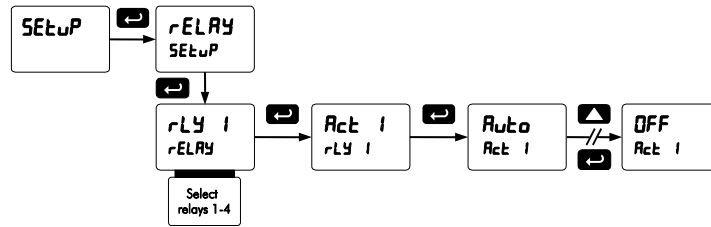

Figure 20. Acknowledge Relays w/Function Key or Digital Input

Setting Up the Interlock Relay (Force On) Feature

Relays 1-4 can be set up as interlock relays. To set up the relays for the interlock feature:

1. Access the *Setup – Relay – Action* menu and set the action to off.



2. In the Advanced features – *User* menu program any of the digital inputs to *Force On* any of the internal relays (1-4).

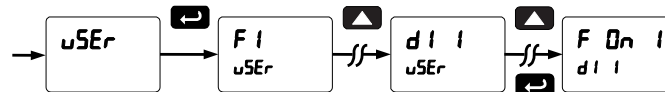

3. Connect a switch or dry contact between the +5V terminal and the corresponding digital input (DI-1 to DI-4) terminal.

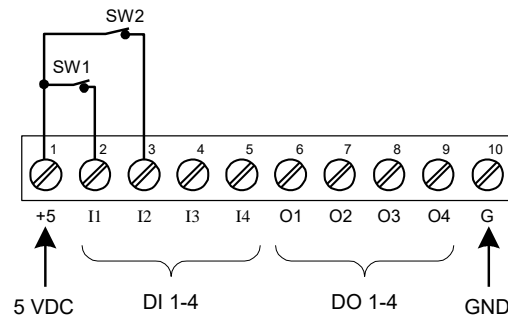

Interlock Relay Operation

Relays 1 & 2 are energized when SW1 & SW2 switches are closed and the front panel LEDs are off. If the contact to the digital input is opened, the corresponding front panel LED flashes indicating this condition. The processes being controlled by the interlock relay stop and will re-start only after the interlock relay is activated by the digital inputs.

Scaling the 4-20 mA Analog Output (Rout)

The 4-20 mA analog output can be scaled to provide a 4-20 mA signal for any display range selected. No equipment is needed to scale the analog output; simply program the display values to the corresponding mA output signal.

The *Analog Output* menu is used to program the 4-20 mA output based on display values.

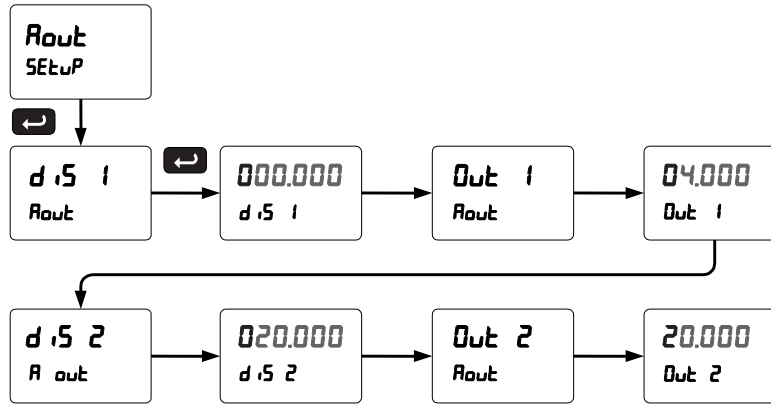

Note: During the analog output scaling, the display value is always indicated with a decimal point regardless of the decimal point selection for the temperature display.

For instructions on how to program numeric values see *Setting Numeric Values*, page 27.

Reset Menu (rESEt)

The *Reset* menu is used to reset the maximum or minimum reading (peak or valley) reached by the process; both may be reset at the same time by selecting “reset high & low” (r5t HL).

Control Menu (Contrl)

The *Control* menu is used to control the 4-20 mA analog output and the relays manually, ignoring the input. Each relay and analog output can be programmed independently for manual control. Selecting automatic control sets all relays and analog output for automatic operation.

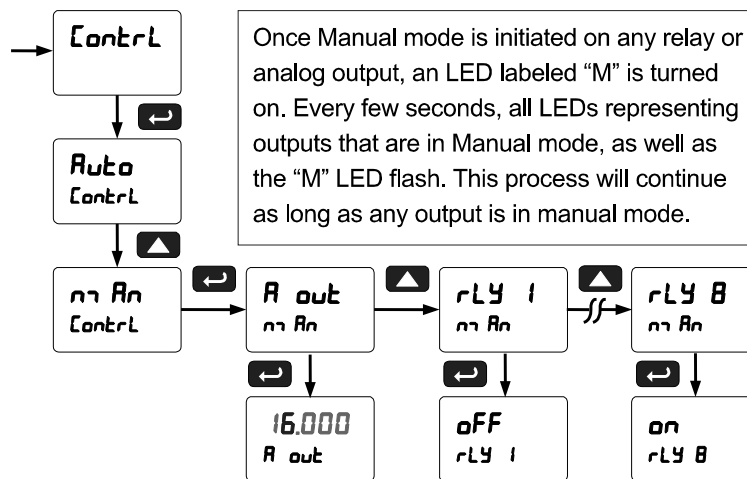

Setting Up the Password (PASS)

The *Password* menu is used for programming three levels of security to prevent unauthorized changes to the programmed parameter settings.

Pass 1: Allows use of function keys and digital inputs
 Pass 2: Allows use of function keys, digital inputs and editing set/reset points
 Pass 3: Restricts all programming, function keys, and digital inputs.

Protecting or Locking the Meter

Enter the *Password* menu and program a six-digit password.

For instructions on how to program numeric values see *Setting Numeric Values*, page 27.

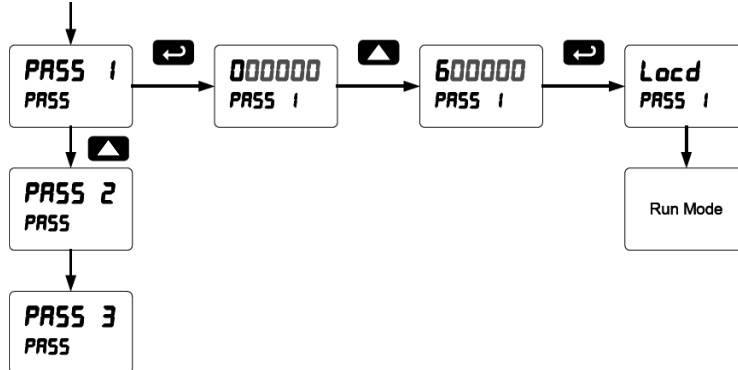

Making Changes to a Password Protected Meter

If the meter is password protected, the meter will display the message *Locd* (*Locked*) when the Menu button is pressed. Press the Enter button while the message is being displayed and enter the correct password to gain access to the menu.

Note: After exiting the programming mode, the meter returns to its password protected condition.

Disabling Password Protection

To disable the password protection, access the *Password* menu and enter the correct password twice, as shown below. The meter is now unprotected until a new password is entered.

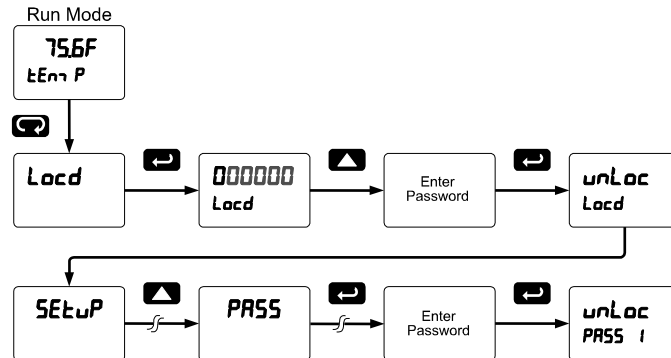

If the correct six-digit password is entered, the meter displays the message *unLoc* (*unlocked*) and the protection is disabled until a new password is programmed.

If the password entered is incorrect, the meter displays the message *Locd* (*Locked*) for about two seconds, and then it returns to Run Mode. To try again, press Enter while the *Locked* message is displayed.

Did you forget the password?

The password may be disabled by entering a master password once. If you are authorized to make changes, enter the master password 508655 to unlock the meter.

Advanced Features Menu

To simplify the setup process, functions not needed for most applications are located in the *Advanced Features* menu.

Press and hold the Menu button for three seconds to access the advanced features of the meter.

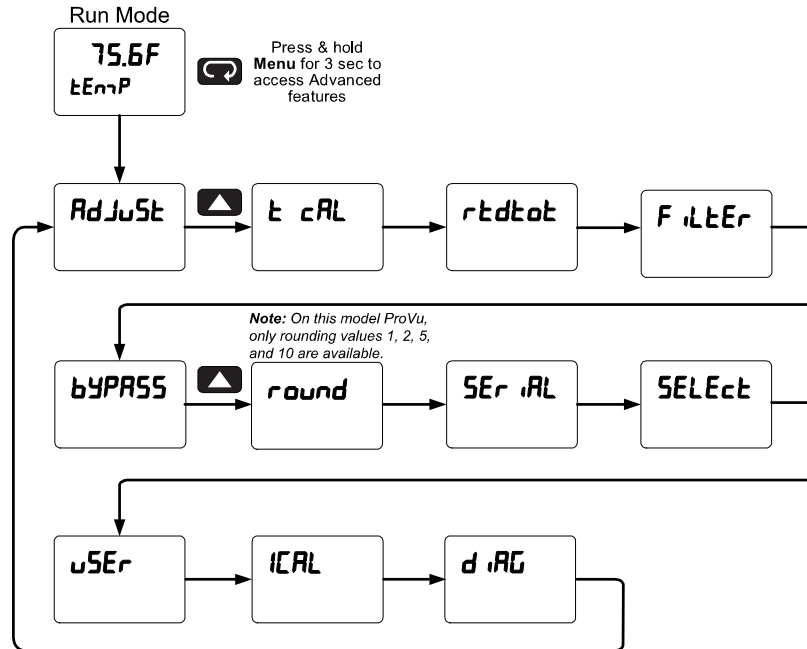

Advanced Features Menu & Display Messages

The following table shows the functions and messages of the *Advanced Features* menu in the order they appear in the menu.

Display	Parameter	Action/Setting
<i>RdJst</i>	<i>Adjust</i>	Set adjust value to offset temperature reading
<i>t cAL</i>	<i>T Cal</i>	Enter temperature calibration menu
<i>t Lo</i>	<i>T Low</i>	Apply the low temperature input (e.g. 32°F)
<i>t Hi</i>	<i>T High</i>	Apply the high temperature input (e.g. 1000°F)
<i>rt dtot</i>	<i>RTD Total</i>	Set the number of RTDs connected in parallel to obtain average temperature
<i>F iL tEr</i>	<i>Filter</i>	Set noise filter value
<i>bYPASS</i>	<i>Bypass</i>	Set filter bypass value
<i>round</i>	<i>Round</i>	Set the rounding value for display variables
<i>SEr iAL</i>	<i>Serial</i>	Set serial communication parameters

Display	Parameter	Action/Setting
<i>SLAVE id</i>	<i>Slave ID</i>	Set slave ID or meter address
<i>bAud</i>	<i>Baud rate</i>	Select baud rate
<i>tr dLY</i>	<i>Transmit delay</i>	Set transmit delay for serial communication
<i>PRr iLY</i>	<i>Parity</i>	Select parity Even, Odd, or None with 1 or 2 stop bits
<i>t-byt</i>	<i>Time byte</i>	Set byte-to-byte timeout
<i>SELEct</i>	<i>Select</i>	Enter the Select menu
<i>RoutPr</i>	<i>Analog output programming</i>	Program analog output parameters
<i>Source</i>	<i>Source</i>	Select source for the 4-20 mA output
<i>0-rRnG</i>	<i>Overrange</i>	Program mA output for display overrange

Display	Parameter	Action/Setting
u-rRnG	<i>Underrange</i>	Program mA output for display underrange
brERH	<i>Loop Break</i>	Set relay condition if loop break detected
rn RH	<i>Maximum</i>	Program maximum mA output allowed
rn rn	<i>Minimum</i>	Program minimum mA output allowed
LRL בו	<i>Calibrate</i>	Calibrate 4-20 mA output (internal reference source used for scaling the output)
4 rn R	<i>4 mA output</i>	Enter mA output value read by milliamp meter with at least 0.001 mA resolution
20 rn R	<i>20 mA output</i>	Enter mA output value read by milliamp meter with at least 0.001 mA resolution
u5Er	<i>User I/O</i>	Assign function keys and digital I/O
F 1	<i>F1 function key</i>	Assign F1 function key
F2	<i>F2 function key</i>	Assign F2 function key

Display	Parameter	Action/Setting
F3	<i>F3 function key</i>	Assign F3 function key
F4	<i>F4 function</i>	Assign F4 function (digital input)
d i i	<i>Digital input 1</i>	Assign digital input 1-4
dO i	<i>Digital output 1</i>	Assign digital output 1-4
LRL	<i>Internal temp calibration</i>	Enter internal temperature calibration (used for factory calibration only)
rn rEF	<i>Measured temp reference</i>	Enter the measured reference temperature in degrees Celsius (e.g. 25.0)
0mV	<i>0 mV</i>	Apply 0.000 mV input Internal Calibration
100mV	<i>100 mV</i>	Apply 100.000 mV input
dRG	<i>Diagnostics</i>	Display parameter settings
LED t	<i>LED test</i>	Test all LEDs
Inf o	<i>Information</i>	Display software and S/N information
ErRSE	<i>Erase</i>	Erase MeterView Pro software stored in meter's memory

Offset Adjust (Rd Ju5t)

This parameter allows the user to select an offset adjustment to the temperature being displayed. Offset adjustment values can be either positive or negative and can be any number within $\pm 50.0^{\circ}\text{F}$ ($\pm 27.8^{\circ}\text{C}$). The offset adjustment value is programmed through the *Adjust* menu.

The offset adjustment feature can be useful to compensate for errors due to thermocouple junctions or excessive lead wire resistance in RTDs.

Note: The offset adjustment value is not reset to zero when the type of temperature sensor is changed (i.e. TC type or RTD curve). Celsius/Fahrenheit conversion must be made manually by the user.

Recalibration of the Meter (t CAL)

The *Calibration* (t CAL) menu is used to **recalibrate** the thermocouple and RTD inputs.

- The meter is factory calibrated prior to shipment to read temperature in degrees Fahrenheit. The calibration equipment is traceable to NIST standards.
- There is no need to calibrate the meter, simply select the input type, °F or °C, and decimal point.
- Check calibration of the meter at least every 12 months.

Allow at least 30 minutes warm-up time before performing recalibration procedure to ensure specified accuracy.

Recommended Calibration Points

To recalibrate the meter, it is recommended to use the Fahrenheit scale; this will give a greater degree of accuracy to the calibration. The scale can be changed to the Celsius scale after calibration is completed. The meter will display temperature accurately in any scale. The following table shows the recommended low and high calibration points for all types.

Type of input	Input 1 (Low)	Input 2 (High)	Check (Middle)
Type J	32°F	1184°F	600°F
Type K	32°F	1895°F	960°F
Type T	32°F	698°F	360°F
Type E	32°F	1652°F	800°F
Type R	32°F	3110°F	1500°F
Type S	32°F	3110°F	1500°F
Type B	32°F	3110°F	1500°F
Type N	32°F	1472°F	700°F
Type C	500°F	3650°F	1800°F
10 Ω Cu RTD	32°F 9.035Ω	450°F 18.032Ω	200°F 12.639Ω
100 Ω Pt RTD (0.00385)	32°F 100Ω	1148°F 320.12Ω	590°F 215.61Ω
100 Ω Pt RTD (0.00392)	32°F 100Ω	1148°F 324.49Ω	590°F 217.89Ω
120 Ω Ni RTD	32°F 120Ω	410°F 315.31Ω	221°F 205.22Ω
1000 Ω Pt RTD (0.00385)	32°F 1000Ω	900°F 2750.4Ω	450°F 1876.5Ω
1000 Ω Pt RTD (0.00392)	32°F 1000Ω	900°F 2785.1Ω	450°F 1893.7Ω

Recalibration Procedure

1. Connect signal to the meter using the appropriate wire (e.g. type J thermocouple wire to recalibrate type J input), see page 15.
2. Set up the meter to accept the selected input (e.g. type J T/C), see page 29.
3. Set up the meter to display temperature in degrees Fahrenheit.
4. Apply signal corresponding to input 1 (32°F) and program the display to read 32.0.
5. Apply signal corresponding to input 2 (1184°F for type J) and program the display accordingly.
6. After the meter accepts input 2, the display returns to reading mode. This completes the recalibration procedure for the selected input.

Noise Filter (FILTER)

The noise filter is available for unusually noisy signals that cause an unstable process variable display. The noise filter averages the input signal over a certain period. The filter level determines the length of time over which the signal is averaged. The filter level can be set between 2 and 199. The higher the filter level, the longer the averaging time and so the longer it takes the display to settle to its final value. Setting the filter level to zero disables the filter function.

Noise Filter Bypass (bypass)

The noise filter bypass changes the behavior of the meter so that small variations in the signal are filtered out but large abrupt changes in the input signal are displayed immediately. The bypass value determines the minimum amount of signal change to be displayed immediately. All signal changes smaller than the bypass value are filtered or averaged by the meter. The noise filter bypass may be set between 0.1 and 99.9% of full scale.

Rounding Feature (round)

The rounding feature is used to give the user a steadier display with fluctuating signals. Rounding is used in addition to the filter function.

Rounding causes the display to round to the nearest value according to the rounding selected. This setting affects the last two digits, regardless of decimal point position. On this ProVu model, the valid settings are 1, 2, 5, and 10 (only).

Modbus RTU Serial Communications (SERIAL)

The meter is equipped with serial communications capability as a standard feature using the Modbus RTU Serial Communication Protocol.

The meter may be connected to a PC for initial configuration via the onboard micro USB connection. For ongoing digital communications with a computer or other data terminal equipment, an RS-232, or RS-485 option is required; see *Ordering Information* on page 5 for details.



Warning! Do not connect any equipment other than Precision Digital's expansion modules, cables, or meters to the RJ45 M-LINK connector. Otherwise damage will occur to the equipment and the meter.

Note: More detailed instructions are provided with each optional serial communications adapter.

Note: Refer to the ProVu® Modbus Register Tables located at www.predig.com for details.

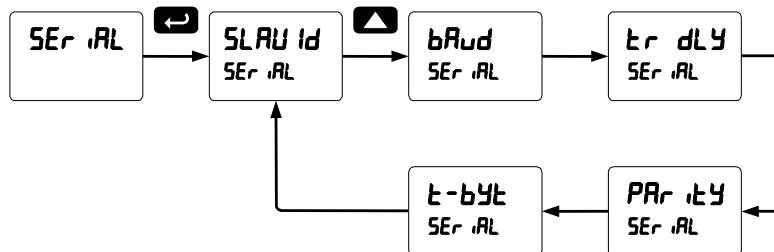

When using more than one meter in a multi-drop mode, each meter must have its own unique Slave ID or meter address. The ID or address may be programmed between 1 and 247. The transmit delay may be set between 0 and 199 ms. The parity can be set to even, odd, or none with 1 or 2 stop bits.

Serial Communications Overview

RS-232 and RS-485 are standard interfaces approved by the Electronic Industries Alliance (EIA) for connecting serial devices. In EIA terms, the device (e.g. meter) that connects to the interface is called a Data Communications Equipment (DCE) and the device to which it connects (e.g. the computer) is called a Data Terminal Equipment (DTE).

RS-485 can support multi-point connections per line because it uses lower-impedance drivers and receivers.

Line drivers and receivers are used to exchange data between two or more points (nodes) on a serial communications network. Reliable data communications can be difficult in the presence of induced noise, ground level differences, and other hazards associated with installation of a network. When communicating at high data rates, or over long distances in real world environments, RS-232 is often inadequate. The differential data transmission of RS-485 offers superior performance in most applications. Differential signals can help nullify the effects of ground shifts and induced noise signals that can appear as common mode voltages on a network.

A multi-point network consists of multiple drivers and receivers connected on a single bus, where any point (node) can transmit and/or receive data. RS-485 allows multiple drivers and receivers on the same two-wire or four-wire system. The RS-485 standard specifies up to 32 drivers and 32 receivers on a single bus, but with the introduction of "automatic" repeaters and high-impedance drivers/receivers, this number can be extended to hundreds of points (nodes) on a network.

The cabling used for an RS-485 serial communications network should always be a high quality cable such as Belden 8162 or Alpha 6203C. A two-wire system requires two twisted pairs, and a four-wire system requires three twisted pairs (the extra twisted pair is needed for the signal ground).

Figure 21 illustrates how to connect a general four-wire network (a four-wire network actually contains 5 wires).

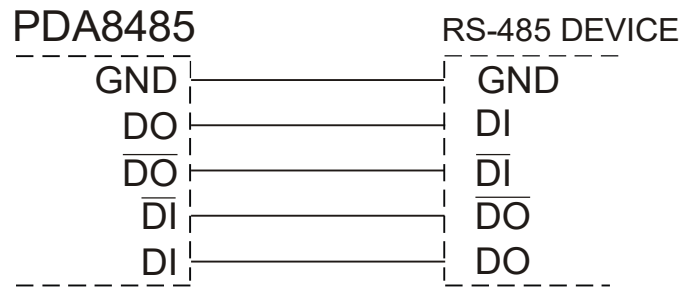

Figure 21: General Four-Wire Network Connection

Figure 22 illustrates how to connect a general two-wire network (a two-wire network actually contains 3 wires). Note that the PDA7485 and PDA8485 have DIP switches that allow for two-wire connections without the need to externally wire the DO to the DI and the /DO to the /DI (see the converter section for complete details).

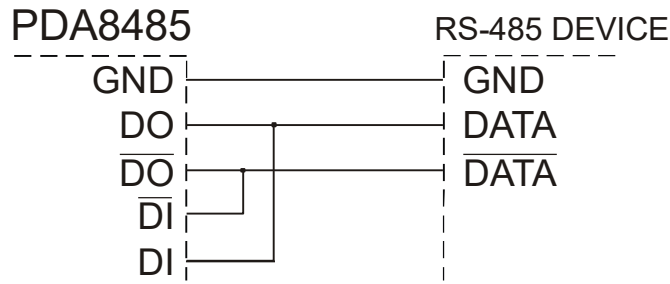
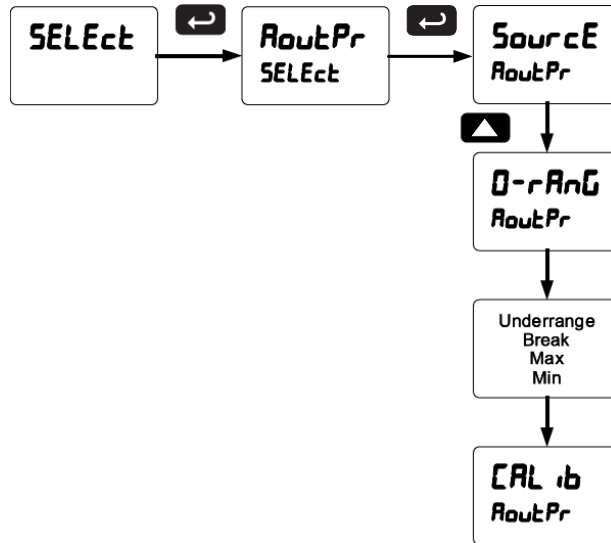

Figure 22: General Two-Wire Network Connection

Select Menu (SELEct)

The *Select* menu is used to program the analog output parameters. There are no other selections for this model.



Analog Output Programming (RoutPr)

The *Analog Output Programming* menu is used to program the behavior of the 4-20 mA output. The following parameters and functions are programmed in this menu:

1. Source: Source for generating the 4-20 mA output (e.g. PV - temperature)
2. OvrRange: Analog output value with display in overrange condition
3. Underrange: Analog output value with display in underrange condition
4. Break: Analog output value when input is detected
5. Max: Maximum analog output value allowed regardless of input
6. Min: Minimum analog output value allowed regardless of input
7. Calibrate: Calibrate the internal 4-20 mA source reference used to scale the 4-20 mA output

Analog Output Source

The source for generating the 4-20 mA output may be assigned to the process variable, maximum or minimum value reached by the process, one of the set points, or the Modbus PV input.

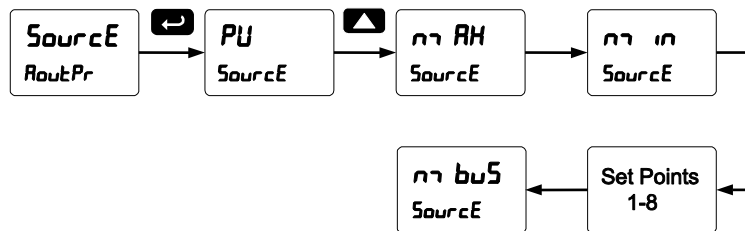

Analog Output Calibration

To perform the analog output calibration, it is recommended to use a milliamp meter with a resolution of at least 0.1 μ A to measure the output current. The values saved internally during this procedure are used for scaling the 4-20 mA output in the *Setup* menu.

Programmable Function Keys User Menu (μSEr)

The *User* menu allows the user to assign the front panel function keys F1, F2, and F3, the digital input F4 (a digital input located on the signal input connector), and up to eight additional digital inputs to access most of the menus or to activate certain functions immediately (e.g. reset max & min, hold relay states, etc.). This allows the meter to be greatly customized for use in specialized applications.

Up to eight digital outputs can be assigned to a number of actions and functions executed by the meter (i.e. alarms, relay acknowledgement, reset max, min, or max & min, tare, and reset tare). The digital outputs can be used to trigger external alarms or lights to indicate these specific events.

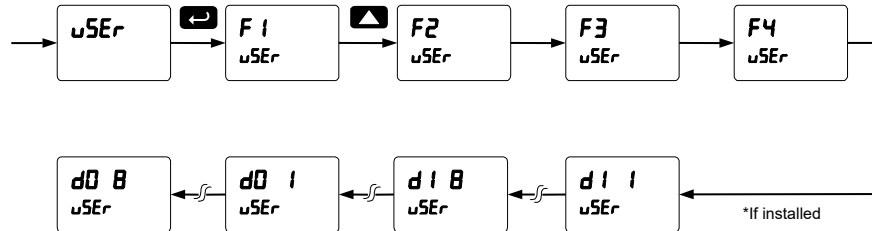

Function Keys & Digital I/O Available Settings

Refer to the following table for descriptions of each available function key or digital I/O setting.

Display	Description
r5t H1	Reset the stored maximum display value
r5t L0	Reset the stored minimum display value
r5t HL	Reset the stored maximum & minimum display values
tRrE	Capture tare and zero the display
r5t tr	Reset captured tare and resume normal operation
rELRY	Directly access the relay menu
SEt i*	Directly access the set point menu for relay 1 (*through 8)
rLY d	Disable all relays until a button assigned to <i>enable relays</i> (rLY E) is pressed
rLY E	Enable all relays to function as they have been programmed
0 Hold	Hold current relay states as they are until a button assigned to <i>enable relays</i> (rLY E) is pressed
d Hold	Hold the current display value momentarily while the function key or digital input is active. The process value will continue to be calculated in the background.
Ln1 H1	Display maximum display value on line 1
Ln1 L0	Display minimum display value on line 1
Ln1 HL	Display maximum & minimum display values on line 1

Display	Description
Ln2 H1	Display maximum display value on line 2
Ln2 L0	Display minimum display value on line 2
Ln2 HL	Display maximum & minimum display values on line 2
F On i*	Force relay 1 (*through 4) into the on state. This function is used in conjunction with a digital input to achieve interlock functionality. See page 37 for details about interlock relays.
Control	Directly access the control menu
d,SRbL	Disable the selected function key or digital I/O
RcH	Acknowledge all active relays that are in a manual operation mode such as auto-manual or latching
rESEt	Directly access the reset menu
nrnu	Mimic the menu button functionality (digital inputs only)
r,SHt	Mimic the right arrow/F1 button functionality (digital inputs only)
uP	Mimic the up arrow/F2 button functionality (digital inputs only)
EntEr	Mimic the enter/F3 button functionality (digital inputs only)
RLn1 i*	Provide indication when alarm 1 (*through 8) has been triggered (digital outputs only)

Internal Temperature Calibration (ICAL)

The meter is factory calibrated prior to shipment to read temperature in degrees Fahrenheit. The calibration equipment is traceable to NIST standards.

The Internal Calibration (ICAL) is a function used at the factory to calibrate all the thermocouple and RTD ranges. This procedure should only be used by qualified personnel.

To recalibrate the meter for a specific input and range, refer to page 42 Recalibration of the Meter (RECAL).

Notes:

1. If meter is in operation and it is intended to accept only one input type (e.g. 100 Pt), recalibration of other inputs is not necessary.
2. Allow the meter to warm up for at least 30 minutes before performing the calibration procedure.
3. Use the **Recalibration of the Meter (RECAL)** procedure found on page 42.

The *Internal calibration* menu is part of the *Advanced Features* menu and is described in the following pages. This procedure should only be used by qualified personnel.

Note: Most users should not require the use of the Internal Calibration procedure. The T CAL procedure should be used instead of the ICAL procedure.

Thermocouple Input Internal Calibration (ICAL)

1. Set the Type selector switch in the TC position and using copper wire connect a precision mV calibrator to the input.
2. In the *Setup* menu select the input: TC – Type J.
3. Press and hold the Menu button for three seconds to access the advanced features of the meter.
4. Press the Up arrow button to scroll to the *Internal calibration* menu (ICAL) and press Enter.
5. The meter displays either current calibration (REF). Press Enter to start the calibration process.
6. Measure the room temperature in degrees Celsius using a reliable reference, enter the room temperature (e.g. 25.0), and press Enter.
7. The meter displays 0 mV, apply an input equal to 0.000 mV and press Enter. The display flashes while accepting the 0 mV input; press Enter again when the display stops flashing.
8. The meter displays 100 mV, apply an input equal to 100.000 mV and press Enter. The display flashes while accepting the 100 mV input; press Enter again when the display stops flashing.
9. Apply 0 mV, the meter should read room temperature.
10. This completes the calibration of all the thermocouple ranges.

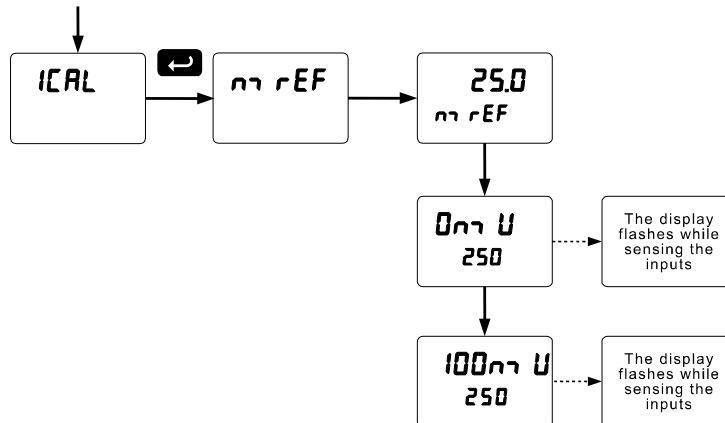

RTD Input Internal Calibration (ICAL)

1. Set the Type selector switch in the RTD position and the Range switch in the 10 position. Using 3 wires connect a precision calibrator resistance output to the meter.
2. In the *Setup* menu select the input: RTD – 100 Pt – A385.
3. Access the *Advanced Features* menu and scroll to the *ICAL* menu and press Enter.
4. The meter displays the message (10 Lo). Apply 9.035 ohm and press Enter. The display flashes for a moment while the meter is accepting the low input signal for the 10-ohm RTD. After the display stops flashing, press Enter again.
5. The meter displays the message (10 Hi). Apply 18.032 ohm and press Enter. The display flashes for a moment while the meter is accepting the high input signal for the 10-ohm RTD. After the display stops flashing, press Enter again.
6. The meter displays the message (100 Lo). **Do NOT press Enter.**
7. Move the Range selector switch to the 100 position. Apply 100 ohm and press Enter. The display flashes for a moment while the meter is accepting the low input signal for the 100-ohm RTD.
8. The meter displays the message (100 Hi). Apply 320.12 ohm and press Enter. The display flashes for a moment while the meter is accepting the high input signal for the 100-ohm RTD.
9. At the end of the calibration process the meter should read 1148.0F with the 320.12-ohm input applied.
10. This completes the calibration of all the RTD ranges.

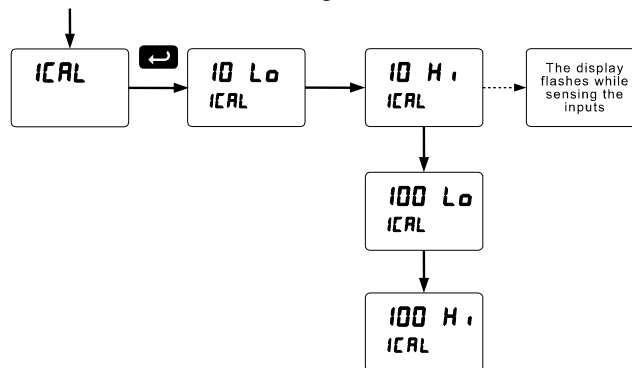









Meter Operation

The meter is capable of accepting a variety of thermocouples and RTDs.

The dual-line display can be customized by the user to operate in such a way as to satisfy a specific application. Typically, display line 1 is used for the process variable; while line 2 is used engineering units, custom legend, or set point indication.

Additionally, the meter can be set up to display the thermocouple or RTD input on line 1 and the Modbus input on line 2. The relays and analog output can be programmed to operate from the Modbus PV input.

Front Buttons Operation

Button Symbol	Description
 or 	Press to enter or exit Programming Mode, view settings, or exit max/min readings
 or 	Press to reset max readings or other parameter/function assigned through the <i>User</i> menu
 or 	Press to display max/min readings or other parameter/function assigned through the <i>User</i> menu
 or 	Press to acknowledge relays or other parameters/function assigned through the <i>User</i> menu

SafeTouch[®] Buttons

The ProtEX-MAX is equipped with four sensors that operate as through-glass buttons so that it can be programmed and operated without removing the cover (and exposing the electronics) in a hazardous area.

These buttons can be disabled for security by selecting DISABLE on the switch labeled NO-CONTACT BUTTONS located on the connector board.

To actuate a button, press one finger to the glass directly over the marked button area. Then retract finger more than three inches from the glass before pressing the next button. When the cover is removed, the four mechanical buttons located next to the sensors are used. The sensors are disabled when a mechanical button is pressed and will automatically be re-enabled after 60 seconds of inactivity.

The SafeTouch Buttons are designed to filter normal levels of ambient interference and to protect against false triggering, however, it is recommended that the SafeTouch Buttons be disabled (slide switch to LOCK) if there is an infrared interference source in line-of-sight to the display.

The SafeTouch Buttons are configured by default to duplicate the function of the front panel mechanical pushbuttons associated with the integrated meter. The symbols by each SafeTouch button correspond to a mechanical button as shown in the above table.

SafeTouch Button Tips:

- To the extent possible, install the display facing away from sunlight, windows, reflective objects and any sources of infrared interference.
- Keep the glass window clean.
- Tighten the cover securely.
- Use a password to prevent tampering.



Take caution when cleaning the window glass as it may result in unintentional Safe-Touch button events. Only clean the ProtEX-MAX when the system is safely shut down, and inspect the ProtEX-MAX for proper configuration prior to system restart.

F4 Operation

A digital input, F4, is standard on the meter. This digital input is programmed identically to function keys F1, F2, and F3. The input is triggered with a contact closure to COM, or with an active low signal. During operation, F4 operates according to the way it has been programmed in the *Advanced Features – User* menu.

Maximum/Minimum Readings

The max & min readings (peak & valley) reached by the process can be displayed either continuously or momentarily:

1. Display briefly by assigning to the F1-F3 function keys or to the digital inputs in the *User* menu.
2. Display continuously by assigning either display to max/min through the *Display* menu.

Any of the F1-F3 function keys (buttons) and the digital inputs can be programmed to reset the max & min readings. The meters are set at the factory to display the max reading by pressing the Up arrow/F2 button and to use the Right arrow/F1 button to access the *Reset* menu.

To display max reading using function key with factory defaults:

1. Press Up arrow/F2 button to display maximum reading since the last reset/power-up.
2. To reset max/min press Right arrow/F1 button to access the Reset menu. The max & min displays are reset to actual values.
3. Press Menu to exit max/min display reading.

To display max/min readings continuously:

Assign either display to Max (d H i), Min (d Lo), or toggle between Max and Min (d HL) every 10 seconds.

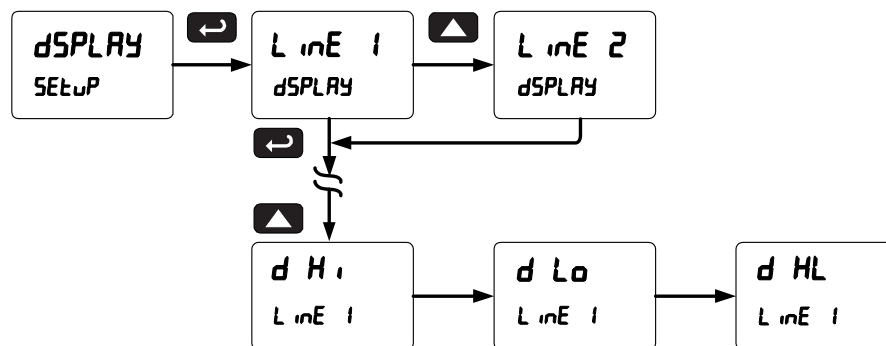

Troubleshooting

The rugged design and the user-friendly interface of the meter should make it unusual for the installer or operator to refer to this section of the manual. However, due to the many features and functions of the meter, it's possible that the setup of the meter does not agree with what an operator expects to see. If the meter is not working as expected, refer to the *Diagnostics* menu and recommendations below.

Diagnostics Menu (d ,RG)

The *Diagnostics* menu is located in the *Advanced Features* menu, to access *Diagnostics* menu see *Advanced Features Menu*, page 40.

This menu allows the user to test the functionality of all the meter LEDs, check the meter's software and version information, and erase the MeterView Pro software installation files from the meter. Press the Enter button to view the settings and the Menu button to exit at any time.

For a description of the diagnostic messages, see *Advanced Features Menu & Display Messages*, page 40.

Determining Software Version

To determine the software version of a meter:

1. Go to the *Diagnostics* menu (d ,RG) and press Enter button.
2. Press Up arrow button and scroll to Information menu (InFo).
3. Press Enter to access the software number (5Ft) and version (UEr) information. Write down the information as it is displayed. Continue pressing Enter until all the information is displayed.
4. The meter returns to Run Mode after displaying all the settings.

Reset Meter to Factory Defaults

When the parameters have been changed in a way that is difficult to determine what's happening, it might be better to start the setup process from the factory defaults.

Instructions to load factory defaults:

1. Enter the *Advanced Features* menu. See *Advanced Features Menu*, page 40.
2. Press Up arrow to go to *Diagnostics* menu
3. Press and hold Right arrow for three seconds, press Enter when display flashes rESEt.
Note: If Enter is not pressed within three seconds, the display returns to the *Diagnostics* menu.
4. The meter goes through an initialization sequence (similar as on power-up), and loads the factory default settings.

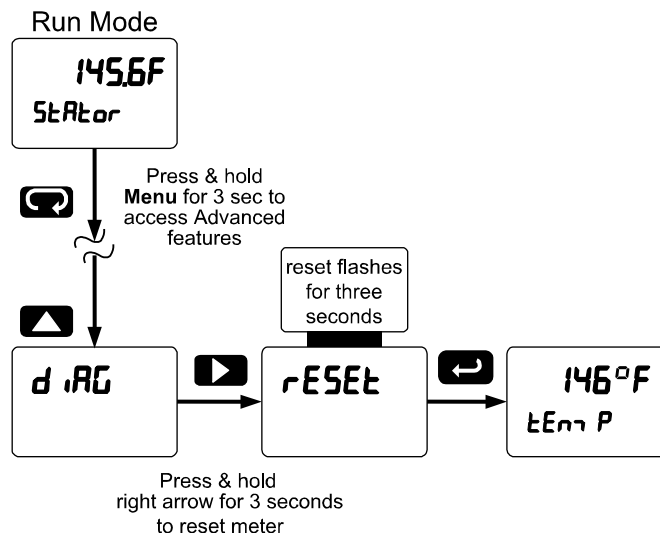

Factory Defaults & User Settings

The following table shows the factory setting for most of the programmable parameters on the meter.

Parameter	Display	Default Setting
Input type	<i>INPut</i>	Type J TC
Temp scale	<i>F or C</i>	°F
Adjust	<i>ADJUSt</i>	0.0
RTD total	<i>rtdtot</i>	1
Filter	<i>FILtEr</i>	70
Bypass	<i>bYPASS</i>	0.2
Round	<i>round</i>	1
Decimal point	<i>ddd°F</i>	No decimal
Display line 1	<i>Line 1</i>	PV: Temperature
Display line 2	<i>Line 2</i>	Eng units: Temp
Display intensity	<i>d-intY</i>	8
Relay 1 action	<i>Act 1</i>	Automatic
Relay 1 set point	<i>SEt 1</i>	100
Relay 1 reset point	<i>rSt 1</i>	50
Relay 2 action	<i>Act 2</i>	Automatic
Relay 2 set point	<i>SEt 2</i>	200
Relay 2 reset point	<i>rSt 2</i>	150
Relay 3 action	<i>Act 3</i>	Automatic
Relay 3 set point	<i>SEt 3</i>	300
Relay 3 reset point	<i>rSt 3</i>	250
Relay 4 action	<i>Act 4</i>	Automatic
Relay 4 set point	<i>SEt 4</i>	400
Relay 4 reset point	<i>rSt 4</i>	350
Fail-safe relay 1	<i>FLS 1</i>	Off
Fail-safe relay 2	<i>FLS 2</i>	Off
Fail-safe relay 3	<i>FLS 3</i>	Off
Fail-safe relay 4	<i>FLS 4</i>	Off
On delay relay 1	<i>On 1</i>	0.0 sec
Off delay relay 1	<i>OFF 1</i>	0.0 sec
On delay relay 2	<i>On 2</i>	0.0 sec
Off delay relay 2	<i>OFF 2</i>	0.0 sec
On delay relay 3	<i>On 3</i>	0.0 sec
Off delay relay 3	<i>OFF 3</i>	0.0 sec
On delay relay 4	<i>On 4</i>	0.0 sec
Off delay relay 4	<i>OFF 4</i>	0.0 sec
Input break relay 1	<i>IGNorE</i>	Ignore

Parameter	Display	Default Setting
Input break relay 2	<i>IGNorE</i>	Ignore
Input break relay 3	<i>IGNorE</i>	Ignore
Input break relay 4	<i>IGNorE</i>	Ignore
Display 1 analog out	<i>d i 1</i>	0.0
Output 1 value	<i>Out 1</i>	4.000 mA
Display 2 analog out	<i>d i 2</i>	2000.0
Output 2 value	<i>Out 2</i>	20.000 mA
Source analog output	<i>Source</i>	Process Variable
Overrange output	<i>OverranG</i>	21.000 mA
Underrange output	<i>UnderranG</i>	3.000 mA
Input break output	<i>brERH</i>	1.000 mA
Maximum output	<i>max RH</i>	23.000 mA
Minimum output	<i>min RH</i>	1.000 mA
Slave ID	<i>SLAVE Id</i>	247
Baud rate	<i>baud</i>	9600
Transmit delay	<i>tr dLY</i>	10 ms
Parity	<i>PARr itY</i>	Even
Byte-to-byte timeout	<i>t-byt</i>	010 (0.1 sec)
F1 function key	<i>F 1</i>	Reset max & min
F2 function key	<i>F 2</i>	Line 1: Max (Hi)
F3 function key	<i>F 3</i>	Acknowledge relays
F4 function	<i>F 4</i>	Acknowledge relays
Digital input 1	<i>d i 1</i>	Menu
Digital input 2	<i>d i 2</i>	Right arrow
Digital input 3	<i>d i 3</i>	Up arrow
Digital input 4	<i>d i 4</i>	Enter
Digital output 1	<i>dO 1</i>	Alarm 1
Digital output 2	<i>dO 2</i>	Alarm 2
Digital output 3	<i>dO 3</i>	Alarm 3
Digital output 4	<i>dO 4</i>	Alarm 4
Password 1	<i>PASS 1</i>	000000 (unlocked)
Password 2	<i>PASS 2</i>	000000 (unlocked)
Password 3	<i>PASS 3</i>	000000 (unlocked)

Troubleshooting Tips

Symptom	Check/Action
SafeTouch buttons do not respond	If mechanical button was pushed. The SafeTouch buttons will be re-enabled automatically 60 seconds after the last button push. If slide switch on connector board is in DISABLE position, switch to ENABLE. Strong direct sunlight may interfere with SafeTouch button operation. It is recommended to operate the buttons by standing so as to block direct sunlight.
Serial Communications Power LED Indicator is off	1. Check modular cable connection Check power to the device
If only the TX (or DATA IN) data status LED is flashing when serial communications attempted	1. Check serial cable 2. Check protocol selected on device 3. Check instrument address & baud rate Check program address & baud rate
If both data status LEDs (TX and RX) are off when trying to communicate	Remove all unnecessary cables and instruments from the bus. Try getting the system to work with only one device (to ease troubleshooting) and then expand the system one device at a time.
Communications slow	Increase the baud rate
Random communication errors	1. Increase the TX delay time Decrease the baud rate
Power LED is off	1. Check modular cable connection Check power to instrument
No display at all	Check power at power connector
Not able to change setup or programming, <i>L o c k</i> is displayed	Meter is password-protected, enter correct six-digit password to unlock
Meter displays error message during calibration (<i>E r r o r</i>)	Check: 1. Signal connections 2. Type and range selector switches 3. Input selected in <i>S e t u p</i> menu
Meter displays 1. <i>99999</i> 2. <i>-9999</i>	Check: 1. Input selected in <i>S e t u p</i> menu 2. Corresponding signal at Signal connector
Display is unstable	Check: 1. Input signal stability and value 2. Filter and bypass values (increase)
Display response is too slow	Check filter and bypass values
Display reading is not accurate	Check: 1. TC wire type 2. Input selection in <i>S e t u p</i> menu
Display does not respond to input changes, reading a fixed number	Check: 1. Display assignment, it might be displaying max, min, or set point.
Display alternates between 1. <i>H i</i> and a number 2. <i>L o</i> and a number	Press Menu to exit max/min display readings.
Relay operation is reversed	Check: 1. Fail-safe in <i>S e t u p</i> menu 2. Wiring of relay contacts

Symptom	Check/Action
Relay and status LED do not respond to signal	Check: 1. Relay action in <i>Setup</i> menu 2. Set and reset points
Flashing relay status LEDs	Relays in manual control mode or relay interlock switches opened.
Meter not communicating with application programs	Check: 1. Serial adapter and cable 2. Serial settings 3. Meter address and baud rate
If the display locks up or the meter does not respond at all	Cycle the power to reboot the microprocessor.
Other symptoms not described above	Call Technical Support for assistance.

Note: Certain sequences of events can cause unexpected results. To solve these issues, it is best to start fresh from factory defaults and map changes ahead of time, rather than at random.

Service



WARNINGS

- Installation and service should be performed only by trained service personnel. Service requiring replacement of internal sub-components must be performed at the factory.
- Disconnect from supply before opening enclosure. Keep cover tight while circuits are alive. Conduit seals must be installed within 18" (450mm) of the enclosure.
- Verify that the operating atmosphere of the instrument is consistent with the appropriate hazardous locations certifications.
- If the instrument is installed in a high voltage environment and a fault or installation error occurs, high voltage may be present on any lead
- Read all product labels completely and follow all instructions and requirements listed on the labels for installation or service.

If the enclosure is sound and undamaged, then only the internal electronics housing will need to be returned to the factory for service. Contact the factory for RMA number and return instructions.

Mounting Dimensions

All units: inches (mm)

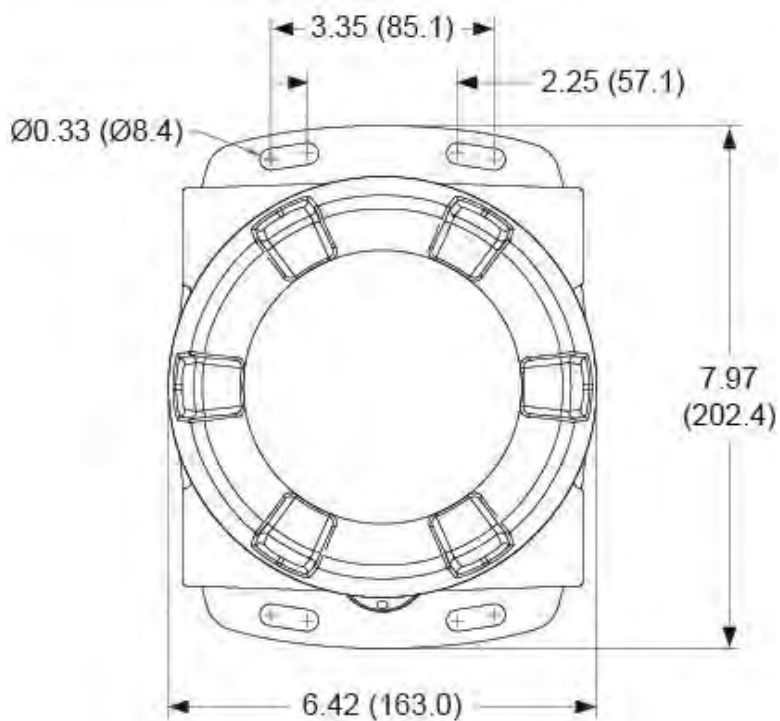

Figure 23: Enclosure Dimensions – Front View

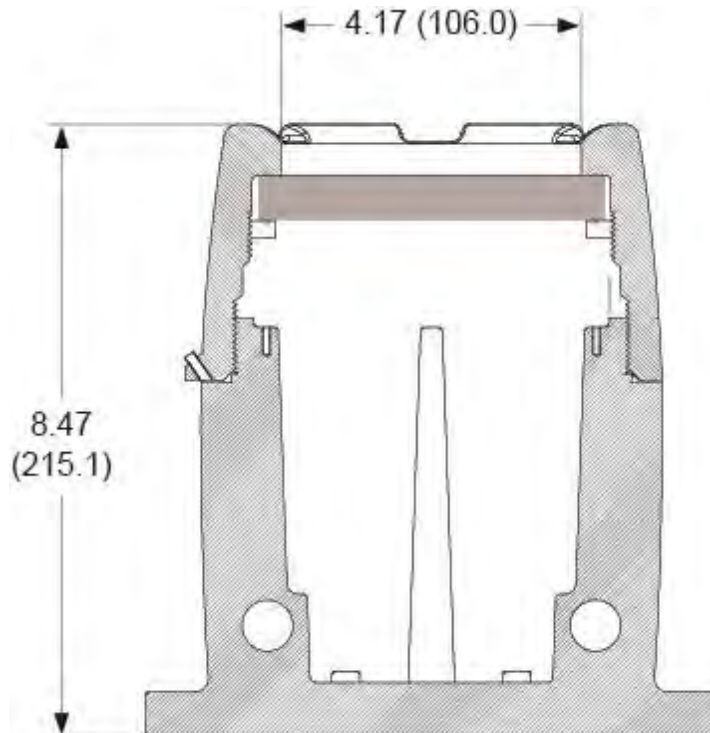

Figure 24: Enclosure Dimensions – Side Cross Section View

This Page Intentionally Left Blank

EU Declaration of Conformity

Issued in accordance with ISO/IEC 17050-1:2004 and ATEX Directive 2014/34/EU.

We,

Precision Digital Corporation
233 South Street
Hopkinton, MA 01748 USA

as the manufacturer, declare under our sole responsibility that the product(s),

Model PD8 ProtEX-MAX Series

to which this declaration relates, is in conformity with the European Union Directives shown below:

2014/35/EU	Low Voltage Directive
2014/34/EU	ATEX Directive
2014/30/EU	EMC Directive
2011/65/EU	RoHS Directive

This conformity is based on compliance with the application of harmonized or applicable technical standards and, when applicable or required, a European Union notified body certification.

Standards:

EN 55022:2007	EN 61000-6-2:2005	EN 60079-0:2009	EN 61000-6-4:2007
EN 60079-1:2007	EN 61010-1:2001	EN 60079-31:2008	EN 61326:2006

The standards EN 55022:2007, EN 60079-0:2009, EN 60079-1:2007, EN 60079-31:2008, EN 61000-6-4:2007, EN 61010-1:2001, and EN 61326:2006 are no longer harmonized. The requirements of these standards have been checked against the harmonized standard EN 55022:2010, EN 60079-0:2012+A11:2013, EN 60079-1:2014, EN 60079-31:2014, EN 61000-6-4:2007+A1:2011, EN 61010-1:2010, and EN 61326:2013 and there were no major technical changes affecting the latest technical knowledge for the products listed above.

EC Type Examination Certificate: Sira 12ATEX1182

Product Markings:

 II 2 G D
Ex d IIC T* Gb
Ex tb IIIC T90°C Db IP68
Tamb = -40°C to +*C (*T5 = 65°C, *T6 = 60°C)

ATEX Notified Body for EC Type Examination Certificate: Sira Certification Service, NB 0518
Unit 6, Hawarden Industrial Park
Hawarden, Deeside, CH5 3US, UK

ATEX Quality Assurance Notification No.: SIRA 10 ATEX M462

ATEX Notified Body for Quality Assurance: Sira Certification Service, NB 0518
Unit 6, Hawarden Industrial Park
Hawarden, Deeside, CH5 3US, UK

Signed for and on behalf of Precision Digital Corporation:



Name: Jeffrey Peters
Company: Precision Digital Corporation
Title: President
Date: 02/12/2018



Document No: DoC PD8 {021218}

How to Contact Precision Digital

- For Technical Support, please
Call: (800) 610-5239 or (508) 655-7300
Fax: (508) 655-8990
Email: support@predig.com
- For Sales Support or to place an order, please contact your local distributor or
Call: (800) 343-1001 or (508) 655-7300
Fax: (508) 655-8990
Email: sales@predig.com
- For the latest version of this manual, please visit
www.predig.com

PRECISION DIGITAL CORPORATION

233 South Street • Hopkinton MA 01748 USA
Tel (800) 343-1001 • Fax (508) 655-8990



www.predig.com