

ProtEX-MAX PD8-6363 Explosion-Proof Dual Pulse Input Rate/Totalizer Instruction Manual



Rate/Totalizer

- Two (2) Pulse, Open Collector, NPN, PNP, TTL, Switch Contact, Sine Wave (Coil), Square Wave Inputs
- Displays Two Flow Inputs Simultaneously
- Displays Rate and Total Simultaneously
- Math Functions Capabilities
- 5, 10, or 24 V Flowmeter Power Supply
- Count Up or Down, Total & Grand Total
- Gate Function for Rate Display of Slow Pulse Rates
- K-Factor, Internal Scaling, or External Calibration
- Non-Resettable Grand Total
- Modern, Sleek and Practical Enclosure
- Display Mountable at 0°, 90°, 180°, & 270° Degrees
- Explosion-Proof, IP68, NEMA 4X Enclosure
- SafeTouch® Through-Glass Button Programming
- Flanges for Wall or Pipe Mounting
- Superluminous Sunlight Readable Display
- Free USB Programming Software & Cable
- 2 or 4 Relays + Isolated 4-20 mA Output Options

PRECISION DIGITAL CORPORATION

233 South Street • Hopkinton MA 01748 USA
Tel (800) 343-1001 • Fax (508) 655-8990

PRECISION
DIGITAL

www.predig.com

Disclaimer

The information contained in this document is subject to change without notice. Precision Digital makes no representations or warranties with respect to the contents hereof and specifically disclaims any implied warranties of merchantability or fitness for a particular purpose.



CAUTION: *Read complete instructions prior to installation and operation of the meter.*



WARNING: *Risk of electric shock or personal injury.*



Warning!

- ***This product is not recommended for life support applications or applications where malfunctioning could result in personal injury or property loss. Anyone using this product for such applications does so at his/her own risk. Precision Digital Corporation shall not be held liable for damages resulting from such improper use.***
- ***Failure to follow installation guidelines could result in death or serious injury. Make sure only qualified personnel perform the installation.***
- ***Never remove the instrument cover in explosive environments when the circuit is live.***
- ***Cover must be fully engaged to meet flameproof/explosion-proof requirements.***
- ***Information in this manual supersedes all enclosure, compliance, and agency approval information included in additional product manuals included with this product.***

Limited Warranty

Precision Digital Corporation warrants this product against defects in material or workmanship for the specified period under “Specifications” from the date of shipment from the factory. Precision Digital’s liability under this limited warranty shall not exceed the purchase value, repair, or replacement of the defective unit.

Registered Trademarks

MeterView® Pro is a registered trademark of Precision Digital Corporation. Modbus® is a Registered Trademark of Schneider Automation Inc. All other trademarks mentioned in this document are the property of their respective owners.

© 2018 Precision Digital Corporation. All rights reserved.

www.predig.com

Table of Contents

Table of Contents	3	Setting the Decimal Point (<i>dEc Pt</i>)	32
Table of Figures	4	Programming the Rate/Totalizer (<i>PrOg</i>)	33
Introduction	4	Input Calibration Method (<i>inCAL</i>)	33
Ordering Information	5	K-Factor Calibration (<i>FRct - R, FRct - b</i>)	33
Specifications	5	Scaling the Meter without a Signal Source (<i>SCAL - R, SCAL - b</i>)	34
General	5	Scaling the Meter for Channel A (<i>SCAL - R</i>)	34
Dual Pulse Inputs	6	Error Message (<i>Error</i>)	34
Dual Rate/Totalizer	7	Calibrating the Meter with External Source (<i>CAL - R, CAL - b</i>)	35
Relays	7	Totalizer Setup (<i>tSEtUP</i>)	36
Isolated 4-20 mA Transmitter Output	8	Total & Grand Total Reset (<i>tRESEt</i>)	36
Digital Inputs & Outputs	8	Setting the Display Parameters & Intensity (<i>dSPLY</i>)	37
Serial Communications	8	Setting the Relay Operation (<i>rELAY</i>)	38
MeterView Pro	8	Setting the Relay Assignment (<i>R55, n</i>)	38
Product Ratings and Approvals;	9	Setting the Relay Action (<i>Rct</i>)	39
Compliance Information	10	Programming Set and Reset Points	39
Safety	10	Setting Fail-Safe Operation	39
Electromagnetic Compatibility	10	Programming Time Delay	39
Safety Information	11	Relay and Alarm Operation Diagrams	40
Installation	11	High Alarm Operation (Set > Reset)	40
Unpacking	11	Low Alarm Operation (Set < Reset)	40
Pre-Installed Conduit/Stopping Plug	12	High Alarm with Fail-Safe Operation (Set > Reset)	40
Mounting	12	Low Alarm with Fail-Safe Operation (Set < Reset)	40
Cover Jam Screw	12	Pump Alternation Control Operation	41
Transmitter Supply Voltage Selection (P+, P-) ----	12	Relay Sampling Operation	41
Connections	13	Total Relay Sampling Operation	42
Required & Factory Wired Connection	13	Time Delay Operation	42
Connectors Labeling	14	Relay Operation Details	43
Power Connections	14	Overview	43
Signal Connections	15	Relays Auto Initialization	43
Configure Input Type and Level Switches	15	Fail-Safe Operation	43
Serial Communications Connections	16	Front Panel LEDs	43
Three Wire Connections	16	Latching and Non-Latching Relay Operation	44
Using PROVU Serial Adapters	18	Non-Latching Relay (<i>Ruta</i>)	44
Relay Connections	19	Non-Latching Relay (<i>R-nn Rn</i>)	44
Switching Inductive Loads	19	Latching Relay (<i>LRECH</i>)	44
F4 Digital Input Connections	20	Latching Relay (<i>Lt-CLR</i>)	44
4-20 mA Output Connections	20	Acknowledging Relays	45
Analog Output Transmitter Power Supply	20	Setting Up the Interlock Relay (Force On) Feature	45
Interlock Relay Feature	20	Scaling the 4-20 mA Analog Output (Rout) -----	45
Digital I/O Connections	21	Reset Menu (rESEt) -----	46
External Switch Contacts	21	Control Menu (Contrl) -----	46
Setup and Programming	22	Setting Up the Password (PR55) -----	46
SafeTouch® Buttons	22	Protecting or Locking the Meter Functions	46
Front Buttons and Status LED Indicators	23	Total Reset Password & Non-Resettable Total	47
MeterView® Pro Software	24	Making Changes to a Password Protected Meter	47
MeterView Pro Installation	24	Disabling Password Protection	47
Display Functions & Messages	25	Advanced Features Menu	48
Main Menu	28	Advanced Features Menu & Display Messages	48
Setting Numeric Values	29	Gate Function (<i>GRtE</i>)	50
Setting Up the Meter (SEtUP)	29	Contact De-Bounce Filter (<i>FiltEr</i>)	51
Setting the Input Signal (<i>inPUL</i>)	30	Rounding Feature (<i>round</i>)	51
Setting the Totalizer Features (<i>tOtAL</i>)	30	Modbus RTU Serial Communications (<i>SEr, RL</i>)	51
Setting the Dual-Input Mode (<i>modE</i>)	30	Serial Communications Overview	52
Setting the Rate, Total, & Grand Total Units/Tags (<i>un tS</i>)	32	Select Menu (<i>SELEct</i>)	53
		Signal Input Conditioning (<i>Functn</i>)	53

Multi-Point Linearization (L _{inERr})-----	53	Troubleshooting -----	60
Math Function (M _{th})-----	54	Diagnostics Menu (d_{AG}) -----	60
Math Constants (C _{onSt})-----	54	Determining Software Version-----	60
Low-Flow Cutoff (L _{oWtOFF})-----	55	Reset Meter to Factory Defaults -----	60
Totalizer Count Up/Down (C _{ouNt})-----	55	Factory Defaults & User Settings-----	61
Analog Output Programming (A _{oUtPr})-----	55	Troubleshooting Tips -----	62
Programmable Function Keys User Menu (u _{5Er})-----	56	Service -----	64
Meter Operation -----	58	Mounting Dimensions -----	64
Front Buttons Operation-----	58	EU Declaration of Conformity -----	65
SafeTouch® Buttons-----	58		
F4 Operation-----	59		
Maximum/Minimum Readings-----	59		

Table of Figures

Figure 1. Transmitter Supply Voltage Selection.....	12	Figure 16. AC and DC Loads Protection.....	19
Figure 2: Integrated ProVu Required Connections ..	13	Figure 17. Low Voltage DC Loads Protection	19
Figure 3. Connector Labeling for Fully Loaded PD8-6363	14	Figure 18. F4 Digital Input Connections	20
Figure 4. Power Connections.....	14	Figure 19. 4-20 mA Output Connections.....	20
Figure 5: Flowmeter Powered by Internal Power Supply	15	Figure 20. Interlock Connections	20
Figure 6: Flowmeter Powered by External Supply ...	15	Figure 21: Digital I/O Connections	21
Figure 7: Self-Powered Magnetic Pickup Coil Flowmeter	15	Figure 22. Dual Input Mode (u _{d Rb}).....	30
Figure 8: NPN open Collector Input.....	15	Figure 23. Dual Input Mode (u _{d R l}).....	30
Figure 9: PNP Sensor Powered by Internal Supply..	15	Figure 24. Dual Input Mode (u _{d b l}).....	31
Figure 10: Switch Input Connections	15	Figure 25. Dual Input Mode (q _{uRd l}).....	31
Figure 11: ProtEX-MAX Connections to a Serial Converter	16	Figure 26. Dual Input Mode (q _{uRd 2}).....	31
Figure 12. Three-Wire RS485 Connection.....	16	Figure 27. Dual Input Mode (q _{uRd 4}).....	31
Figure 13: RS-485 Wiring.....	17	Figure 28. Acknowledge Relays w/Function Key or Digital Input	45
Figure 14: RS-485 Two-Wire Multi-Drop Wiring.....	18	Figure 29: General Four-Wire Network Connection..	52
Figure 15. Relay Connections	19	Figure 30: General Two-Wire Network Connection...52	
		Figure 31: Enclosure Dimensions – Front View	64
		Figure 32: Enclosure Dimensions – Side Cross Section View.....	64

Introduction

The ProtEX-MAX PD8-6363 offers all the functionality of the ProVu PD6363 as a fully FM, CSA, ATEX, and IECEx approved explosion-proof product. It is specifically designed to display flow rate and total from two (2) pulse output (NPN, PNP, TTL, switch contact, sine wave, etc.) flowmeters. It displays these signals on a dual-line, 6-digit SunBright® sunlight readable display. The two display lines can be used to show both flow rates simultaneously, to alternate between the two inputs showing both the flow rate and total of each, or to show the result of math functions performed on the flow rates and totals. The total overflow feature allows up to 9-digit totals and grand totals to be displayed. The PD8-6363 includes a 24 VDC power supply to drive the flowmeter and can be equipped with up to four internal relays and a 4-20 mA analog output. It can be programmed and operated without opening the housing by using the built-in SafeTouch® through-glass buttons or the RS485 serial communication port with free Modbus® protocol.

Ordering Information

SunBright Display Models

85-265 VAC Model	12-24 VDC Model	Options Installed
PD8-6363-6H0	PD8-6363-7H0	No options
PD8-6363-6H2	PD8-6363-7H2	2 relays
PD8-6363-6H3	PD8-6363-7H3	4-20 mA output
PD8-6363-6H4	PD8-6363-7H4	4 relays
PD8-6363-6H5	PD8-6363-7H5	2 relays & 4-20 mA output
PD8-6363-6H7	PD8-6363-7H7	4 relays & 4-20 mA output

Accessories

Model	Description
PDA1232	RS-232 serial adapter
PDA1485	RS-485 serial adapter
PDA7485-I	RS-232 to RS-422/485 isolated converter
PDA7485-N	RS-232 to RS-422/485 non-isolated converter
PDA8232-N	USB to RS-232 non-isolated converter
PDA8485-I	USB to RS-422/485 isolated converter
PDA8485-N	USB to RS-422/485 non-isolated converter
PDX6901	Suppressor (snubber): 0.01 μ F/470 Ω , 250 VAC

Specifications

Except where noted all specifications apply to operation at +25°C.

General

Display	Line 1: 0.60" (15 mm) high, red LEDs Line 2: 0.46" (12 mm) high, red LEDs 6 digits each (-99999 to 999999), with lead zero blanking
Display Intensity	Eight user selectable intensity levels
Display Update Rate	Rate: 10 per second; up to 1 per 100 seconds (and is a function of Low Gate setting); Total: 10 per second (fixed)
Overrange	Display flashes 999999
Programming Methods	Four front panel buttons, digital inputs, PC and MeterView Pro software, or Modbus registers.
Max/Min Display	Max/min readings reached by the process are stored until reset by the user or until power to the meter is cycled.
Recalibration	All ranges are calibrated at the factory. Recalibration is recommended at least every 12 months.
Non-Volatile Memory	All programmed settings are stored in non-volatile memory for a minimum of ten years if power is lost.
Connections	Screw terminals accept 12 to 22 AWG wire

Display Assignment	<p>Display lines 1 & 2 may be assigned to show:</p> <ul style="list-style-type: none"> One or more rate/math channels: Channel A (Ch-A), B (Ch-B), or C (Ch-C) Toggle rate/math channels: Ch-A & Ch-B, Ch-A & Ch-C, Ch-B & Ch-C, and Ch-A, Ch-B, & Ch-C Total or grand total: Ch-A or Ch-B Rate and total or grand total: Ch-A or Ch-B Relay set points Max and/or min values: Ch-A, Ch-B, or Ch-C Toggle between any rate/math channel & units Total and units: Ch-A or Ch-B Toggle between totals: Ch-A & Ch-B; Ch-A, Ch-B, and sum of Ch-A and Ch-B Modbus input <p>The lower display may also be set to show engineering units or be off, with no display.</p>
Fuse	Required external fuse: UL Recognized, 5 A max, slow blow; up to 6 meters may share one 5 A fuse

Password	Three programmable passwords restrict modification of programmed settings and two prevent resetting the totals. Pass 1: Allows use of function keys and digital inputs Pass 2: Allows use of function keys, digital inputs and editing set/reset points Pass 3: Restricts all programming, function keys, and digital inputs. Total: Prevents resetting the total manually Gtotal: Prevents resetting the grand total manually
Power Options	85-265 VAC 50/60 Hz, 90-265 VDC, 20 W max or 12-24 VDC ± 10%, 15 W max Powered over USB for configuration only
Isolated Transmitter Power Supply	Terminals P+ & P-: 24 VDC ± 10%. Selectable for 24, 10, or 5 VDC supply (internal jumper J4). All models transmitter supply rated @ 25 mA max.
Isolation	4 kV input/output-to-power line 500 V input-to-output or output-to-P+ supply
Overvoltage Category	Installation Overvoltage Category II: Local level with smaller transient overvoltages than Installation Overvoltage Category III.
Environmental	T6 Class operating temperature range Ta = -40 to 60°C T5 Class operating temperature range Ta = -40 to 65°C
Max Power Dissipation	Maximum power dissipation limited to 15.1 W.
Enclosure	Explosion-proof die cast aluminum with glass window, corrosion resistant epoxy coating, color: blue. NEMA 4X, 7, & 9, IP68. Default conduit connections: Four 3/4" NPT threaded conduit openings and two 3/4" NPT metal conduit plugs with 12 mm hex key fitting installed. Additional conduit opening configurations may be available; verify quantity and sizes on specific device labeling during installation.
Mounting	Four slotted flanges for wall mounting or NPS 1 1/2" to 2 1/2" or DN 40 to 65 mm pipe mounting. See Mounting Dimensions on page 64.
Tightening Torque	Screw terminal connectors: 5 lb-in (0.56 Nm)
Overall Dimensions	6.42" x 7.97" x 8.47" (W x H x D) (163 mm x 202 mm x 215 mm)
Weight	16.0 lbs (7.26 kg)
Warranty	3 years parts & labor

Dual Pulse Inputs

Two Inputs	Field selectable: Pulse or square wave 0-5 V, 0-12 V, or 0-24 V @ 30 kHz; TTL; open collector 4.7 kΩ pull-up to 5 V @ 30 kHz; NPN or PNP transistor, switch contact 4.7 kΩ pull-up to 5 V @ 40 Hz; Modbus PV (Slave)
Channels	Channel A, Channel B, Channel C (Math channel)

Programmable Constants	Constant P (Adder): -99.999 to 999.999, default: 0.000 Constant F (Factor): 0.001 to 999.999, default: 1.000
-------------------------------	---

Math Functions		
Name	Function	Setting
Addition	$(A+B+P)*F$	5000
Difference	$(A-B+P)*F$	d if
Absolute diff.	$((Abs(A-B))+P)*F$	d if Ab5
Average	$((A+B)/2+P)*F$	RUU
Multiplication	$((A*B)+P)*F$	0000000
Division	$((A/B)+P)*F$	d if dE
Max of A or B	$((AB-Hi)+P)*F$	H if Ab
Min of A or B	$((AB-Lo)+P)*F$	Lo-Ab
Draw	$((A/B)-1)*F$	drRUU
Weighted avg.	$((B-A)*F)+A$	00 RUU
Ratio	$(A/B)*F$	rRt 0
Ratio 2	$((B-A)/A)+P)*F$	rRt 002
Concentration	$(A/(A+B))*F$	ConcEn
Total Addition	$(tA+tB+P)*F$	5000 t
G. Tot. Addition	$(GtA+GtB+P)*F$	500000t
Total Difference	$(tA-tB+P)*F$	d if t
G. Tot. Difference	$(GtA-GtB+P)*F$	d if 0t
Total Ratio	$(tA/tB)*F$	tRt 0
Total Ratio 2	$((tB-tA)/tA)*F$	t-rRt2
Total Percent	$(tA/(tA+tB))*100$	t Pct

Note: The F constant can be any value from 0.001 to 999.999. If the value is less than 1, it will have the same effect as a divider. For example, the average could also be derived by using $(A+B)*F$, where $F = 0.500$.

- | | |
|---|---|
| Sequence of Operations for Input Programming | <ol style="list-style-type: none"> 1. Select Input for A and B 2. Set up the rate, total, and grand total engineering units for channels A & B, and units for math channel C 3. Set up rate, total, and grand total decimal points for channels A & B, and decimal point for math channel C 4. Program channel A & B rate parameters 5. Program channel A & B total and reset parameters 6. Set up display lines 1 & 2 and display intensity 7. Select the transfer function for A & B (e.g. Linear) 8. Select Math function for Channel C 9. Program constants for Factor (F) and Adder (P). 10. Program cutoff values for A and B |
|---|---|

Low Voltage Mag Pickup	Sensitivity: 40 mVp-p to 8Vp-p
Minimum Input Frequency	0.001 Hz Minimum frequency is dependent on high gate setting.
Maximum Input Frequency	30,000 Hz (10,000 for low voltage mag pickup)
Input Impedance	Pulse input: Greater than 300 kΩ @ 1 kHz. Open collector/switch input: 4.7 kΩ pull-up to 5 V.
Accuracy	±0.03% of calibrated span ±1 count
Temperature Drift	Rate display is not affected by changes in temperature.

Multi-Point Linearization	2 to 32 points for channel A and B
Low-Flow Cutoff	0-999999 (0 disables cutoff function)
Decimal Point	Up to five decimal places or none: <i>dddddd, ddddd, dddd, ddd, dd, or dddddd</i>
Calibration	May be calibrated using K-factor, internal calibration, or by applying an external calibration signal.
K-Factor	Field programmable K-factor converts input pulses to rate in engineering units. May be programmed from 0.00001 to 999,999 pulses/unit.
Calibration Range	Input 1 signal may be set anywhere in the range of the meter; input 2 signal may be set anywhere above or below input 1 setting. Minimum input span between any two inputs is 10 Hz. An error message will appear if the input span is too small.
Filter	Programmable contact de-bounce filter: 40 to 999 Hz maximum input frequency allowed with low speed filter.
Time Base	Second, minute, hour, or day
Gate	Low gate: 0.1-99.9 seconds High gate: 2.0-999.9 seconds
F4 Digital Input Contacts	3.3 VDC on contact. Connect normally open contacts across F4 to COM.
F4 Digital Input Logic Levels	Logic High: 3 to 5 VDC Logic Low: 0 to 1.25 VDC

Dual Rate/Totalizer

Rate Display Indication	-99999 to 999999, lead zero blanking.
Total Display & Total Overflow	0 to 999,999; automatic lead zero blanking. Up to 999,999,999 with total-overflow feature. "OF" is displayed to the left of total overflow and ▲ LED is illuminated.
Total Decimal Points	Up to five decimal places or none: <i>dddddd, ddddd, dddd, ddd, dd, or dddddd</i> Total decimal point is independent of rate decimal point. Channel A and B decimal points programmed independently.
Dual Totalizer	Calculates total for channels A and B based on rate and field programmable multiplier to display total in engineering units. Time base must be selected according to the time units in which the rate is displayed. Channel A and B totalizer parameters programmed independently.
Totalizer Rollover	Totalizer rolls over when display exceeds 999,999,999. Relay status reflects display.
Total Overflow Override	Program total A or B total reset for automatic with 0.1 second delay and set point 1 for 999,999

Totalizer Alarm Presets	Up to eight, user selectable under setup menu. Any set point can be assigned to channel A or B total or grand total (or C) and may be programmed anywhere in the range of the meter for total alarm indication.
Total & Grand Total Reset	Via front panel button, external contact closure on digital inputs, automatically via user selectable preset value and time delay, or through serial communications. Channel A and B total and grand total reset parameters programmed independently.
Total Reset Password	Total and grand total passwords may be entered to prevent resetting the totals or grand totals from the front panel.
Non-Resettable Total	The grand totals can be programmed as non-resettable totals by entering the password "050873". Both channels are set to non-resettable when this password is entered.  <i>Once the Grand Totals have been programmed as "non-resettable" the feature cannot be disabled.</i>
Programmable Delay On Release	0.1 and 999.9 seconds; applied to the first relay assigned to total or grand total. If the meter is programmed to reset total to zero automatically when the preset is reached, then a delay will occur before the total is reset.
Relays	
Rating	2 or 4 SPDT (Form C) internal and/or 4 SPST (Form A) external; rated 3 A @ 30 VDC and 125/250 VAC resistive load; 1/14 HP (≈ 50 W) @ 125/250 VAC for inductive loads
Noise Suppression	Noise suppression is recommended for each relay contact switching inductive loads; see page 19 for details.
Relay Assignment	Relays may be assigned to channel A or B rate, total, or grand total; channel C; or Modbus control.
Deadband	0-100% of span, user programmable
High Or Low Alarm	User may program any alarm for high or low trip point. Unused alarm LEDs and relays may be disabled (turn off).
Relay Operation	Automatic (non-latching) Latching (requires manual acknowledge) Sampling (based on time) Pump alternation control (2 to 4 relays) Off (disable unused relays and enable Interlock feature) Manual on/off control mode
Time Delay	0 to 999.9 seconds, on & off relay time delays Programmable and independent for each relay
Auto Initialization	When power is applied to the meter, relays will reflect the state of the input to the meter.

Fail-Safe Operation	Programmable and independent for each relay. <i>Note: Relay coil is energized in non-alarm condition. In case of power failure, relay will go to alarm state.</i>
Relay Reset	User selectable via front panel buttons, digital inputs, or PC <ol style="list-style-type: none"> Automatic reset only (non-latching), when the input passes the reset point. Automatic + manual reset at any time (non-latching) Manual reset only, at any time (latching) Manual reset only after alarm condition has cleared (L) <i>Note: Front panel button or digital input may be assigned to acknowledge relays programmed for manual reset.</i>

Isolated 4-20 mA Transmitter Output

Output Source	Input channels A or B, rate, total, or grand total; channel C; max or min for channel A or B; highest or lowest max or min of A and B; set points 1-8; Modbus input; or manual control mode		
Scaling Range	1.000 to 23.000 mA for any display range		
Calibration	Factory calibrated: 4.000 to 20.000 = 4-20 mA output		
Analog Out Programming	23.000 mA maximum for all parameters: Overrange, underrange, max, min, and break		
Accuracy	± 0.1% of span ± 0.004 mA		
Temperature Drift	0.4 µA/°C max from 0 to 65°C ambient, 0.8 µA/°C max from -40 to 0°C ambient <i>Note: Analog output drift is separate from input drift.</i>		
Isolated Transmitter Power Supply	Terminals I+ & R: 24 VDC ± 10%. May be used to power the 4-20 mA output or other devices. Refer to Figure 3 on page 14 and Figure 19 on page 20. All models @ 25 mA max.		
External Loop Power Supply	35 VDC maximum		
Output Loop Resistance	Power supply	Minimum	Maximum
	24 VDC	10 Ω	700 Ω
	35 VDC (external)	100 Ω	1200 Ω

Digital Inputs & Outputs

Channels	4 digital inputs & 4 digital outputs per module
Digital Input Logic High	3 to 5 VDC

Digital Input Logic Low	0 to 1.25 VDC
Digital Output Logic High	3.1 to 3.3 VDC
Digital Output Logic Low	0 to 0.4 VDC
Source Current	10 mA maximum output current
Sink Current	1.5 mA minimum input current
+5 V Terminal	To be used as pull-up for digital inputs only. Connect normally open pushbuttons across +5 V & DI 1-4.  DO NOT use +5 V terminal (pin 1) to power external devices.
Function Assignment	The on-board digital inputs (1-4) are designed to mimic the behavior of the front panel buttons (Menu, F1, F2, & F3). If you wish to change their behavior, re-assign F1-F3 to the desired function, then change the corresponding digital input to match.

Serial Communications

Slave Id	1 – 247 (Meter address)
Compatibility	EIA-485
Connectors	Removable screw terminal connector
Max Distance	3,937' (1,200 m) max
Status Indication	Separate LEDs for Power (P), Transmit (TX), and Receive (RX)
Baud Rate	300 – 19,200 bps
Transmit Time Delay	Programmable between 0 and 199 ms
Data	8 bit (1 start bit, 1 or 2 stop bits)
Parity	Even, Odd, or None with 1 or 2 stop bits
Byte-To-Byte Timeout	0.01 – 2.54 second
Turn Around Delay	Less than 2 ms (fixed)

Note: Refer to the PROVU® Modbus Register Tables located at www.predig.com for details.

MeterView Pro

System Requirements	Microsoft® Windows® XP/Vista/7/8/10
Communications	USB 2.0 (Standard USB A to Micro USB B)
Configuration	Configure device settings one at a time

Product Ratings and Approvals;

FM	Enclosure: Type 4X; IP66 Class I, Division 1, Groups B, C, D Class II, Division 1, Groups E, F, G Class III, Division 1, T5/T6 Class I, Zone 1, AEx d, IIC Gb T5/T6 Zone 21, AEx tb IIIC T90°C; Ta -40°C to +65°C T6 Ta = -40°C to +60°C; T5 Ta = -40°C to +65°C Certificate Number: 3047283
CSA	Class I, Division 1, Groups B, C, D Class II, Division 1, Groups E, F, G Class III, Division 1 Class I Zone 1 Ex d IIC Zone 21 Ex tb IIIC T90°C -40°C < Tamb. < +60° C; Temperature Code T6 -40°C < Tamb. < +65° C; Temperature Code T5 Enclosure Type 4X & IP66 Certificate Number: 2531731
ATEX	 II 2 G D Ex d IIC T* Gb Ex tb IIIC T90°C Db IP68 Ta = -40°C to +*°C *T6 = -40°C to +60°C *T5 = -40°C to +65°C Certificate number: Sira 12ATEX1182
IECEX	Ex d IIC T* Gb Ex tb IIIC T90°C Db IP68 Ta = -40°C to +*°C *T6 = -40°C to +60°C *T5 = -40°C to +65°C Certificate Number: IECEX SIR 12.0073

Special Conditions for Safe Use:

Use suitably certified and dimensioned cable entry device and/or plug. The equipment shall be installed such that the supply cable is protected from mechanical damage. The cable shall not be subjected to tension or torque. If the cable is to be terminated within an explosive atmosphere, then appropriate protection of the free end of the cable shall be provided. Cable must be suitable for 90°C.

Year of Construction

This information is contained within the serial number with the first four digits representing the year and month in the YYMM format.

For European Community: The ProtEX-MAX must be installed in accordance with the ATEX directive 94/9/EC, and the product certificate Sira 12ATEX1182.

Compliance Information

Safety

UL & c-UL Listed	USA & Canada UL 508 Industrial Control Equipment
UL File Number	E160849
Front Panel	UL Type 4X, NEMA 4X, IP65; panel gasket provided
Low Voltage Directive	EN 61010-1:2010 Safety requirements for measurement, control, and laboratory use

Electromagnetic Compatibility

Emissions	EN 55022:2010 Class A ITE emissions requirements
Radiated Emissions	Class A
AC Mains Conducted Emissions	Class A
Immunity	EN 61326-1:2013 Measurement, control, and laboratory equipment EN 61000-6-2:2005 EMC heavy industrial generic immunity standard
RFI - Amplitude Modulated	80 -1000 MHz 10 V/m 80% AM (1 kHz) 1.4 - 2.0 GHz 3 V/m 80% AM (1 kHz) 2.0 - 2.7 GHz 1 V/m 80% AM (1 kHz)
Electrical Fast Transients	±2kV AC mains, ±1kV other
Electrostatic Discharge	±4kV contact, ±8kV air
RFI - Conducted	10V, 0.15-80 MHz, 1kHz 80% AM
AC Surge	±2kV Common, ±1kV Differential
Surge	1KV (CM)
Power-Frequency Magnetic Field	30 A/m 70%V for 0.5 period
Voltage Dips	40%V for 5 & 50 periods 70%V for 25 periods
Voltage Interruptions	<5%V for 250 periods

Note:

Testing was conducted on PD8-6363 series meters installed through the covers of grounded metal enclosures with cable shields grounded at the point of entry representing installations designed to optimize EMC performance.

Declaration of Conformity available at www.predig.com

Safety Information



WARNINGS

- Read complete instructions prior to installation and operation of the instrument.
- Installation and service should be performed only by trained service personnel. Service requiring replacement of internal sub-components must be performed at the factory.
- Disconnect from supply before opening enclosure. Keep cover tight while circuits are alive. Conduit seals must be installed within 18" (450mm) of the enclosure or within 2" (50mm) for Zone installations.
- Verify that the operating atmosphere of the instrument is consistent with the appropriate hazardous locations certifications.
- If the instrument is installed in a high voltage environment and a fault or installation error occurs, high voltage may be present on any lead
- Read all product labels completely and follow all instructions and requirements listed on the labels for installation or service.

Installation

Install in accordance with applicable local and national regulations (e.g. NEC).

For Installation in USA: The ProtEX-MAX must be installed in accordance with the National Electrical Code (NEC) NFPA 70.

For Installation in Canada: The ProtEX-MAX must be installed in accordance with the Canadian Electrical Code CSA 22.1. All power supplies below 36 V and input circuits must be derived from a CSA Approved Class 2 source.

For European Community: The ProtEX-MAX must be installed in accordance with the ATEX directive 94/9/EC and the product certificate Sira 12ATEX1182.



WARNING

Disconnect from supply before opening enclosure. Keep cover tight while circuits are alive. Conduit seals must be installed within 18" (450mm) of the enclosure or within 2" (50mm) for Zone installations.

Wiring connectors are accessed by opening the enclosure. To access electrical connectors, remove the 2 captive screws and then remove the electronics module. Connectors are on the rear of the electronics module.

Unpacking

Remove the instrument from packing box. Inspect the packaging and contents for damage. Report damages, if any, to the carrier.

If any part is missing or the instrument malfunctions, please contact your supplier or the factory for assistance.

Pre-Installed Conduit/Stopping Plug

The PD8-6000 is supplied with two pre-installed conduit plugs for installations that do not require the use of all conduit entries. The conduit/stopping plugs include an internal 12mm hexagonal socket recess for removal. The pre-installed plugs and their installation are included in the hazardous area approvals for the PD8 Series enclosure.

 WARNING	In hazardous areas, conduit and conduit/stopping plugs require the application of non-setting (solvent free) thread sealant. It is critical that all relevant hazardous area guidelines be followed for the installation or replacement of conduit or plugs.
---	--

Mounting

The ProtEX-MAX has four slotted mounting flanges that should be used for pipe mounting or wall mounting. Refer to *Mounting Dimensions*, page 64 for details.

 WARNING	Do not attempt to loosen or remove flange bolts while the instrument is in service.
---	---

Cover Jam Screw

The cover jam screw should be properly installed once the instrument has been wired and tested in a safe environment. The cover jam screw is intended to prevent the removal of the instrument cover in a flameproof environment without the use of tools. Using a M2 hex wrench, turn the screw clockwise until the screw contacts the aluminum enclosure. Turn the screw an additional 1/4 to 1/2 turn to secure the cover. Caution: Excess torque may damage the threads and/or wrench.

Transmitter Supply Voltage Selection (P+, P-)

All meters, including models equipped with the 12-24 VDC power option, are shipped from the factory configured to provide 24 VDC power for the transmitter or sensor.

If the transmitter requires 5 or 10 VDC excitation, the internal jumper J4 must be configured accordingly.

To access the voltage selection jumper:

1. Remove all the wiring connectors.
2. Unscrew the back cover.
3. Slide out the back cover by about 1 inch.
4. Configure the J4 jumper, located behind the input signal connector, for the desired excitation voltage as shown.

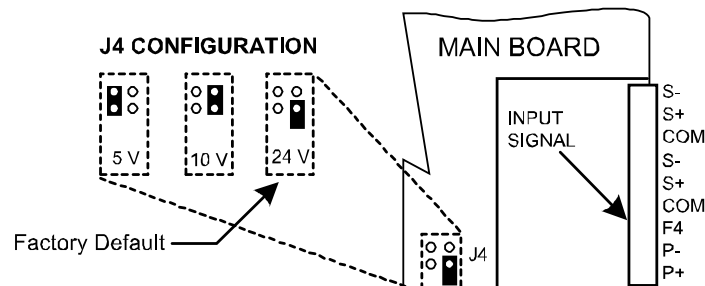



Figure 1. Transmitter Supply Voltage Selection

Connections



WARNINGS

- **Static electricity can damage sensitive components.**
- **Observe safe handling precautions for static-sensitive components.**
- **Use proper grounding procedures/codes.**
- **If the instrument is installed in a high voltage environment and a fault or installation error occurs, high voltage may be present on any lead or terminal.**
- **Follow all fusing and wiring precautions requirements for the instrument integrated to the PD8 Series model number being connected.**

To access the connectors, remove the enclosure cover and unscrew the two captive screws that fasten the electronics module. Signal connections are made to de-pluggable connectors on the back of the electronics module.

Some connectors may be provided already connected. These connections are required for proper operation of the ProtEX-MAX, and should not be removed unless instructed to by this manual.

Wires marked as being used for testing purposes should be removed.

Grounding connections are made to the two ground screws provided on the base – one internal and one external.

After all connections have been completed and verified, apply power to the unit.

Required & Factory Wired Connection

The ProtEX-MAX comes with a pre-wired connection. This connection is detailed below, and must be maintained in order for the instrument to function properly.



WARNING

Observe all safety regulations. Electrical wiring should be performed in accordance with all agency requirements and applicable national, state, and local codes to prevent damage to the meter and ensure personnel safety.

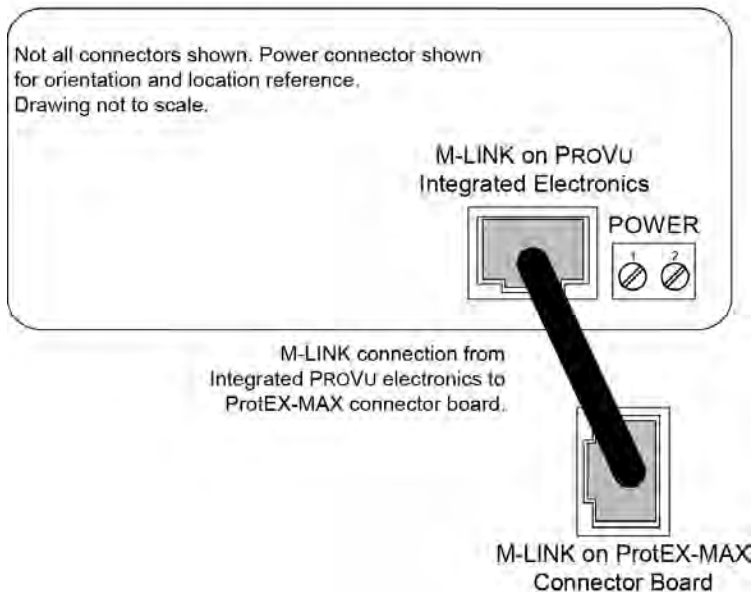



Figure 2: Integrated ProVu Required Connections

Connectors Labeling

The connectors' label, affixed to the meter, shows the location of all connectors available with requested configuration.



Warning! *Do not connect any equipment other than Precision Digital's expansion modules, cables, or meters to the RJ45 M-LINK connector. Otherwise damage will occur to the equipment and the meter.*

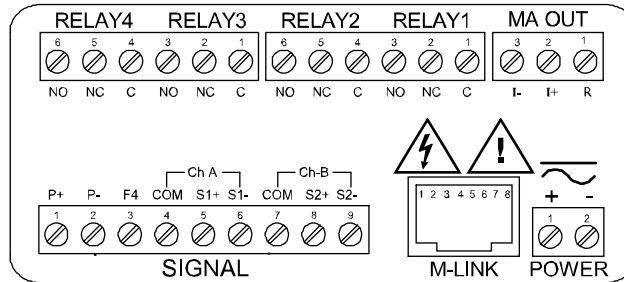
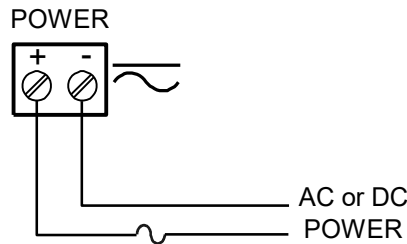

Figure 3. Connector Labeling for Fully Loaded PD8-6363

Power Connections

Power connections are made to a two-terminal connector labeled POWER on Figure 3. The meter will operate regardless of DC polarity connection. The + and - symbols are only a suggested wiring convention.



Required External Fuse:
5 A max, 250 V Slow Blow

Figure 4. Power Connections

Signal Connections

Signal connections are made to a nine-terminal connector labeled SIGNAL on Figure 3. The COM (common) terminals are the return for certain input signals. The two COM terminals connect to the same common return, and are not isolated.

The following figures show examples of signal connections.

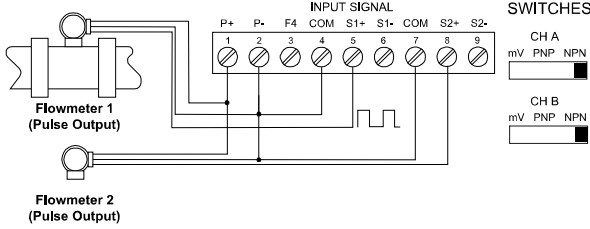

Figure 5: Flowmeter Powered by Internal Power Supply

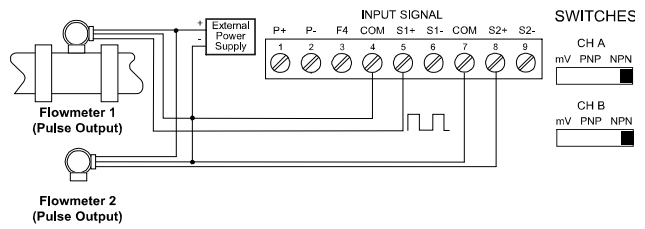

Figure 6: Flowmeter Powered by External Supply

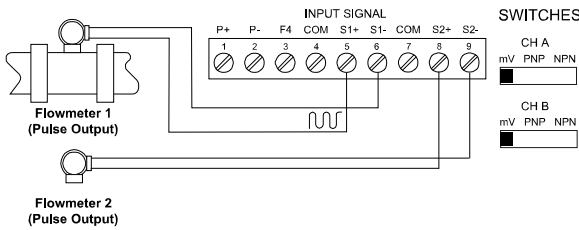

Figure 7: Self-Powered Magnetic Pickup Coil Flowmeter

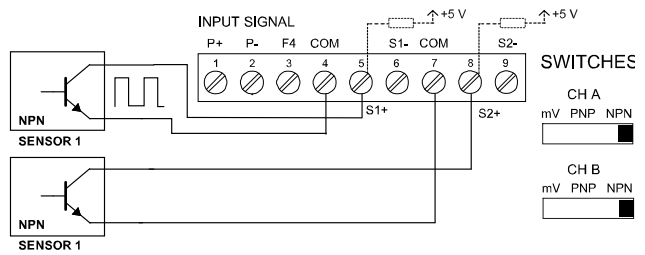

Figure 8: NPN open Collector Input

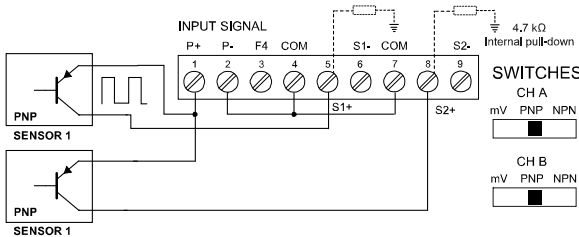

Figure 9: PNP Sensor Powered by Internal Supply

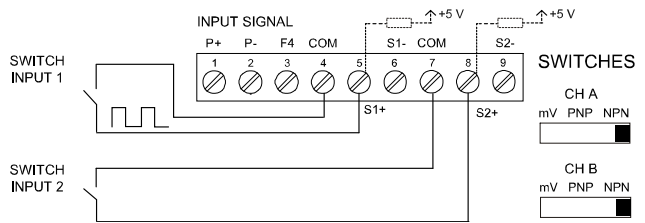

Figure 10: Switch Input Connections

Configure Input Type and Level Switches

Channel A and B each have an internal input type configuration switch. These switches must be set to the correct input type and level. Each switch can be set for mV, PNP, or NPN. For details on what input type to select, see Signal Connections starting on page 15.

To configure the meter for 12 VDC power:

1. Remove all the connectors.
2. Unscrew the back cover.
3. Remove the back cover.
4. Configure the input selection switches for channel A and B, located behind the input connector on the far left, as needed.
5. Slide rear cover back onto the meter.
6. Screw the back cover on. Do not over tighten.
7. Replace all connectors.

Serial Communications Connections

The ProtEX-MAX has a 5 position terminal block for connecting RS-485 serial devices.

Figure 11 details the wiring connections from the ProtEX-MAX to an RS-485 serial converter (such as the PDA7485 or PDA8485) for a four-wire network.

ProtEX-MAX to RS-485 Serial Converter Connections	
RS-485 Serial Converter	ProtEX-MAX RS- 485 Connections
$\underline{\text{DI}}$	$\underline{\text{DI}}$
$\overline{\text{DO}}$	$\overline{\text{DI}}$
DO	DI
$\overline{\text{DI}}$	$\overline{\text{DO}}$
DI	DO

Figure 11: ProtEX-MAX Connections to a Serial Converter

The ProtEX-MAX has three diagnostic LEDs: a Power (P) LED to show when the module is powered properly, a Transmit Data (TX) LED to show when the module is being transmitted to by the PC side, and a Receive Data (RX) LED to show when the module is sending data to a receiving device.

The following diagrams detail how to connect the RS-485 serial communications from the ProtEX-MAX to a RS-485/RS-232 serial converter (PDA7485) in four wire and two wire configurations.

Three Wire Connections

In order to wire the 5 pins for use as a 3-wire half-duplex RS-485 connection, it is necessary to create a jumper connection between DI – DO and $\overline{\text{DI}}$ – $\overline{\text{DO}}$ as shown below.

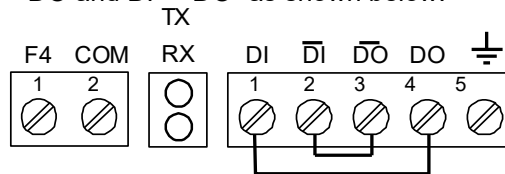

Figure 12. Three-Wire RS485 Connection

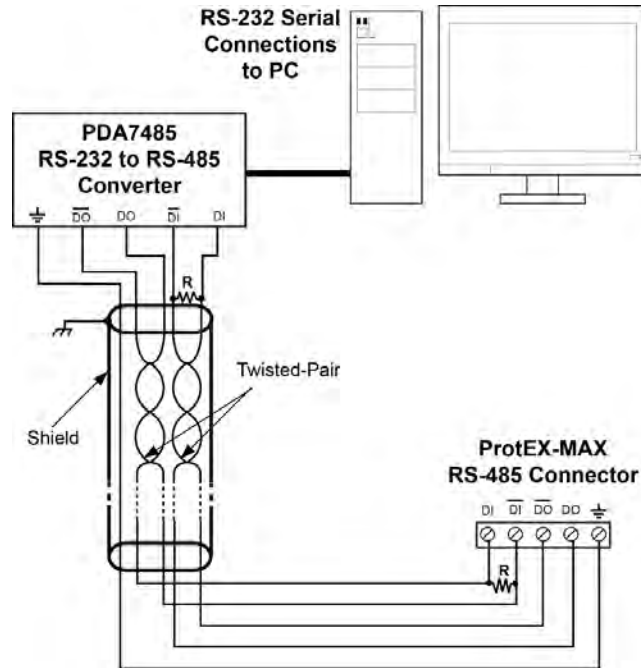



Figure 13: RS-485 Wiring

Notes:

1. Termination resistors are optional and values depend on the cable length and characteristic impedance. Consult the cable manufacturer for recommendations.
2. Refer to RS-232 to RS-485 Converter documentation for further details.
3. Use shielded cable, twisted-pairs plus ground. Connect ground shield only at one location.

 WARNING	<p>Observe all safety regulations. Electrical wiring should be performed in accordance with all agency requirements and applicable national, state, and local codes to prevent damage to the meter and ensure personnel safety.</p>
---	---

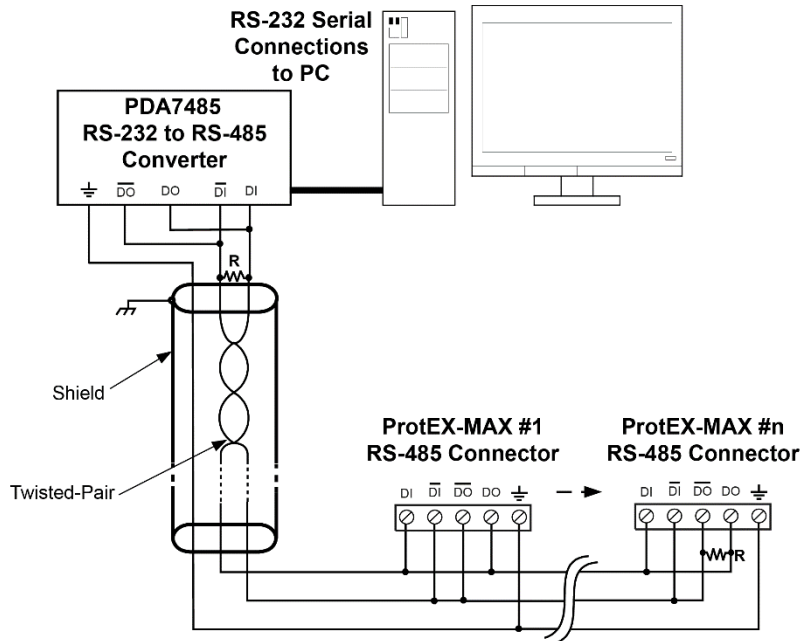



Figure 14: RS-485 Two-Wire Multi-Drop Wiring

Notes:

1. Termination resistors are optional and values depend on the cable length and characteristic impedance. Consult the cable manufacturer for recommendations.
2. Refer to RS-232 to RS-485 Converter documentation for further details.
3. Use shielded cable, twisted-pair plus ground. Connect ground shield only at one location.

 WARNING	Observe all safety regulations. Electrical wiring should be performed in accordance with all agency requirements and applicable national, state, and local codes to prevent damage to the meter and ensure personnel safety.
---	--

When using more than one instrument in a multi-drop or multi-point mode, each meter must be provided with its own unique address.

Using PROVu Serial Adapters

 NOTICE	PROVu expansion modules and serial adapters are not included in the hazardous area approvals of the ProtEX-MAX. The PDA1232 may be used only while the ProtEX-MAX is in a safe area, and will disable some features while installed.
--	--

PROVu expansion modules and serial adapters are not recommended for use with the ProtEX-MAX. It is recommended that any serial protocol conversion required on the RS-485 communications connection be performed using a PDA7485 RS-232 to RS-485 or PDA8485 USB to RS-485 serial converter located in a safe area.

Relay Connections

Relay connections are made to two six-terminal connectors labeled RELAY1 – RELAY4 on Figure 3. Each relay's C terminal is common only to the normally open (NO) and normally closed (NC) contacts of the corresponding relay. The relays' C terminals should not be confused with the COM (common) terminal of the INPUT SIGNAL connector.

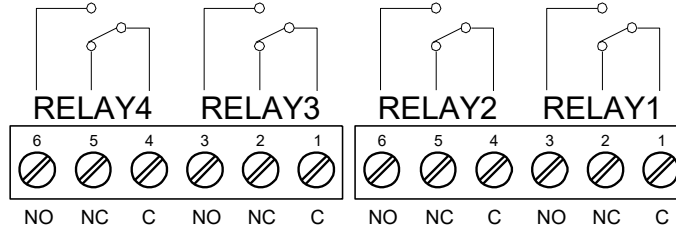

Figure 15. Relay Connections

Switching Inductive Loads

The use of suppressors (snubbers) is strongly recommended when switching inductive loads to prevent disrupting the microprocessor's operation. The suppressors also prolong the life of the relay contacts. Suppression can be obtained with resistor-capacitor (RC) networks assembled by the user or purchased as complete assemblies. Refer to the following circuits for RC network assembly and installation:

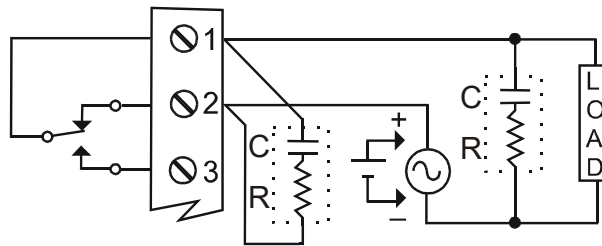

Figure 16. AC and DC Loads Protection

Choose R and C as follows:

R: 0.5 to 1 Ω for each volt across the contacts

C: 0.5 to 1 μF for each amp through closed contacts

Notes:

1. Use capacitors rated for 250 VAC.
2. RC networks may affect load release time of solenoid loads. Check to confirm proper operation.
3. Install the RC network at the meter's relay screw terminals. An RC network may also be installed across the load. Experiment for best results.

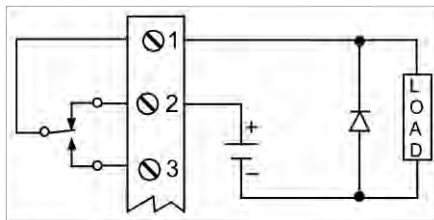

Use a diode with a reverse breakdown voltage two to three times the circuit voltage and forward current at least as large as the load current.

Figure 17. Low Voltage DC Loads Protection

RC Networks Available from Precision Digital

RC networks are available from Precision Digital and should be applied to each relay contact switching an inductive load. Part number: PDX6901.

Note: Relays are de-rated to 1/14th HP (50 watts) with an inductive load.

F4 Digital Input Connections

A digital input, F4, is standard on the meter. This digital input connected with a normally open closure across F4 and COM, or with an active low signal applied to F4.

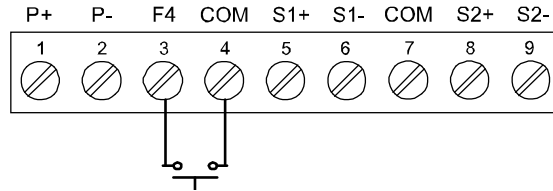

Figure 18. F4 Digital Input Connections

4-20 mA Output Connections

Connections for the 4-20 mA transmitter output are made to the connector terminals labeled MA OUT. The 4-20 mA output may be powered internally or from an external power supply.

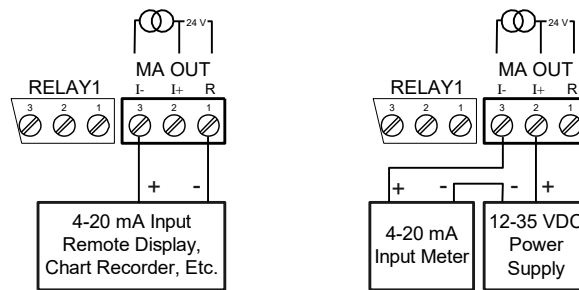

Figure 19. 4-20 mA Output Connections

Analog Output Transmitter Power Supply

The internal 24 VDC power supply powering the analog output may be used to power other devices, if the analog output is not used. The I+ terminal is the +24 V and the R terminal is the return.

Interlock Relay Feature

As the name implies, the interlock relay feature reassigns one, or more, alarm/control relays for use as interlock relay(s). Interlock contact(s) are wired to digital input(s) and trigger the interlock relay. This feature is enabled by configuring the relay, and relative digital input(s) (see page 45). In one example, dry interlock contacts are connected in series to one digital input which will be used to force on (energize) the assigned interlock power relay when all interlock contacts are closed (safe). The interlock relay front panel LED flashes when locked out. The interlock relay would be wired in-series with the load (N/O contact). See below.

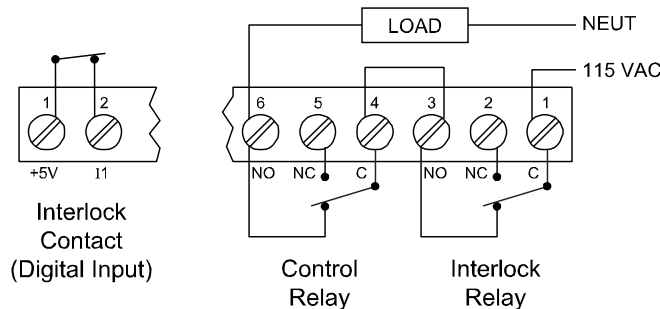

Figure 20. Interlock Connections

Digital I/O Connections

The ProtEX-MAX has a 10 position terminal block for connecting digital inputs and outputs.

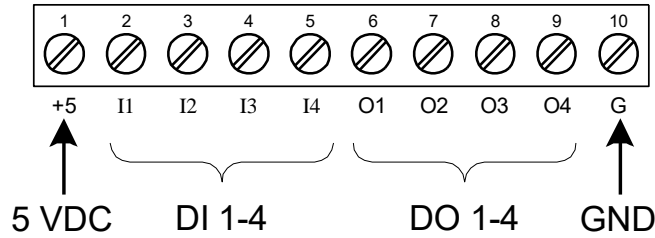

Figure 21: Digital I/O Connections

 NOTICE	<p>The onboard digital inputs (1-4) are configured at the factory to function identically to the front panel pushbuttons (Menu, F1, F2, & F3) in order to work with the SafeTouch buttons. Changing the programming of the digital inputs will affect the function of the SafeTouch buttons.</p> <p>If you wish to change the behavior of the digital inputs, re-assign F1-F3 to the desired function, then change the corresponding digital input to match.</p>
 WARNING	<p>Observe all safety regulations. Electrical wiring should be performed in accordance with all agency requirements and applicable national, state, and local codes to prevent damage to the meter and ensure personnel safety.</p>

External Switch Contacts

The ProtEX-MAX includes 4 digital inputs. These digital inputs are preconfigured at the factory to function as external contacts to duplicate the front button functions of the instrument. The factory configuration uses the following corresponding digital input terminals for external switch contacts.

Digital Input Connection	Factory Default Function
I1	MENU
I2	RIGHT arrow
I3	UP arrow
I4	ENTER arrow

See Digital Inputs & Outputs in the Specification on page 8 for details on the digital inputs.

 NOTICE	<p>The digital inputs are configured at the factory to function identically to the front panel pushbuttons in order to work with the SafeTouch buttons. Changing the programming of the digital inputs will affect the function of the SafeTouch buttons.</p>
-------------------	---

Setup and Programming

- The meter has been factory calibrated to read input frequency in Hz (pulses/sec). The calibration equipment is traceable to NIST standards.
- Use the *K-Factor* menu to match the rate/totalizer with a flowmeter's k-factor (pulse/unit of measure).
- Or use the *Scale* menu to scale the pulse input (pulse/sec) without a signal source.
- **Or use *Cal* menu to calibrate the rate/totalizer using a signal source.**

Overview

There are no jumpers to set for the meter input selection.

Setup and programming may be done through the infrared through-glass SafeTouch buttons, or using the mechanical buttons when uncovered. There is a slide switch located on the connector board. This is used to enable or disable SafeTouch Buttons.

After power and input signal connections have been completed and verified, apply power to the meter.

SafeTouch® Buttons

The ProtEX-MAX is equipped with four sensors that operate as through-glass buttons so that it can be programmed and operated without removing the cover (and exposing the electronics) in a hazardous area.

These buttons can be disabled for security by selecting DISABLE on the switch labeled NO-CONTACT BUTTONS located on the connector board.

To actuate a button, press one finger to the glass directly over the marked button area. Then retract finger more than three inches from the glass before pressing the next button. When the cover is removed, the four mechanical buttons located next to the sensors are used. The sensors are disabled when a mechanical button is pressed and will automatically be re-enabled after 60 seconds of inactivity.

The SafeTouch Buttons are designed to filter normal levels of ambient interference and to protect against false triggering, however, it is recommended that the SafeTouch Buttons be disabled (slide switch to LOCK) if there is an infrared interference source in line-of-sight to the display.

The SafeTouch Buttons are configured by default to duplicate the function of the front panel mechanical pushbuttons associated with the integrated meter. The symbols by each SafeTouch button correspond to a mechanical button as shown in the table on the next page.

SafeTouch Button Tips:









- To the extent possible, install the display facing away from sunlight, windows, reflective objects and any sources of infrared interference.
- Keep the glass window clean.
- Tighten the cover securely.
- Use a password to prevent tampering.



Take caution when cleaning the window glass as it may result in unintentional SafeTouch button events. Only clean the ProtEX-MAX when the system is safely shut down, and inspect the ProtEX-MAX for proper configuration prior to system restart.

Front Buttons and Status LED Indicators



Button Symbol	Description	LED	Status
 OR 	Menu	1-8	Alarm 1-8 indicator
 OR 	Right arrow/F1	1-8 M	Flashing: Relay in manual control mode
 OR 	Up arrow/F2	A B C	Channel displayed
 OR 	Enter/F3	1-4	Flashing: Relay interlock switch open
Notes: F4 is a digital input.		Note: LEDs for relays in manual mode flash with the "M" LED every 10 seconds.	

- Press the Menu button to enter or exit the Programming Mode at any time.
- Press the Right arrow button to move to the next digit during digit or decimal point programming.
- Press or hold the Up arrow button to scroll through the menus, decimal point, or to increment the value of a digit.
- Press the Enter button to access a menu or to accept a setting.
- Press and hold the Menu button for three seconds to access the advanced features of the meter.

MeterView® Pro Software

The meter can also be programmed using the PC-based MeterView Pro software included with the meter. This software can be installed on any Microsoft® Windows® (XP/Vista/7/8/10) computer by connecting the meter's onboard USB. The meter is powered by the USB connection, so there is no need to wire anything prior to programming the meter, though USB is intended only for meter configuration.

MeterView Pro Installation

1. Connect one end of the provided USB cable to the internal electronics module and the other end to the computer. The computer will automatically install the driver software it needs to talk to the meter. **Only one meter may be connected at a time. Attaching multiple meters will cause a conflict with the meter software.**

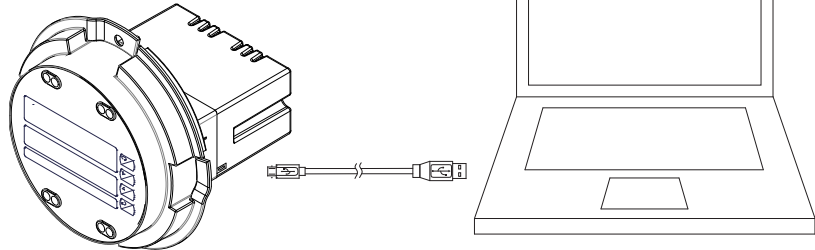

2. Once the driver is installed, an AutoPlay dialog should appear for the drive "MAINSTAL." Click "Open folder to view files." If the computer does not display an AutoPlay dialog for the drive "MAINSTAL," you should open My Computer and double-click on the drive labeled "MAINSTAL."
3. Double-click on the file named "MAStart." The program will open a few windows and install two programs on your computer. Simply follow the onscreen instructions until you see one of the dialogs below. If you receive a "User Account Control" warning, click "Yes."
4. If there is an update available, click the "Update" button to install the new version. Otherwise, click "Configure" to begin programming your meter.



Note: If you decide to update your MeterView Pro software, once the installation has completed, you will be asked if you want to update the setup files located on the meter itself. This way, you will always have the most current version on the meter for future installs.



Warning!

Do not unplug the meter while the new installation files are being written to it. The meter will display $\mu r t E$ during the process and you will receive an onscreen notification once the process is complete.

Data logging for one meter at a time is available with MeterView Pro software. More advanced data acquisition may be accomplished by using any Modbus RTU compliant software. Additional information regarding configuration and monitoring of the meter using MeterView Pro software is available online. Go to www.predig.com/meterview-pro.

Display Functions & Messages

The following table shows the main menu functions and messages in the order they appear in the menu.

Display	Parameter	Action/Setting Description
SEtUP	Setup	Enter <i>Setup</i> menu
inPUt	Input	Enter <i>Input</i> selection menu
Ch-R*	Input	Set input operation for channel A (*or B)
toAL	Total	Enable/disable totalizer functions
YES	Yes	Enable totalizer functions
no	No	Disable totalizer functions
mode	Mode	Select dual-input operation mode
duAL	Dual	Set independent dual input mode
ud Ab	Up/Down AB	Set channel A total add/subtract based on the state of channel B
ud Ai	Up/Down AI	Set channel A total add/subtract based on the state of a digital input
ud Bi	Up/Down BI	Set channel B total add/subtract based on the state of a digital input
ud Bi	Up/Down ABI	Set channel A & B total add/subtract based on the state of a digital input for each
QuAd 1	Quadrature 1	Set type 1 quadrature operation
QuAd 2	Quadrature 2	Set type 2 quadrature operation
QuAd 4	Quadrature 4	Set type 4 quadrature operation
unitS	Unit	Select the display units/tags
Ch-R*	Rate unit	Set rate unit or tag for channel A (*or B)
Ch-C	Math unit	Set unit or tag for math channel C
toAL-R*	Total unit	Set total unit or tag for channel A (*or B)
toAL-R*	Grand total unit	Set grand total unit or tag for channel A (*or B)
dec Pt	Decimal point	Set decimal point

Display	Parameter	Action/Setting Description
Ch-R*	Decimal point	Set decimal point for channel A (*or B or C)
rate*	Rate	Set rate decimal point (*channel A and B only)
toAL*	Total	Set total decimal point (*channel A and B only)
toAL*	Grand total	Set grand total decimal point (*channel A and B only)
Prog	Program	Enter the <i>Program</i> menu
inCAL	Input calibration	Enter the <i>Input Calibration</i> menu
Ch-A	Channel A	Enter channel A input setup
FAct-A	K-factor A	Enter channel A k-factor
SCALE-A	Scale A	Enter the <i>Scale</i> menu for channel A
CAL-A	Calibrate A	Enter the <i>Calibration</i> menu for channel A
inp 1	Input 1	Calibrate input 1 signal or program input 1 value
dis 1	Display 1	Program display 1 value
inp 2	Input 2	Calibrate input 2 signal or program input 2 value (up to 32 points)
dis 2	Display 2	Program display 2 value (up to 32 points)
Error	Error	Error, calibration or scaling not successful, check signal or programmed value
Ch-b	Channel B	Enter channel B input setup
FAct-b	K-factor B	Enter channel B k-factor
SCALE-b	Scale B	Enter the <i>Scale</i> menu for channel B
CAL-b	Calibrate B	Enter the <i>Calibration</i> menu for channel B
SEtUP	Total setup	Enter the <i>Total Setup</i> menu
Ch-R*	Channel A	Setup the total for channel A (*or B)
tbASE	Time base	Program total time base

Display	Parameter	Action/Setting Description
Ƨ CF	Total conversion factor	Program total conversion factor
Ƨt CF	Grand total conversion factor	Program grand total conversion factor
ƧrESEt	Total reset	Program total reset mode: auto or manual
Ƨh-R*	Channel A	Set total reset modes for channel A (*or B)
Ƨ rSt	Total reset	Program total reset mode: auto or manual
Ƨt rSt	Grand total reset	Program grand total reset mode: auto or manual
Ƨ dLY	Time delay	Program automatic reset time delay
dSPLY	Display	Enter the Display menu
Ƨ nE 1	Display Line 2	Assign the upper display parameter
Ƨ nE 2	Display Line 2	Assign the lower display parameter
d Ƨh-A	Display Ch-A	Assign display to channel A
d Ƨh-b	Display Ch-B	Assign display to channel B
d Ƨh-Ƨ	Display Ch-C	Assign display to channel C (math)
d Rb	Display AB	Alternate display of channels A & B
d RƧ	Display AC	Alternate display of channels A & C
d bƧ	Display BC	Alternate display of channels B & C
d RbƧ	Display ABC	Alternate display of channels A, B, & C
d t-R	Display total A	Assign display to channel A total
d t-b	Display total B	Assign display to channel B total
d Ƨt-R	Display grand total A	Assign display to channel A grand total
d Ƨt-b	Display grand total B	Assign display to channel B grand total
d rƧ-R	Display rate and total A	Alternate display of channel A rate and total

Display	Parameter	Action/Setting Description
d rƧ-b	Display rate and total B	Alternate display of channel B rate and total
drƧt-R	Display rate and grand total A	Alternate display of channel A rate and grand total
drƧt-b	Display rate and grand total B	Alternate display of channel B rate and grand total
dSEt 1*	Display Set 1*	Displays relay 1(*through 8) set point.
d H r-R	Display high A	Display high value of channel A
d Lo-R	Display low A	Display low value of channel A
d HƧ-R	Display high/low A	Alternate between high/low value of channel A
d H r-b	Display high B	Display high value of channel B
d Lo-b	Display low B	Display low value of channel B
d HƧ-b	Display high/low B	Alternate between high/low value of channel B
d H r-Ƨ	Display high C	Display high value of channel C
d Lo-Ƨ	Display low C	Display low value of channel C
d HƧ-Ƨ	Display high/low C	Alternate between high/low value of channel C
d R-u	Display A and units/tags	Alternate display of channel A and the unit/tag
d b-u	Display B and units/tags	Alternate display of channel B and the unit/tag
d Ƨ-u	Display C and units/tags	Alternate display of channel C and the unit/tag
d tR-u	Display total A and total A units	Alternate display of channel A total and total units

Display	Parameter	Action/Setting Description
d tB-u	Display total B and total B units	Alternate display of channel B total and total units
d tAb	Display total A and B	Alternate display of channel A total and channel B total
d tAbC	Display total A, B, and sum of A and B	Alternate display of channel A total, channel B total, and sum of totals as channel C
m bus	Display Modbus	Display Modbus input register
d oFF	Display off	Display blank line 2
d un it	Display unit	Display line 1 channel units
d- In tY	Display intensity	Set display intensity level from 1 to 8
rELAY	Relay	Enter the <i>Relay</i> menu
ASS gn	Assignment	Assign relays to channels or Modbus
RS gn i*	Assign 1	Relay 1 (*through 8) assignment
Ch-A*	Channel A*	Assign relay to channel A (*or B or C)
rAtE*	Rate	Assign relay to rate (*channel A and B only)
totAL*	Total	Assign relay to total (*channel A and B only)
UtotAL*	Grand total	Assign relay to grand total (*channel A and B only)
m bus	Modbus	Assign relay to Modbus register
rLY i*	Relay 1	Relay 1 (*through 8) setup
Rct i	Action 1	Set relay 1 action
Ruto	Automatic	Set relay for automatic reset
SEt i	Set 1	Enter relay 1 set point
rSEt i	Reset 1	Enter relay 1 reset point
R-nRn	Auto-manual	Set relay for auto or manual reset any time
LRECH	Latching	Set relay for latching operation

Display	Parameter	Action/Setting Description
Lt-CLr	Latching-cleared	Set relay for latching operation with manual reset only after alarm condition has cleared
RLtErn	Alternate	Set relay for pump alternation control
SPn PL	Sample	Set relay for sample time trigger control
OFF	Off	Turn relay off
FR iLSF	Fail-safe	Enter <i>Fail-safe</i> menu
FLS i*	Fail-safe 1	Set relay 1 (*through 8) fail-safe operation
on	On	Enable fail-safe operation
oFF	Off	Disable fail-safe operation
dELAY	Delay	Enter relay <i>Time Delay</i> menu
dLY i*	Delay 1	Enter relay 1 (*through 8) time delay setup
On i	On 1	Set relay 1 On time delay
OFF i	Off 1	Set relay 1 Off time delay
Rout	Analog output	Enter the <i>Analog output</i> scaling menu
Rout i*	Aout Channel	Analog Output source channel (*1-3)
d iS 1	Display 1	Program display 1 value
Out i	Output 1	Program output 1 value (e.g. 4.000 mA)
d iS 2	Display 2	Program display 2 value
Out 2	Output 2	Program output 2 value (e.g. 20.000 mA)
rESEt	Reset	Press Enter to access the <i>Reset</i> menu
rSEt Hi	Reset high	Press Enter to reset max display
rSEt Lo	Reset low	Press Enter to reset min display
rSEt HL	Reset high & low	Press Enter to reset max & min displays
tot A	Reset total A	Press Enter to reset channel A total
tot B	Reset total B	Press Enter to reset channel B total
Utot A	Reset grand total A	Press Enter to reset channel A grand total

Display	Parameter	Action/Setting Description
GrAb	Reset grand total B	Press Enter to reset channel B grand total
tot Ab	Reset totals A and B	Press Enter to reset channels A and B totals
GrAb	Reset grand totals A and B	Press Enter to reset channels A and B grand totals
Control	Control	Enter Control menu
Auto	Automatic	Press Enter to set meter for automatic operation
Man	Manual	Press Enter to manually control relays or analog output operation
PRSS	Password	Enter the Password menu

Display	Parameter	Action/Setting Description
PRSS 1	Password 1	Set or enter Password 1
unLoc	Unlocked	Program password to lock meter
Locd	Locked	Enter password to unlock meter
PRSS 2	Password 2	Set or enter Password 2
PRSS 3	Password 3	Set or enter Password 3
totAL	Total reset password	Set or enter a total reset password
GrAbAL	Grand total reset password	Set or enter a grand total reset password
999999	Flashing	Overrange condition

Main Menu

The main menu consists of the most commonly used functions: *Reset, Control, Setup, and Password.*

- Press Menu button to enter Programming Mode then press the Up arrow button to scroll main menu.
- Press Menu, at any time, to exit and return to Run Mode. Changes made to settings prior to pressing Enter are not saved.
- Changes to the settings are saved to memory only after pressing Enter.
- The display moves to the next menu every time a setting is accepted by pressing Enter.

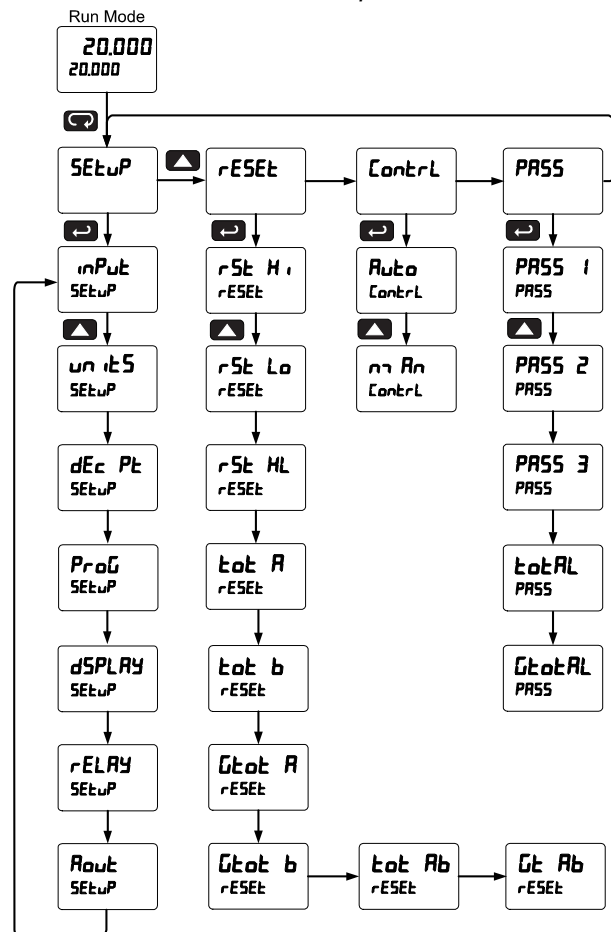

Setting Numeric Values

The numeric values are set using the Right and Up arrow buttons. Press Right arrow to select next digit and Up arrow to increment digit value. The digit being changed is displayed brighter than the rest. Press and hold Up to auto-increment the display value. If negative numbers are allowed, the first digit position will include a negative symbol (-) after the 9.

Press the Enter button, at any time, to accept a setting or Menu button to exit without saving changes.

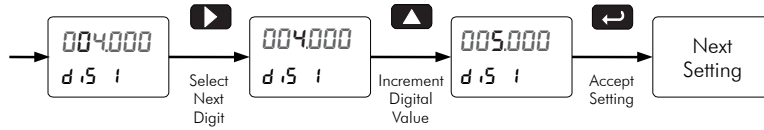

Setting Up the Meter (SEtUP)

The Setup menu is used to select:

1. Total enable/disable and channel A and B input modes
2. Units for A & B rate, total & grand total, and C
3. Decimal positions for A & B rate, total, and grand total, and C
4. Program the K-factor (or scale or calibrate) & total functions
5. Display parameters and intensity
6. Relay assignments and operation
7. 4-20 mA analog output scaling

Press the Menu button to exit at any time.

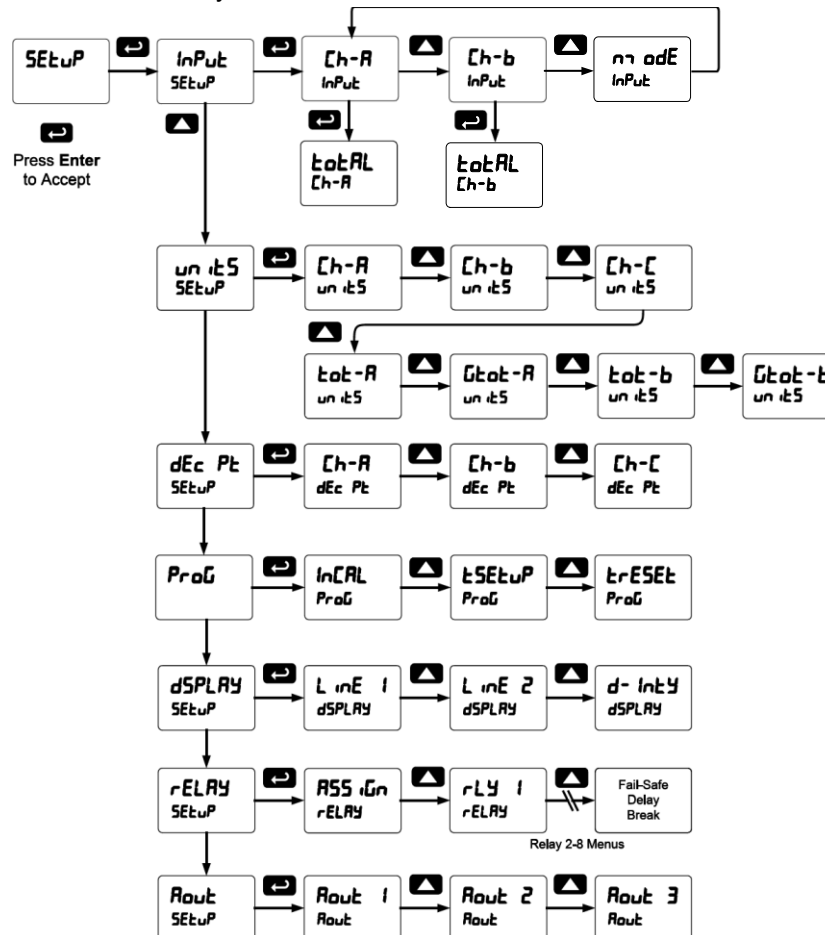

Setting the Input Signal (InPut)

There are two internal slide switches, located inside the rear meter housing to the left of the input connector, which must be configured according to the input levels and types. See Configure Input Type and Level Switches on page 15 for details.

Enter the Input menu to enable or disable the totalizer features.

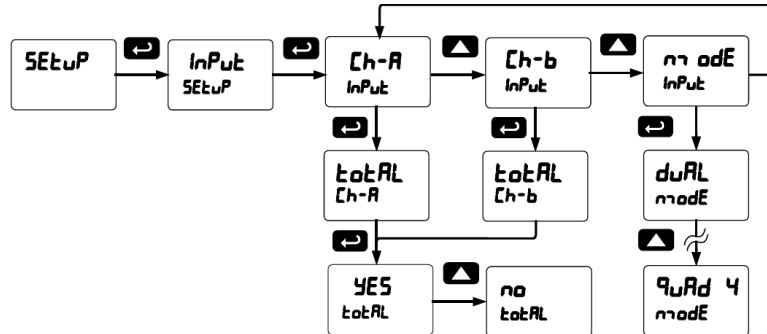

Setting the Totalizer Features (tOtAL)

To simply not display the total, select alternative display parameters in the display (dSPLY) menu.

Enable or disable the totalizer features by selecting “YES” or “no” after the input type has been set up. If the totalizer features are disabled, most totalizer features and functions are hidden from the menus.

Note: The totalizer continues working in the background.

Setting the Dual-Input Mode (modE)

The Mode menu is used to set the functions of the dual input and total. The inputs may be configured for independent one-directional total operation, bi-directional total count with the use of another input or a digital input, or for quadrature input modes.

Independent Dual Totalizers (dUAL)

Total A and B are one-directional and independent, only counting up or down depending on Count settings.

Ch-A Totalizer Add/Subtract by Ch-B Input (ud Rb)

Total of channel A will add or subtract as determined by the state of input channel B. Channel A total will add at each falling edge if input B is high, and subtract at each rising edge if input B is low.

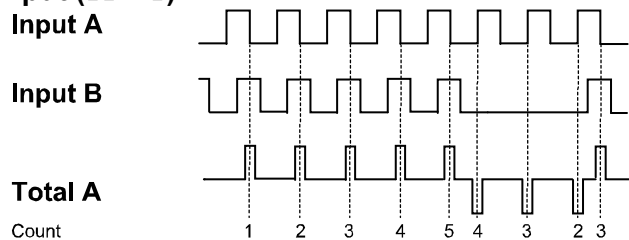

Figure 22. Dual Input Mode (ud Rb)

Ch-A Totalizer Add/Subtract by Digital Input (ud R I)

Total of channel A will add or subtract as determined by the state of a digital input. Channel A total will add at each falling edge if an assigned digital input is high, and subtract at each rising edge if an assigned digital input is low.

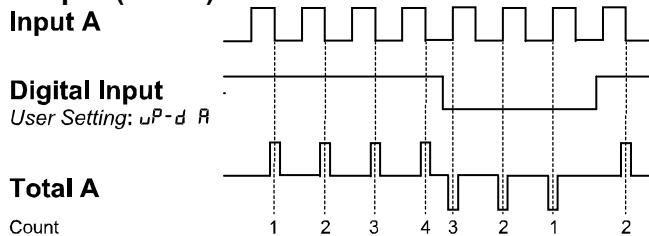

Figure 23. Dual Input Mode (ud R I)

Ch-B Totalizer Add/Subtract by Digital Input ($\mu d b i$)

Total of channel B will add or subtract as determined by the state of a digital input. Channel B total will add at each falling edge if an assigned digital input is high, and subtract at each rising edge if an assigned digital input is low.

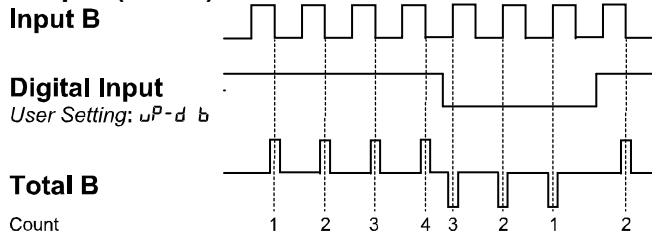

Figure 24. Dual Input Mode ($\mu d b i$)

Ch-A & Ch-B Totalizer Add/Subtract by Digital Input ($\mu d Rb$)

Totals of channel A and B will add or subtract as determined by the state of a digital input assigned to each channel. This mode combines the features of $\mu d R i$ and $\mu d b i$. This setting requires the use of a digital input. The F4 digital input will only support one channel.

Quadrature Input Type 1 ($\mathcal{Q}uRd 1$)

Quadrature modes are used to accept inputs that are ± 90 degrees out of phase, from quadrature output devices. Total of channel A will add or subtract as determined by the state of input channel B. Channel A total will add at each rising edge if channel B is high, and subtract at each rising edge if channel B is low.

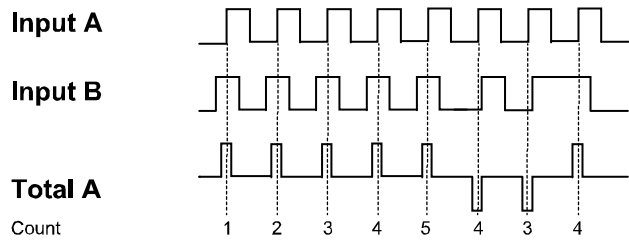

Figure 25. Dual Input Mode ($\mathcal{Q}uRd 1$)

Quadrature Input Type 2 ($\mathcal{Q}uRd 2$)

Quadrature modes are used to accept inputs that are ± 90 degrees out of phase, from quadrature output devices. Total of channel A will add or subtract as determined by the state of input channel B. Channel A total will add at each rising edge if channel B is high, and at each falling edge if channel B is low. Channel A total will subtract at each rising edge if channel B is low, and at each falling edge if channel B is high.

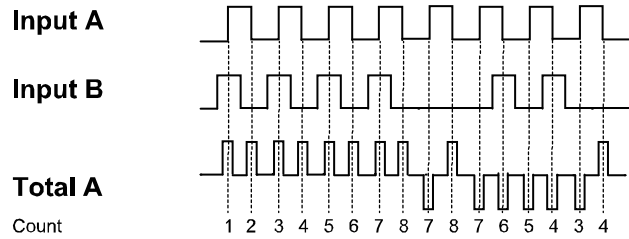

Figure 26. Dual Input Mode ($\mathcal{Q}uRd 2$)

Quadrature Input Type 4 ($\mathcal{Q}uRd 4$)

Quadrature modes are used to accept inputs that are ± 90 degrees out of phase, from quadrature output devices. Totals of channel A and B will add at each rising and falling edge of that channel.

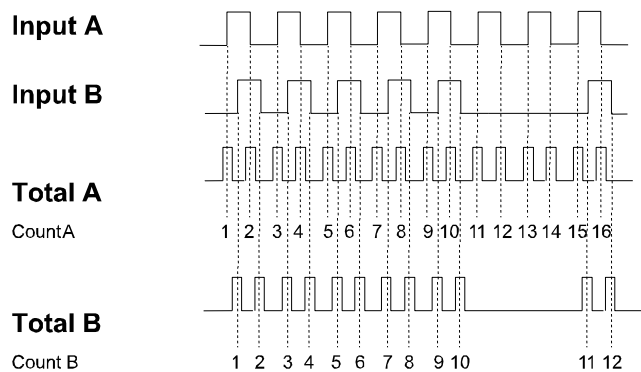

Figure 27. Dual Input Mode ($\mathcal{Q}uRd 4$)

Setting the Rate, Total, & Grand Total Units/Tags (uN t5)

Enter the channel A and B rate, total, grand total, and math channel C units (or custom tags) that will be displayed if alternating units is selected in the uN t5 menu, or d uN t5 is selected as the lower display parameter.

See the flow chart on page 29 for details on accessing the Units menu and parameters. [h-R and [h-b set the rate units, tOt-R and tOt-b the total units, and GtOt-R and GtOt-b the grand total units. [h-C sets the units for the math channel C.

See the flow chart on page 37 to access the display menu to show the unit or tag on the lower display.

The engineering units or custom legends can be set using the following 7-segment character set:

Display	Character	Display	Character	Display	Character	Display	Character
0	0	C	C	K	K	v	V
1	1	c	c	L	L	v v	w
2	2	d	d	m	m	X	X
3	3	E	E	n	n	Y	Y
4	4	F	F	O	O	Z	Z
5	5	G	G	o	o	-	-
6	6	g	g	P	P	/	/
7	7	H	H	q	q	[]
8	8	h	h	r	r]	[
9	9	I	I	S	S	:	=
A	A	i	i	t	t	°	Degree(<)
b	b	J	J	u	u		Space

Notes: Degree symbol represented by (<) if programming with MeterView® Pro. The letters “m” and “w” use two 7-segment LEDs each; when selected the characters to the right are shifted one position.

Press and hold up arrow to auto-scroll the characters in the display.

Setting the Decimal Point (dEc Pt)

The decimal point for any channel, rate, total, or grand total, may be set with up to five decimal places or with no decimal point at all.

Pressing the Right arrow moves the decimal point one place to the right until no decimal point is displayed, and then it moves to the leftmost position. Pressing the Up arrow moves the decimal point one place to the left.

There are seven decimal points to set up for three channels: Ch-A rate, total, and grand total; Ch-B rate, total, and grand total; and Ch-C.

After the decimal points are set up, the meter moves to the Program menu.

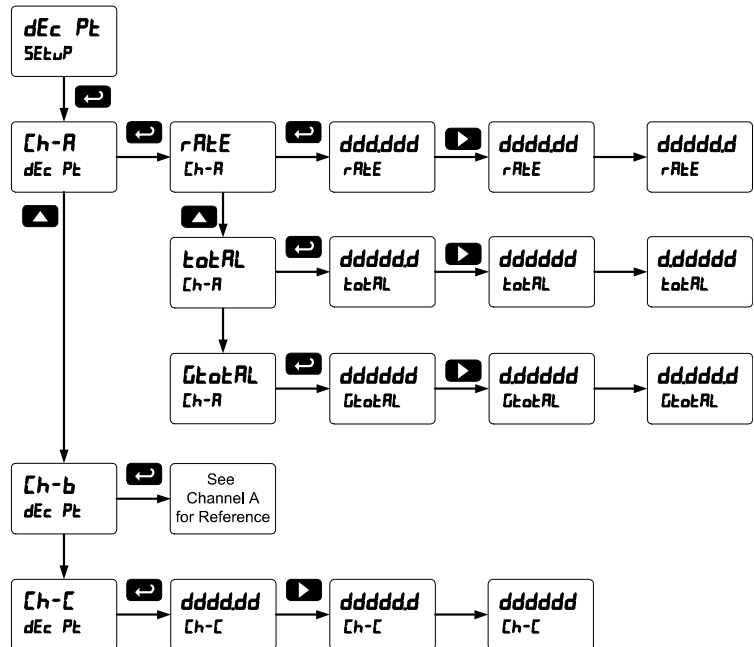

Programming the Rate/Totalizer (Prog)

It is **very important** that one reads the following information before programming the meter:

- The meter has been factory calibrated to read input frequency in Hz (pulses/sec). The calibration equipment is traceable to NIST standards.
- Use the *K-Factor* menu to match the rate/totalizer with a flowmeter's k-factor (pulse/unit of measure).
- Or use the *Scale* menu to scale the pulse input (pulse/sec) without a signal source.
- Or use *Cal* menu to calibrate the rate/totalizer using a signal source.

The *Program* menu contains the following menus for each channel A and B:

1. K-Factor calibration
2. Scale without a signal source
3. Calibrate with a calibrated signal source
4. Total time base & conversion factor
5. Grand total time base & conversion factor
6. Reset modes for total & grand total

The pulse inputs may be calibrated or scaled to any display value within the range of the meter.

Additional parameters, not needed for most applications, are found in the *Advanced Features* menu; see *Advanced Features Menu*, page 48.

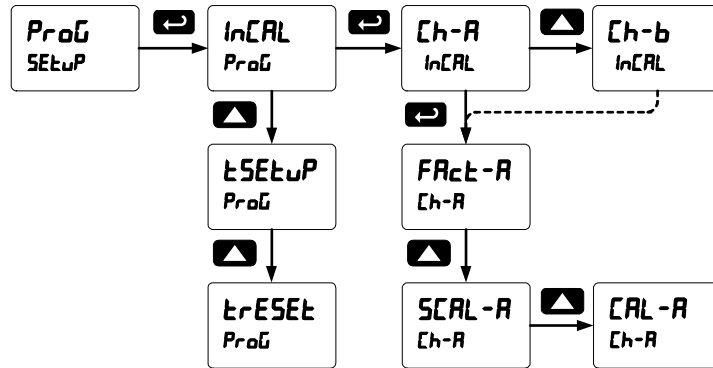

Input Calibration Method (InCAL)

There are three methods of calibrating (or scaling) the display for each input channel to show the correct engineering units.

- Use the *Factor* menu to enter the k-factor of a flowmeter in units/pulse
- Use the *Scale* menu to enter the scaling without a signal source.
- Use the *Calibrate* menu to apply a signal from a signal source.

Note: The Scale, Calibrate, and K-Factor functions are exclusive of each other. The meter uses the last function programmed. Only one of these methods can be employed at a time.

Multi-Point Calibration & Scaling

The Scale and Calibrate functions can use up to 32 points (default is 2). The number of points should be set in the Advanced menu under the Multi-Point Linearization (Linear) menu selection prior to scaling and calibration of the meter, see page 53 for details.

K-Factor Calibration (FRct-A, FRct-b)

The meter may be calibrated using the *K-Factor* function. Most flowmeter manufacturers provide this information with the device. Enter the *K-Factor* (*FRct-A*, *FRct-b*) menu and select the decimal point with highest resolution possible and program the k-factor value (*i.e.* pulses/gal). The meter will automatically calculate the flow rate using the k-factor and the time base selected.

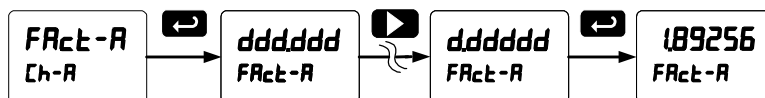

Scaling the Meter without a Signal Source (SCAL-A, SCAL-b)

The inputs can be scaled to display the process variables in engineering units.

A signal source is not needed to scale the meter; simply program the inputs and corresponding display values.

From the *InCAL* menu, select channel A or B, followed by *SCAL-A* or *SCAL-b*, and then set the signal input value and display value for each of the scaling points (default is two). Enter the signal input values in pulses/second (Hz), and the corresponding display values in appropriate engineering units. Channel B is scaled similarly to Channel A, shown below.

Scaling the Meter for Channel A (SCAL-A)

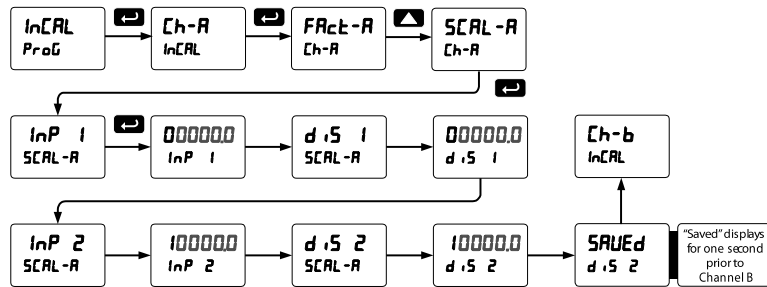

Note: The display values (*d,5 1* and *d,5 2*) need to be in units of measure per second.

For example: If the rate at 1000 Hz is 13.2 gal/min, this must be converted to gal/sec. In this scenario, the numbers input into the *SCALE* menu would be as follows:

InP 1: 0.0
d,5 1: 0.000
InP 2: 1000.0
d,5 2: 0.220

Set the time base set to minutes (see page 36) and the meter will display 13.2 gal/min at 1000 Hz

For instructions on how to program numeric values see
Setting Numeric Values, page 29.

Error Message (Error)

An error message indicates that the calibration or scaling process was not successful.

After the error message is displayed, the meter reverts to input 2 during calibration or scaling and to input 1 during internal calibration, allowing the appropriate input signal to be applied or programmed.

The error message might be caused by any of the following conditions:

1. Input signal is not connected to the proper terminals or it is connected backwards.
2. Minimum input span requirements not maintained.
3. Input 1 signal inadvertently applied to calibrate input 2.

Minimum Input Span

The minimum allowed input span is 1.0 Hz, which is the minimum difference between input 1 and input 2 signals required to complete the calibration or scaling of the meter.

Calibrating the Meter with External Source (CAL -A, CAL -b)

To scale the meter without a signal source, refer to Scaling the Meter without a Signal Source (SCAL -A, SCAL -b), page 34.

Warm up the meter for at least 15 minutes before performing calibration to ensure specified accuracy.

The meter can be calibrated to display the process variables in engineering units by applying the appropriate input signal and following the calibration procedure.

The use of a calibrated signal source is strongly recommended to calibrate the meter. Channel B is calibrated similarly to Channel A, shown below.

Calibrating the Meter for Channel A (CAL -A)

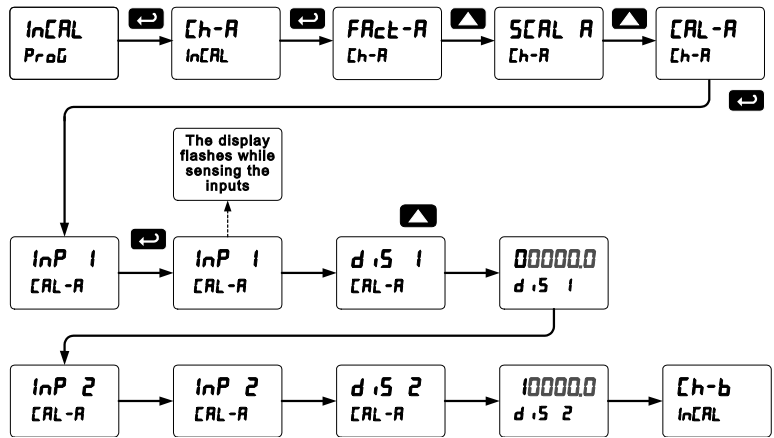

Note: The display values (d.S 1 and d.S 2) need to be in units of measure per second.

Totalizer Setup (tSEtUP)

The time base and total and grand total conversion factors for input channels A and B are located in the *Totalizer Setup* menu.

The time base is determined by the rate programming. Enter the time unit of the programmed rate scale. *For example: A rate display scaled in engineering units of gallons per minute would use a time base of minutes.*

Total & grand total conversion factors for channel A and B are programmed independently. This means that one total or grand total can be displaying the value in gallons while another displays in million gallons, liters, m³, etc.

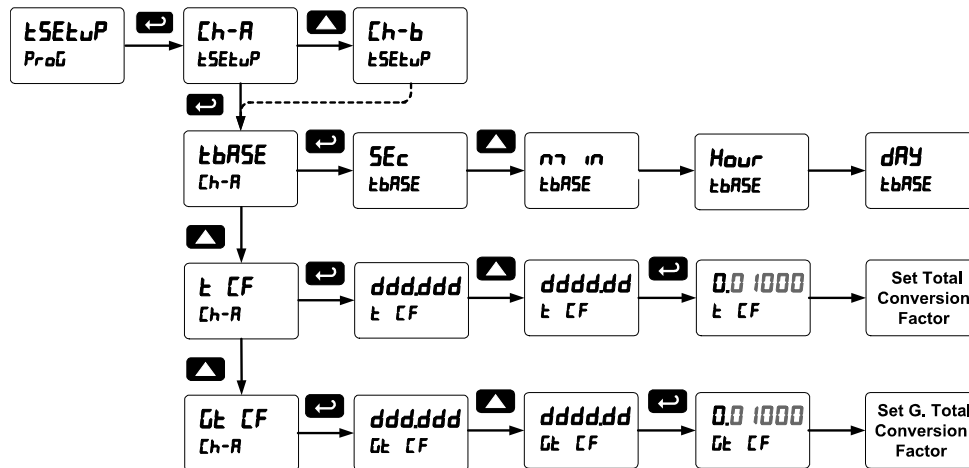

Total & Grand Total Reset (trESEt)

Total reset menus are located in the *Program* menu. The totals can be programmed for manual or automatic reset. In the automatic reset mode, a programmable time delay (**t dLY**) in seconds is available to reset the total or grand total after the assigned preset is reached.

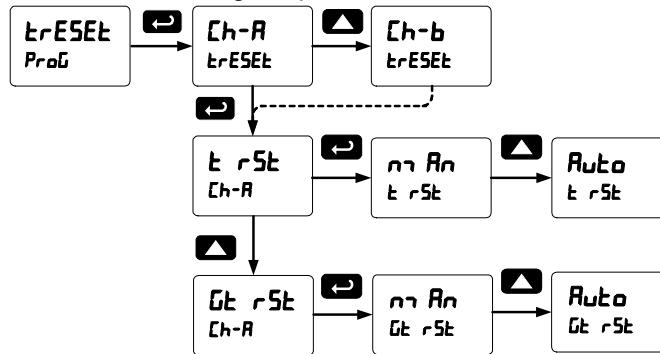

Setting the Display Parameters & Intensity (dSPRAY)

Display line 1 (LINE 1) can be programmed to display:

1. Ch-A rate (d [h-A])
2. Ch-B rate (d [h-b])
3. Ch-C math channel (d [h-C])
4. Toggle Ch-A & Ch-B rate (d Rb)
5. Toggle Ch-A rate and Ch-C (d R[C])
6. Toggle Ch-B rate and Ch-C (d b[C])
7. Toggle Ch-A & Ch-B rate, and Ch-C (d Rb[C])
8. Ch-A total (d t-A)
9. Ch-B total (d t-b)
10. Ch-A grand total (d Gt-A)
11. Ch-B grand total (d Gt-b)
12. Toggle Ch-A rate and total (d r t-A)
13. Toggle Ch-B rate and total (d r t-b)
14. Toggle Ch-A rate and grand total (d r Gt-A)
15. Toggle Ch-B rate and grand total (d r Gt-b)
16. Relay set points (1-8) (dSEt 1 to dSEt 8)
17. Max, min, and max & min values for Ch-A, Ch-B, or Ch-C (d H i-R to d H L -C)
18. Toggle Ch-A rate & units (d R-u)
19. Toggle Ch-B rate & units (d b-u)
20. Toggle Ch-C & units (d [-u)
21. Toggle Ch-A total & units (d tA-u)
22. Toggle Ch-B total & units (d tB-u)
23. Toggle Ch-A total and Ch-B total (d tAb)
24. Toggle Ch-A total, Ch-B total, and the sum of total A and total B (d tAb[C]).

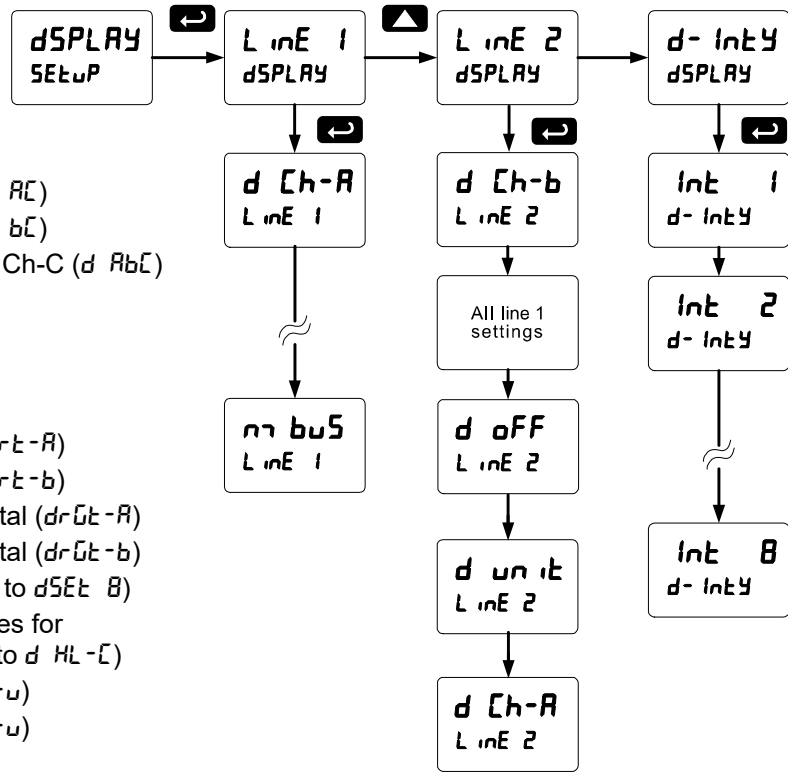

Notes: The sum of total A and B for t Rb[C] is independent of channel C programming. Channel C may be used normally by a different display selection even when d tRb[C] is selected for one of the two displays.

25. Modbus input (m bUS)

Display line 2 (LINE 2) can be programmed to display:

1. All options for display line 1
2. Off, with no display (d OFF)
3. Engineering units for any single channel, total, or grand total

Display Intensity: The meter has eight display intensity levels to give the best performance under various lighting conditions. Select intensity 8 for outdoor applications. The default intensity setting is 8.

After setting up the input and display, press the Menu button to exit programming and skip the rest of the setup menu.

Setting the Relay Operation (rELAY)

This menu is used to set up the assignment and operation of the relays.



Caution! During setup, the relays do not follow the input and they will remain in the state found prior to entering the Relay menu.

1. Relay assignment
 - a. Channel A rate, total, or grand total
 - b. Channel B rate, total, or grand total
 - c. Channel C (Math channel)
 - d. Modbus
2. Relay action
 - a. Automatic reset only (non-latching)
 - b. Automatic + manual reset at any time (non-latching)
 - c. Latching (manual reset only)
 - d. Latching with Clear (manual reset only after alarm condition has cleared)
 - e. Pump alternation control (automatic reset only)
 - f. Sampling (the relay is activated for a user-specified time)
 - g. Off (relay state controlled by Interlock feature)
3. Set point
4. Reset point
5. Fail-safe operation
 - a. On (enabled)
 - b. Off (disabled)
6. Time delay
 - a. On delay (0-999.9 seconds)
 - b. Off delay (0-999.9 seconds)

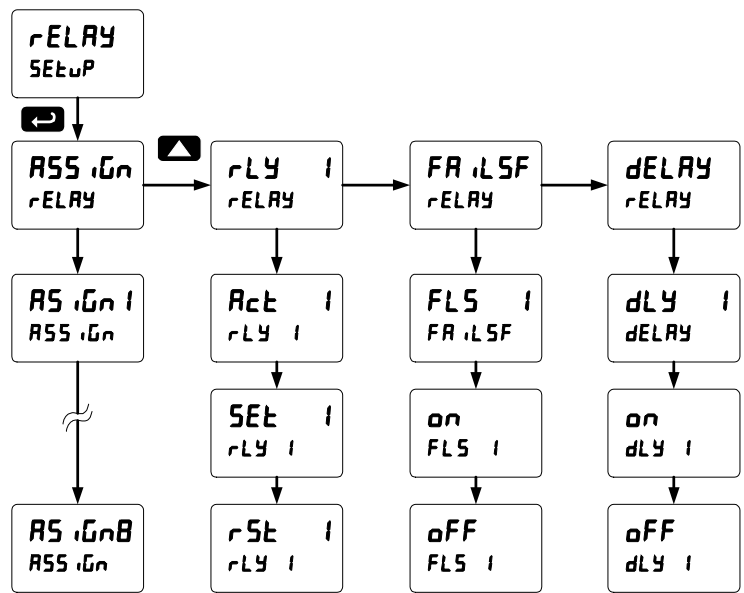

Note: The setup for relays 2-8 follows the same pattern shown here for relay 1.

Setting the Relay Assignment (ASSIGN)

Relays may be assigned to Channel A (rate, total, or grand total), Channel B (rate, total, or grand total), Channel C (Math channel), or Modbus input.

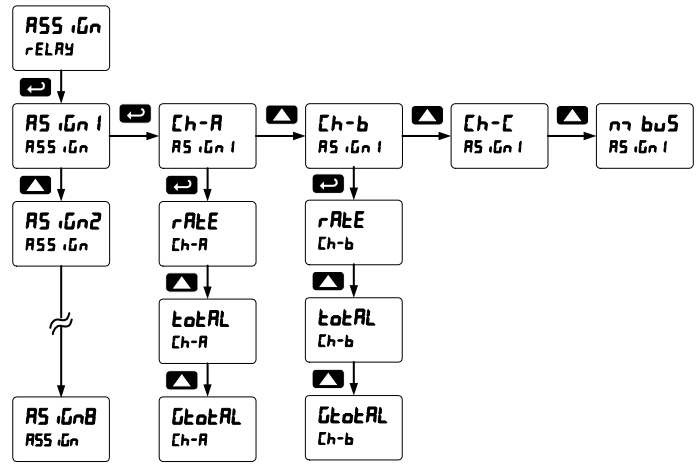

Setting the Relay Action (Act)

Operation of the relays is programmed in the *Action* menu. The relays may be set up for any of the following modes of operation:

1. Automatic reset (non-latching)
2. Automatic + manual reset at any time (non-latching)
3. Latching (manual reset only, at any time)
4. Latching with Clear (manual reset only after alarm condition has cleared)
5. Pump alternation control (automatic reset only)
6. Sampling (the relay is activated for a user-specified time)
7. Off (relay state controlled by Interlock feature)

The following graphic shows relay 1 action setup; relay 2-4 are set up in a similar fashion.

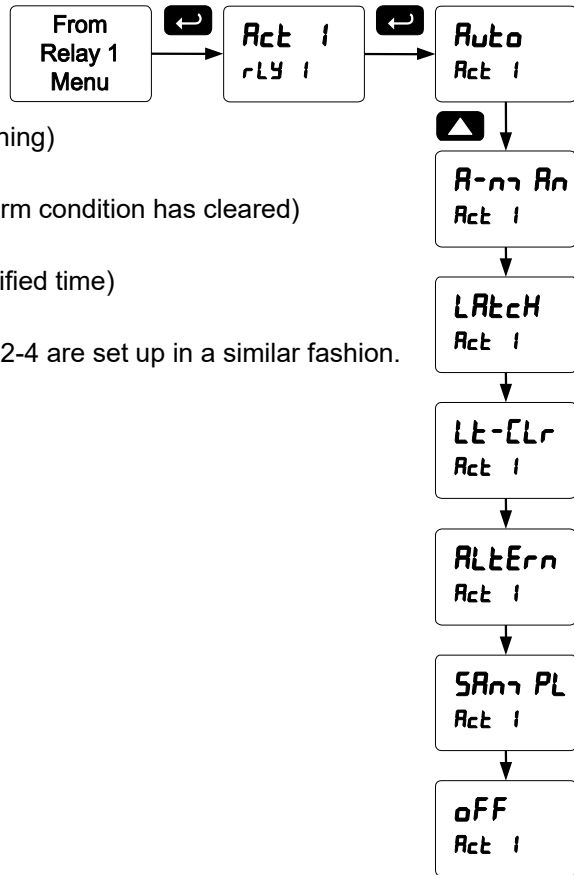

Programming Set and Reset Points

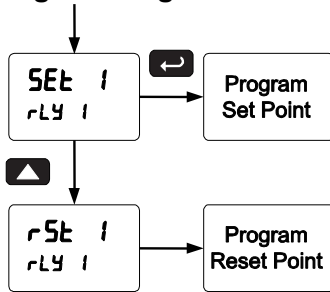

High alarm indication: program set point above reset point.
 Low alarm indication: program set point below reset point.
 The deadband is determined by the difference between set and reset points. Minimum deadband is one display count. If the set and reset points are programmed with the same value, the relay will reset one count below the set point.

Note: Changes are not saved until the reset point has been accepted.

Setting Fail-Safe Operation

In fail-safe mode of operation, the relay coil is energized when the process variable is within safe limits and the relay coil is de-energized when the alarm condition exists. The fail-safe operation is set independently for each relay. Select **on** to enable or select **OFF** to disable fail-safe operation.

Programming Time Delay

The *On* and *Off* time delays may be programmed for each relay between 0 and 999.9 seconds. The relays will transfer only after the condition has been maintained for the corresponding time delay.

The *On* time delay is associated with the set point.

The *Off* time delay is associated with the reset point.

Relay and Alarm Operation Diagrams

The following graphs illustrate the operation of the relays, status LEDs, and ACK button.

High Alarm Operation (Set > Reset)

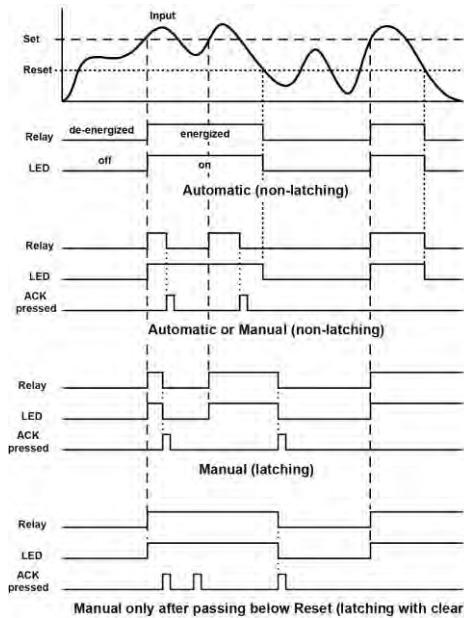

For Manual reset mode, ACK can be pressed anytime to turn "off" relay. To detect a new alarm condition, the signal must go below the set point, and then go above it.

Low Alarm Operation (Set < Reset)

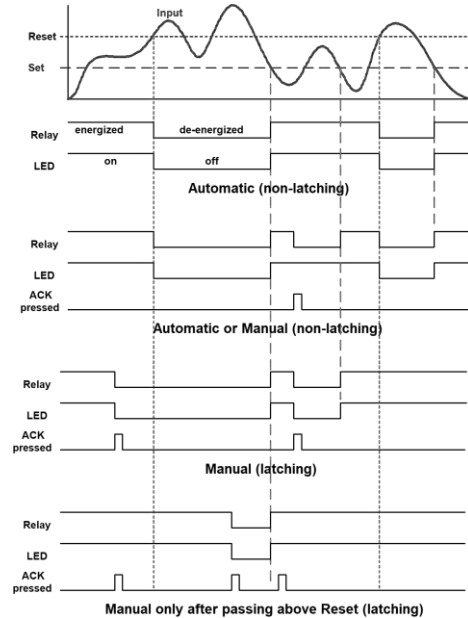

For Manual reset mode, ACK can be pressed anytime to turn "off" relay. For relay to turn back "on", signal must go above set point and then go below it.

High Alarm with Fail-Safe Operation (Set > Reset)

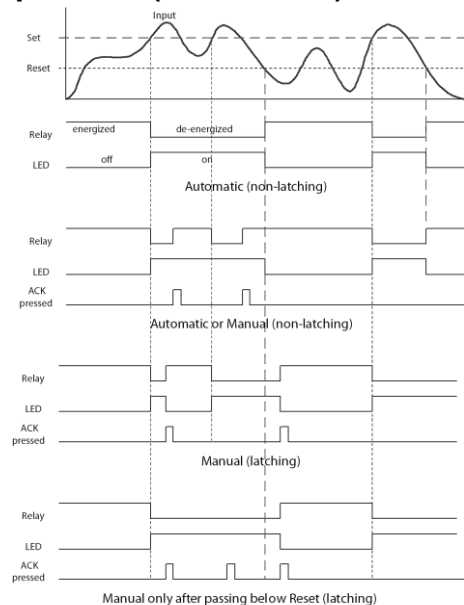

Note: Relay coil is energized in non-alarm condition. In case of power failure, relay will go to alarm state.

Low Alarm with Fail-Safe Operation (Set < Reset)

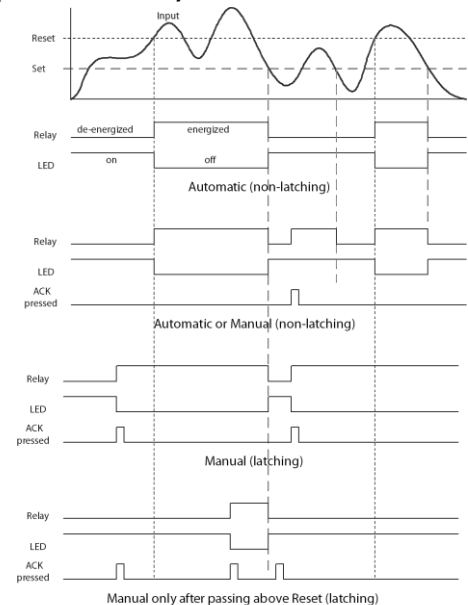

Note: Relay coil is energized in non-alarm condition. In case of power failure, relay will go to alarm state.

Pump Alternation Control Operation

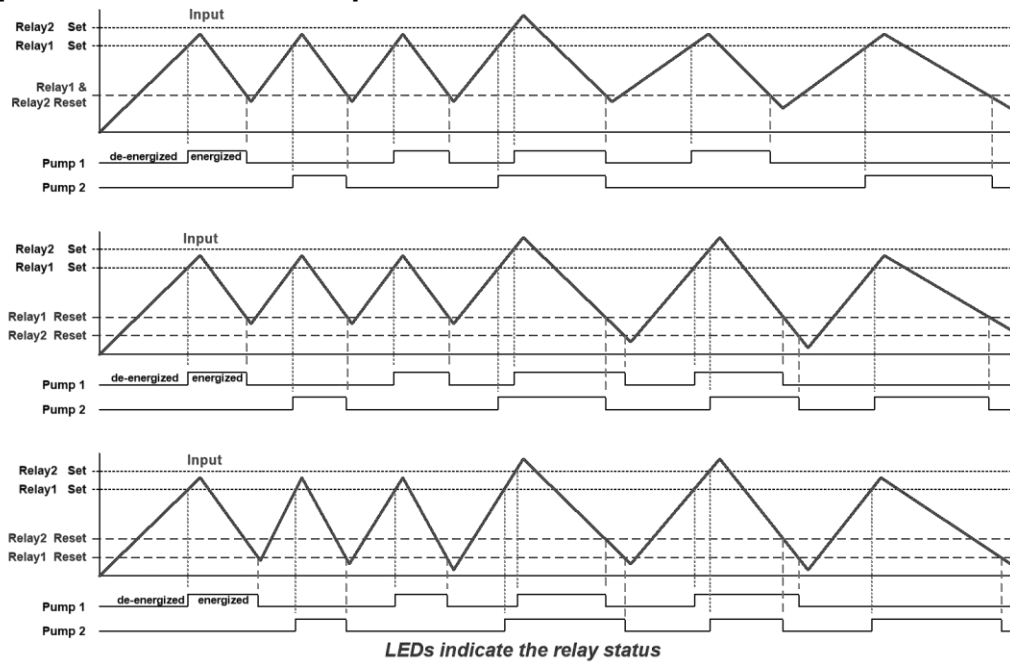

Relay Sampling Operation

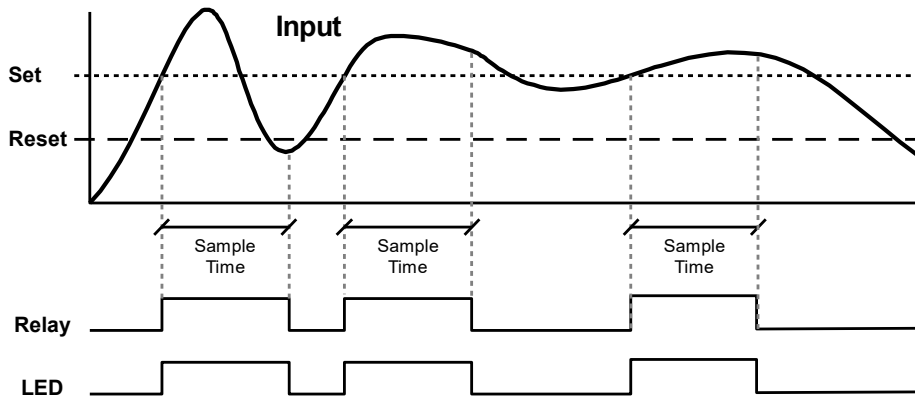

When the signal crosses the set point, the relay trips and the sample time starts. After the sample time has elapsed, the relay resets. The cycle repeats every time the set point is crossed, going up for high alarms and going down for low alarms.

The sample time can be programmed between 0.1 and 5999.9 seconds.

Total Relay Sampling Operation

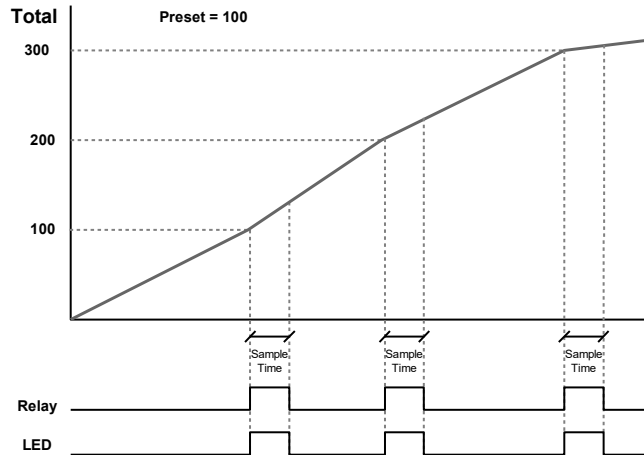

When the total reaches the preset, the relay trips and the sample time starts. After the sample time has elapsed, the relay resets. The cycle repeats every time the preset value is added to the total.

Time Delay Operation

The following graphs show the operation of the time delay function.

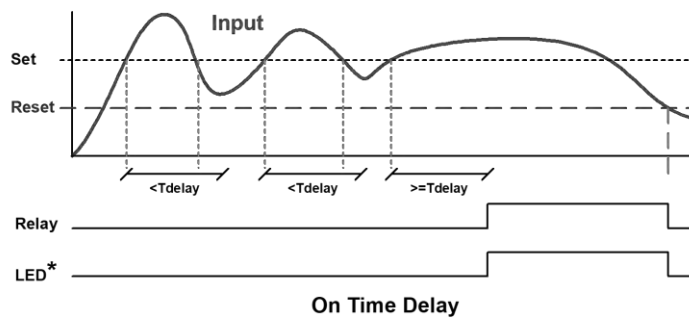

On Time Delay

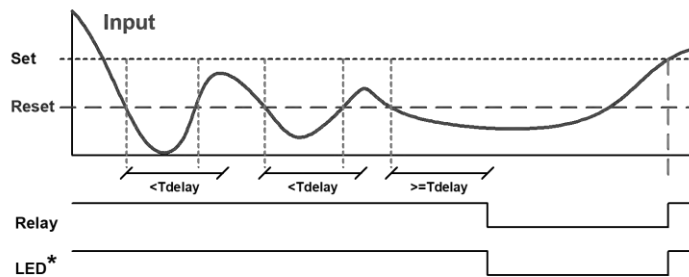

Off Time Delay

When the signal crosses the set point, the *On* time delay timer starts and the relay trips when the time delay has elapsed. If the signal drops below the set point (high alarm) before the time delay has elapsed, the *On* time delay timer resets and the relay does not change state. The same principle applies to the *Off* time delay.

Note: If "Automatic or Manual (R-nn Rn)" reset mode is selected, the LED follows the reset point and not the relay state when the relay is acknowledged.

Relay Operation Details

Overview

The relay capabilities of the meter expand its usefulness beyond simple indication to provide users with alarm and control functions. These capabilities include front panel alarm status LEDs as well as either 2 or 4 optional internal relays. Typical applications include high or low temperature, level, pressure or flow alarms, control applications such as simple on/off pump control, and pump alternation control for up to 4 pumps. There are four basic ways the relays can be used:

1. High or Low Alarms with Latching or Non-Latching Relays
2. Simple On/Off Control with 100% Adjustable Deadband
3. Sampling (Based on Time)
4. Pump Alternation Control for up to 4 Pumps

Relays Auto Initialization

When power is applied to the meter, the front panel LEDs and alarm relays will reflect the state of the input to the meter. The following table indicates how the alarm LEDs and relays will react on power-up based on the set and reset points.

Alarm #	HI or LO Alarm	Set Point	Reset Point	Power-Up Reading	Relay & LED
1	HI	1000	500	499	Off
2	LO	700	900	499	On
3	LO	250	400	499	Off
4	HI	450	200	499	On

Fail-Safe Operation

The following table indicates how the relays behave based on the fail-safe selection for each relay:

Note: NO = Normally Open, NC = Normally Closed. This refers to the condition of the relay contacts when the power to the meter is off.

Fail-Safe Selection	Non-Alarm State		Alarm State		Power Failure
	NO	NC	NO	NC	
Off	Open	Closed	Closed	Open	Relays go to non-alarm state
On	Closed	Open	Open	Closed	Relays go to alarm state

Front Panel LEDs

The LEDs on the front panel provide status indication for the following:

The meter is supplied with four alarm points that include front panel LEDs to indicate alarm conditions. This standard feature is particularly useful for alarm applications that require visual-only indication. The LEDs are controlled by the set and reset points programmed by the user. When the display reaches a set point for a high or low alarm, the corresponding alarm LED will turn on. When the display returns to the reset point the LED will go off. The front panel LEDs responds differently for latching and non-latching relays.

LED	Status
1	Alarm 1
2	Alarm 2
3	Alarm 3
4	Alarm 4

LED	Status
5	Alarm 5
6	Alarm 6
7	Alarm 7
8	Alarm 8

For non-latching relays, the LED is always off during normal condition and always on during alarm condition, regardless of the state of the relay (e.g. Relay acknowledged after alarm condition).

For latching relays, the alarm LEDs reflects the status of the relays, regardless of the alarm condition. The following tables illustrate how the alarm LEDs function in relation to the relays and the acknowledge button (Default: F3 key assigned to ACK).

Latching and Non-Latching Relay Operation

The relays can be set up for latching (manual reset) or non-latching (automatic reset) operation.

The On and Off terminology does not refer to the status of the relay's coil, which depends on the fail-safe mode selected.

Relay terminology for following tables	
Terminology	Relay Condition
On	Alarm (Tripped)
Off	Normal (Reset)
Ack	Acknowledged



Warning! *In latching relay mode, latched relays will reset (unlatch) when power is cycled.*

Non-Latching Relay (RULC)

In this application, the meter is set up for automatic reset (non-latching relay). Acknowledging the alarm while it is still present has no effect on either the LED or the relay. When the alarm finally goes away, the relay automatically resets and the LED also goes off.

Automatic reset only		
Condition	LED	Relay
Normal	Off	Off
Alarm	On	On
Ack (No effect)	On	On
Normal	Off	Off

Non-Latching Relay (R-n Rn)

In this application, the meter is set up for automatic and manual reset at any time (non-latching relay). The LED and the relay automatically reset when the meter returns to the normal condition.

The next time an alarm occurs, the operator acknowledges the alarm manually while the alarm condition still exists. This causes the relay to reset, but the LED stays on until the meter returns to the normal condition.

Automatic + manual reset at any time		
Condition	LED	Relay
Normal	Off	Off
Alarm	On	On
Normal	Off	Off
Next Alarm	On	On
Ack	On	Off
Normal	Off	Off

Latching Relay (LRCH)

In this application, the meter is set up for manual reset at any time. Acknowledging the alarm even if the alarm condition is still present resets the relay and turns off the LED.

Manual reset any time		
Condition	LED	Relay
Normal	Off	Off
Alarm	On	On
Ack	Off	Off

Latching Relay (LR-LR)

In this application, the meter is set up for manual reset only after the signal passes the reset point (alarm condition has cleared). Acknowledging the alarm while it is still present has no effect on either the LED or the relay. When the alarm is acknowledged after it returns to the normal state, the LED and the relay go off. Notice that the LED remains on, even after the meter returns to the normal condition. This is because, for latching relays, the alarm LED reflects the status of the relay, regardless of the alarm condition.

Manual reset only after alarm condition has cleared		
Condition	LED	Relay
Normal	Off	Off
Alarm	On	On
Ack (No effect)	On	On
Normal	On	On
Ack	Off	Off

Acknowledging Relays

There are two ways to acknowledge relays programmed for manual reset:

1. Via the programmable front panel function keys F1-F3 (Default: F3 assigned to ACK).
2. Remotely via a normally open pushbutton wired across one of the digital inputs and the +5 V terminals on the digital I/O modules, or using the F4 digital input, which is triggered with a contact closure to COM, or with an active low signal (see page 20).

When the ACK button or the assigned digital input is closed, all relays programmed for manual reset are acknowledged.

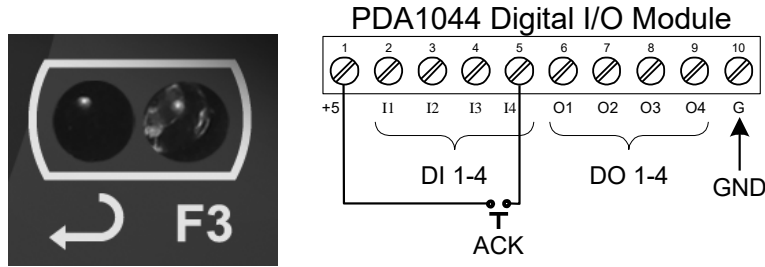

Figure 28. Acknowledge Relays w/Function Key or Digital Input

Setting Up the Interlock Relay (Force On) Feature

Relays 1-4 can be set up as interlock relays. To set up the relays for the interlock feature:

1. Access the *Setup – Relay – Action* menu and set the action to off.
2. In the *Advanced features – User* menu program any of the digital inputs to *Force On* any of the internal relays (1-4).
3. Connect a switch or dry contact between the +5V terminal and the corresponding digital input (di-1 to di-4) terminal.

Note: If multiple digital inputs are assigned to the same relay, then the corresponding logic is (AND) – i.e. both switches must be closed to trip the relay.

Scaling the 4-20 mA Analog Output (Rout)

The 4-20 mA analog outputs can be scaled to provide a 4-20 mA signal for any display range selected. To select the channel and source assignments the analog outputs are assigned to, see *Analog Output Source* on page 56.

No equipment is needed to scale the analog outputs; simply program the display values to the corresponding mA output signal.

The *Analog Output* menu is used to program the 4-20 mA outputs based on display values.

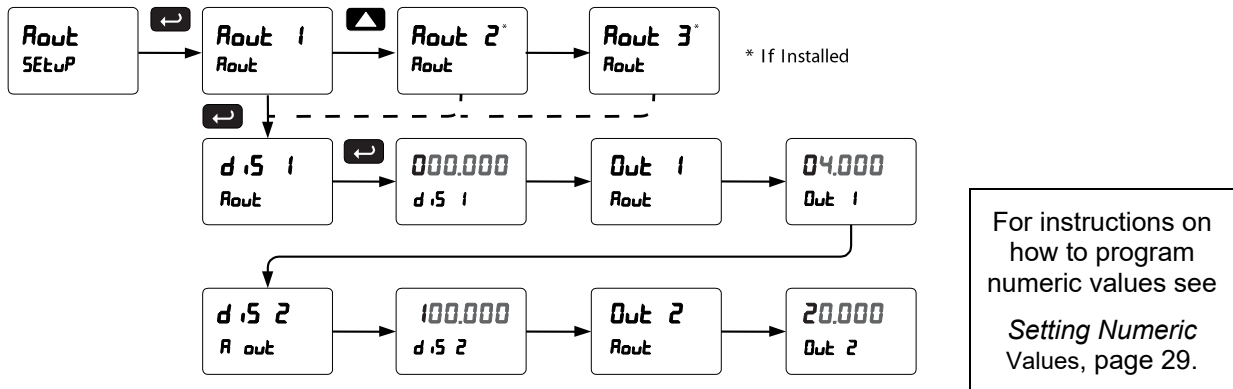

Reset Menu (rESEt)

The *Reset* menu is used to reset the maximum (peak) value of Ch-A and Ch-B rate (r5t H i), minimum (valley) reading of Ch-A and Ch-B rate (r5t L o), both high and low value of Ch-A and Ch-B rate (r5t H L), Ch-A total (t o t A) or Ch-B total (t o t b), Ch-A grand total (G t o t A) or Ch-B grand total (G t o t b), both Ch-A and Ch-B totals (t o t A b), or both Ch-A and Ch-B grand totals (G t A b).

Control Menu (C o n t r L)

The *Control* menu is used to control the 4-20 mA analog output (Aout 1 only) and the relays manually, ignoring the input. Each relay and analog output can be programmed independently for manual control. Selecting automatic control sets all relays and analog output for automatic operation.

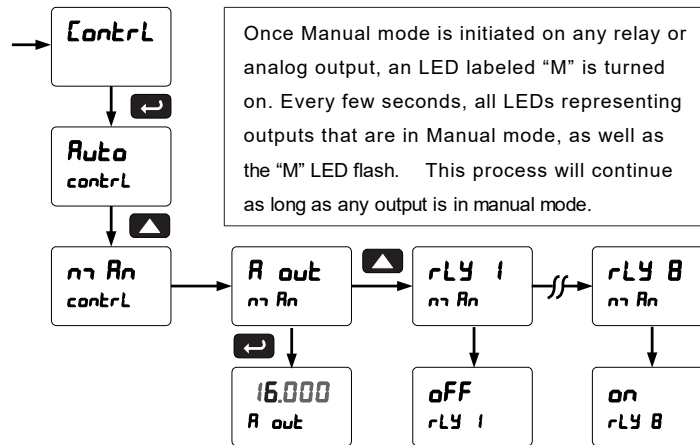

Setting Up the Password (P ASS)

The *Password* menu is used for programming three levels of security to prevent unauthorized changes to the programmed parameter settings, to restrict the ability to reset the totals and grand totals, and to program the non-resettable totalizer.

Pass 1: Allows use of function keys and digital inputs
 Pass 2: Allows use of function keys, digital inputs and editing set/reset points
 Pass 3: Restricts all programming, function keys, and digital inputs.
 Total: Prevents resetting the total manually
 Gtotal: Prevents resetting the grand total manually

Protecting or Locking the Meter Functions

Enter the *Password* menu and program a six-digit password.

For instructions on how to program numeric values see

Setting Numeric Values, page 29.

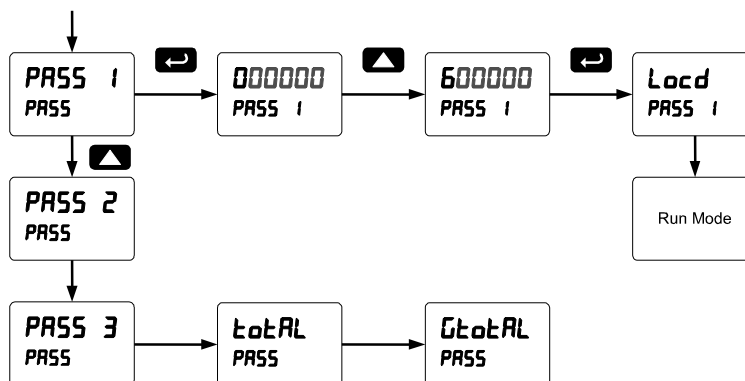

Total Reset Password & Non-Resettable Total

The total and the grand total can be password-protected to prevent unauthorized total resets. The grand total can be programmed as a non-resettable total by entering the password "050873".



Caution! Once the Grand Total has been programmed as "non-resettable" the feature **cannot** be disabled.

Making Changes to a Password Protected Meter

If the meter is password protected, the meter will display the message *Locd* (Locked) when the Menu button is pressed. Press the Enter button while the message is being displayed and enter the correct password to gain access the menu. After exiting the programming mode, the meter returns to its password protected condition.

Disabling Password Protection

To disable the password protection, access the *Password* menu and enter the correct password twice, as shown below. The meter is now unprotected until a new password is entered.

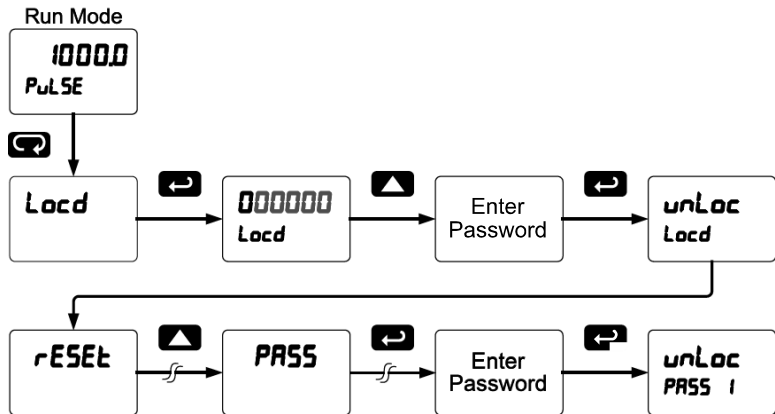

If the correct six-digit password is entered, the meter displays the message *unLoc* (unlocked) and the protection is disabled until a new password is programmed.

If the password entered is incorrect, the meter displays the message *Locd* (Locked) for about two seconds, and then it returns to Run Mode. To try again, press Enter while the *Locked* message is displayed.

Did you forget the password?

The password may be disabled by entering a master password once. If you are authorized to make changes, enter the master password 508655 to unlock the meter.

Advanced Features Menu

To simplify the setup process, functions not needed for most applications are located in the *Advanced Features* menu.

Press and hold the Menu button for three seconds to access the advanced features of the meter.

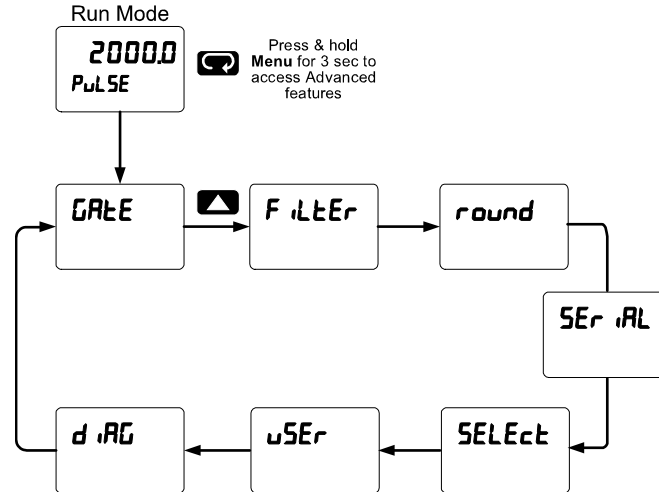

Advanced Features Menu & Display Messages

The following table shows the functions and messages of the *Advanced Features* menu in the order they appear in the menu.

Display	Parameter	Action/Setting	Display	Parameter	Action/Setting
GATE	Gate	Enter Gate function menu	t-byt	Time byte	Set byte-to-byte timeout
Lo G	Low gate	Program Low gate value	SELEct	Select	Enter the Select menu (function, math, constant, cutoff, count, Aout programming)
Hi G	High gate	Program High gate value	Function	Signal input conditioning	Select linear function parameters
FILTER	Filter	Enter the Filter menu	Ch-A	Channel A	Select menu for channel A
Ch-A	Channel A	Set filter speed for channel A	Ch-B	Channel B	Select menu for channel B
Ch-B	Channel B	Set filter speed for channel B	LinER	Linear	Set meter for linear function and select number of linearization points
Lo SPD	Low speed	Set the contact debounce filter value	no Pts	Number of points	Set the number of linearization points (default: 2)
Hi SPD	High speed	Select high speed filter	Math	Math	Select the channel C math function
round	Round	Set the rounding value for the display	Sum	Sum	$C = (A+B+P)*F$
SERIAL	Serial	Set serial communication parameters	dIF	Difference	$C = (A-B+P)*F$
SLAVE ID	Slave ID	Set slave ID or meter address	dIFABS	Abs difference	$C = ((\text{Absolute value of } (A-B))+P)*F$
baud	Baud rate	Select baud rate	Avg	Average	$C = (((A+B)/2)+P)*F$
tr dLY	Transmit delay	Set serial communication transmit delay	Multi	Multiplication	$C = ((A*B)+P)*F$
PARITY	Parity	Select parity Even, Odd, or None with 1 or 2 stop bits	dIDE	Divide	$C = ((A/B)+P)*F$

Display	Parameter	Action/Setting
H ስ-ጸb	Max of A or B	$C = ((\text{High value of channel A or B}) + P) * F$
ኒ ስ-ጸb	Min of A or B	$C = ((\text{Low value of channel A or B}) + P) * F$
dr ጸሀሀ	Draw	$C = ((A/B) - 1) * F$
ሀሀ ጸሀሀ	Weighted avg.	$C = ((B-A) * F) + A$
r ጸቴ ስ	Ratio	$C = (A/B) * F$
r ጸቴ ስፊ	Ratio 2	$C = ((B-A)/A) + P * F$
ኒ ስጠርጸክ	Concentration	$C = (A/(A+B)) * F$
ፍሀገገ ቴ	Sum total	$C = (tA + tB + P) * F$
ፍሀገገፍቴ	Sum grand total	$C = (GtA + GtB + P) * F$
d ስF ቴ	Diff. of total	$C = (tA - tB + P) * F$
d ስF ፍቴ	Difference of grand total	$C = (GtA - GtB + P) * F$
ቴ r ጸቴ ስ	Total ratio	$C = (tA/tB) * F$
ቴ - r ጸቴ ፊ	Total ratio 2	$C = ((tB - tA)/tA) * F$
ቴ P ርቴ	Total percent	$C = (tA/(tA + tB)) * 100$
ኒ ስጠናቴ	Constant	Enter math equation constants
RddEr	Adder	Addition constant used in channel C math calculations (P)
Fጸርቴ	Factor	Multiplication constant used in channel C math calculations (F)
ኒ ሀቴ ስFF	Cutoff	Set low-flow cutoff
ኒ ስ-ጸ	Channel A	Set low-flow cutoff for Channel A
ኒ ስ-ጸb	Channel B	Set low-flow cutoff for Channel B
ኒ ስጠናቴ	Count	Set total count direction
ኒ ስ-ጸ	Channel A	Set total count direction for Channel A
ኒ ስ-ጸb	Channel B	Set total count direction for Channel B
ቴ ስቴ ኒ	Total count	Set direction of total count
ፍቴ ስቴ ኒ	G. total count	Set direction of grand total count
ሀP	Count up	Count up
ሀፍሀፍ	Count down	Count down

Display	Parameter	Action/Setting
ኒ ፍቴ ስቴ	Count start	Enter count down start value
RጠቴPr	Analog output programming	Program analog output parameters
Rጠቴ ስ*	Analog output 1	Program analog output 1 (*1-3) parameters
ፍጠሬርጸ	Source	Select source for the 4-20 mA output
ኒ ጸሬ ስb	Calibrate	Calibrate 4-20 mA output
ሃ ገገ ጸ	4 mA output	Enter mA output value read by milliamp meter with at least 0.001 mA resolution
ፊ ገገ ጸ	20 mA output	Enter mA output value read by milliamp meter with at least 0.001 mA resolution
ፍ-r ጸሬ	Overrange	Program mA output for display overrange
ሀ-r ጸሬ	Underrange	Program mA output for display underrange
ገገ ጸH	Maximum	Program maximum mA output allowed
ገገ ስ	Minimum	Program minimum mA output allowed
ሀፍጸ	User I/O	Assign function keys and digital I/O
F ስ*	F1* function key	Assign F1 function key (*F1/F2/F3)
Fሃ	F4 digital input	Assign F4 function (digital input)
d ስ ስ	Digital input 1	Assign digital input 1 – 4
d ፍ ስ	Digital output 1	Assign digital output 1 – 4
d ጸሬ	Diagnostics	Display parameter settings
ኒ ጸሬ ቴ	LED test	Test all LEDs
ኒ ጸሬ	Information	Display software and S/N information
Er ጸፍጸ	Erase	Erase MeterView Pro software stored in meter's memory

Gate Function (GATE)

The gate function (GATE) is the first option in the Advanced Features menu. There are two settings for the GATE, low gate (Lo G) and high gate (Hi G). Channel A and B use the same gate settings.

The gate function is used for displaying slow pulse rates. Using the programmable gate, the meter is able to display pulse rates as slow as 1 pulse every 999.9 seconds (0.001 Hz). The gate function can also be used to obtain a steady display reading with a fluctuating input signal.

Low Gate (Lo G)

For most applications, low gate setting should be left at 1.0 second. Increase low gate setting to obtain a steadier rate display. The rate display will update in accordance with the low gate setting, for example if low gate is set at 10.0, the display will update every 10 seconds; changes in rate between updates will not be reflected until next display update.

High Gate (Hi G)

Set the high gate value to correspond to the highest expected pulse period (lowest pulse rate). For instance if the meter must display a rate when there is 1 pulse coming into the meter every 10 seconds, set the high gate to 11.0 seconds. When the signal is removed from the meter, the display will show the last reading for 11 seconds; then it will read zero.

Gate Settings

Slow Pulse Rate		
Low Gate* (sec)	High Gate (sec)	Min Freq** (Hz)
1.0	2.0	0.5000
1.0	10.0	0.1000
1.0	20.0	0.0500
1.0	100.0	0.0100
1.0	200.0	0.0050
1.0	400.0	0.0025
1.0	800.0	0.0012
1.0	999.9	0.0010
*The low gate setting corresponds to the display update rate and is used to stabilize the display reading with a fluctuating signal.		
**The minimum frequency is dependent on high gate setting.		

Contact De-Bounce Filter (FILTERR)

The filter function (FILTERR) is the second option in the Advanced Features menu. The filter function (FILTERR) can be used for applications where the meter is set up to count pulses generated by switch contacts. The filter value can be set anywhere between 2 and 50, the higher the value, the greater the filtering. Channel A and B have independent settings.

There are two settings, Hi SPd (high speed) and Lo SPd (low speed). After pressing ENTER to select Lo SPd, enter the desired filter setting based on the table below so that there are no extra counts when a contact closure is completed. Selecting Hi SPd does not require a programmable filter value.

Filter Settings

Contact De-Bounce Filter		
Filter Setting	Speed Setting	Max Freq (Hz)
2	Lo SPd	999
4	Lo SPd	499
8	Lo SPd	249
16	Lo SPd	124
32	Lo SPd	62
40	Lo SPd	50
50	Lo SPd	40
N/A	Hi SPd	30,000

Rounding Feature (round)

The rounding feature is used to give the user a steadier display with fluctuating signals. Rounding is used in addition to the filter function.

Rounding causes the display to round to the nearest value according to the rounding selected. This setting affects the last two digits, regardless of decimal point position.

Modbus RTU Serial Communications (SERIAL)

The meter is equipped with serial communications capability as a standard feature using Modbus RTU Serial Communication Protocol.

The meter may be connected to a PC for initial configuration via the onboard micro USB connection. For ongoing digital communications with a computer or other data terminal equipment, an RS-232, or RS-485 option is required; see *Ordering Information* on page 5 for details.



Warning! Do not connect any equipment other than Precision Digital's expansion modules, cables, or meters to the RJ45 M-LINK connector. Otherwise damage will occur to the equipment and the meter.

Note: More detailed instructions are provided with each optional serial communications adapter.

Note: Refer to the ProVu® Modbus Register Tables located at www.predig.com for details.

When using more than one meter in a multi-drop mode, each meter must be provided with its own unique address. The meter address (Slave ID) may be programmed between 1 and 247. The transmit delay may be set between 0 and 199 ms. The parity can be set to even, odd, or none with 1 or 2 stop bits.

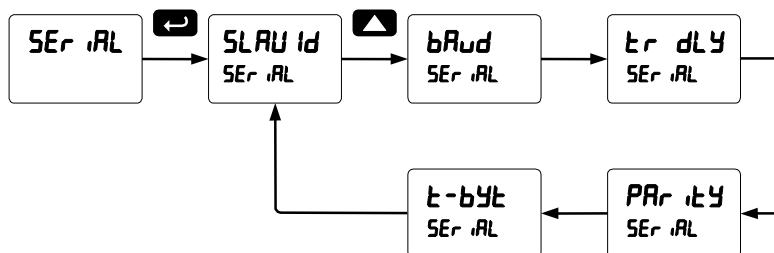

Changes made to the Serial menu are initialized after the MENU key is pressed or after navigating through the t-byte parameter.

Serial Communications Overview

RS-232 and RS-485 are standard interfaces approved by the Electronic Industries Alliance (EIA) for connecting serial devices. In EIA terms, the device (e.g. meter) that connects to the interface is called a Data Communications Equipment (DCE) and the device to which it connects (e.g. the computer) is called a Data Terminal Equipment (DTE).

RS-485 can support multi-point connections per line because it uses lower-impedance drivers and receivers.

Line drivers and receivers are used to exchange data between two or more points (nodes) on a serial communications network. Reliable data communications can be difficult in the presence of induced noise, ground level differences, and other hazards associated with installation of a network. When communicating at high data rates, or over long distances in real world environments, RS-232 is often inadequate. The differential data transmission of RS-485 offers superior performance in most applications. Differential signals can help nullify the effects of ground shifts and induced noise signals that can appear as common mode voltages on a network.

A multi-point network consists of multiple drivers and receivers connected on a single bus, where any point (node) can transmit and/or receive data. RS-485 allows multiple drivers and receivers on the same two-wire or four-wire system. The RS-485 standard specifies up to 32 drivers and 32 receivers on a single bus, but with the introduction of "automatic" repeaters and high-impedance drivers/receivers, this number can be extended to hundreds of points (nodes) on a network.

The cabling used for an RS-485 serial communications network should always be a high quality cable such as Belden 8162 or Alpha 6203C. A two-wire system requires two twisted pairs, and a four-wire system requires three twisted pairs (the extra twisted pair is needed for the signal ground).

Figure 29 illustrates how to connect a general four-wire network (a four-wire network actually contains 5 wires).

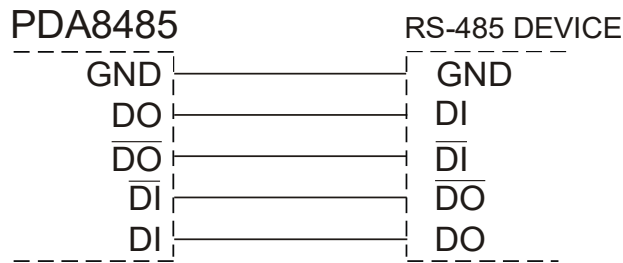

Figure 29: General Four-Wire Network Connection

Figure 30 illustrates how to connect a general two-wire network (a two-wire network actually contains 3 wires). Note that the PDA7485 and PDA8485 have DIP switches that allow for two-wire connections without the need to externally wire the DO to the DI and the /DO to the /DI (see the converter section for complete details).

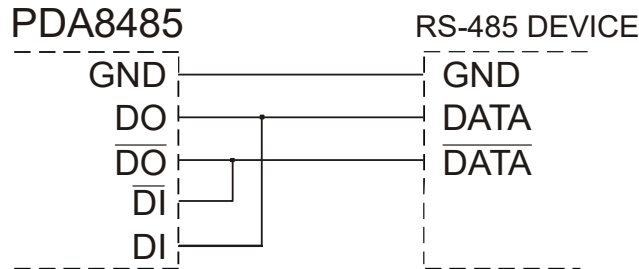
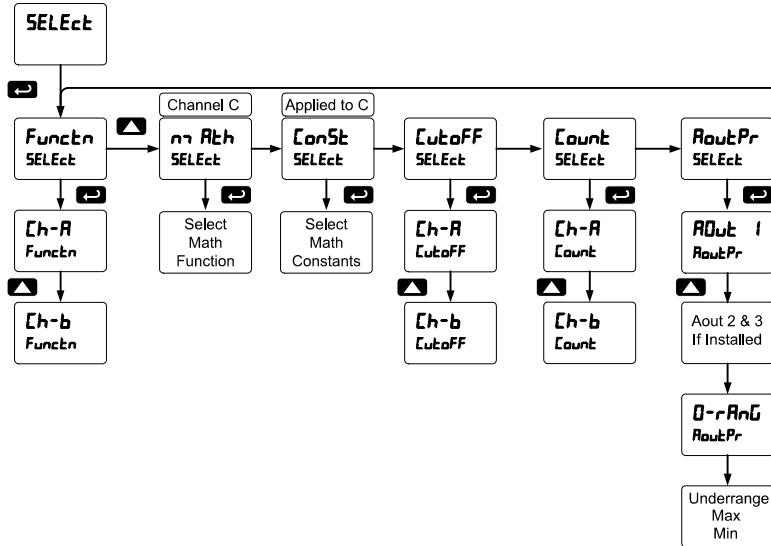

Figure 30: General Two-Wire Network Connection

Select Menu (SELEct)

The *Select* menu is used to select the signal input conditioning function applied to the inputs, math function for A & B, constants, low-flow cutoff, total count direction (up or down from a preset amount), and analog output programming. Multi-point linearization is part of the linear function selection.



Signal Input Conditioning (Functn)

The *Function* menu is used to condition the linear input signal. Multi-point linearization is part of the linear function selection. Each input channel signal input conditioning function is programmed independently.

Multi-Point Linearization (L inERr)

Meters are set up at the factory for linear function with 2-point linearization. Up to 32 linearization points can be selected for each channel under the linear function. The multi-point linearization can be used to linearize the display for non-linear signals such as those from level transmitters used to measure volume in odd-shaped tanks or to convert level to flow using weirs and flumes with complex exponent.

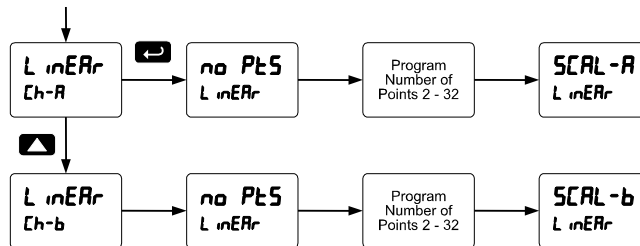

Note: After Scale is displayed continue pressing the Enter button until the meter completes the scaling of the input and display values.

Math Function (מחשבים)

The *Math* menu is used to select the math function that will determine the channel C value. These math functions are a combination of input channels A and B, and will display when channel C is selected in the *Display* menu.

A and B refer to the rate of channel A and B. tA and tB refer to the totals of channel A and B. GtA and GtB refer to the grand totals of channel A and B. The following math functions are available.

Function	Display	Description
סכום	Sum	$C = (A+B+P)*F$
דו"פ	Difference	$C = (A-B+P)*F$
דו"פ אב	Abs difference	$C = ((\text{Absolute value of } (A-B))+P)*F$
מוצ"ט	Average	$C = (((A+B)/2)+P)*F$
מכפלה	Multiplication	$C = ((A*B)+P)*F$
חלוקה	Divide	$C = ((A/B)+P)*F$
הגדול	Max of A or B	$C = ((\text{High value of channel A or B})+P)*F$
הקטן	Min of A or B	$C = ((\text{Low value of channel A or B})+P)*F$
גרע	Draw	$C = ((A/B)-1)*F$
מוצ"ט משוקלל	Weighted avg.	$C = ((B-A)*F)+A$
יחס	Ratio	$C = (A/B)*F$
יחס 2	Ratio 2	$C = ((B-A)/A)+P*F$
ריכוז	Concentration	$C = (A/(A+B))*F$
סכום כולל	Sum total	$C = (tA+tB+P)*F$
סכום כולל גדול	Sum grand total	$C = (GtA+GtB+P)*F$
דו"פ כולל	Diff. of total	$C = (tA-tB+P)*F$
דו"פ כולל גדול	Difference of grand total	$C = (GtA-GtB+P)*F$
יחס כולל	Total ratio	$C = (tA/tB)*F$
יחס כולל 2	Total ratio 2	$C = ((tB-tA)/tA)*F$
תפ"ת כולל	Total percent	$C = (tA/(tA+tB))*100$

Math Constants (קבועים)

The *Math Constants* menu is used to set the constants used in channel C math. The math functions include adder constant P, and factor constant F.

The *Adder* constant (P) may be set from -99.999 to 999.999.

The *Factor* constant (F) may be set from 0.001 to 999.999.

The chart on page 54 details the math functions that may be selected in the *Math Function* menu.

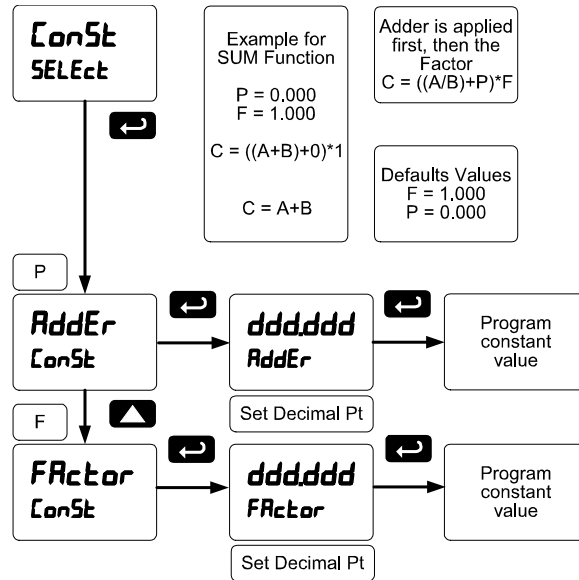

Low-Flow Cutoff (CutOff)

The low-flow cutoff feature allows the meter to be programmed so that the often-unsteady output from a differential pressure transmitter, at low flow rates, always displays zero on the meter. The low-flow cutoff for each channel is programmed independently.

The cutoff value may be programmed from 0 to 999999. The meter will display zero below the cutoff value. Programming the cutoff value to zero disables the cutoff feature.

Totalizer Count Up/Down (Count)

The totalizer count up/down menu may be used to program the total and grand total to either count up from 0 when reset or count down from a programmed value when reset. Total and grand total may have their countdown numbers programmed individually from 0 to 999999.

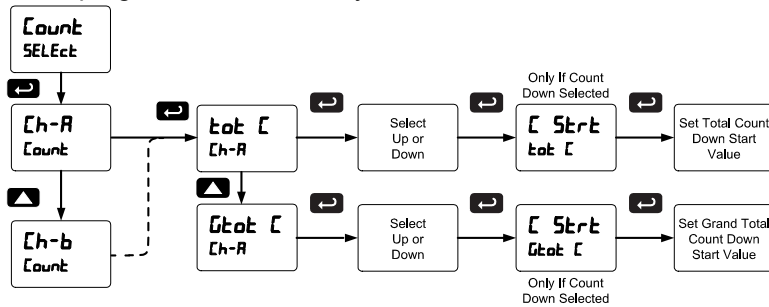

Analog Output Programming (OutPr)

The *Analog Output Programming* menu is used to program the behavior of the 4-20 mA outputs. The following parameters and functions are programmed in this menu for each analog output:

1. Source: Source for generating the 4-20 mA output
2. Overrange: Analog output value with display in overrange condition
3. Underrange: Analog output value with display in underrange condition
4. Max: Maximum analog output value allowed regardless of input
5. Min: Minimum analog output value allowed regardless of input

Analog Output Source

The analog output source can be based on either of the input channel rate, total, or grand totals (Ch-A, Ch-B), the math channel (Ch-C), maximum stored value of either input channel (Hi-A, Hi-B), minimum stored value of either input channel (Lo-A, Lo-B), maximum or minimum of A and B (Hi-AB, Lo-AB), relay set points, or the Modbus input.

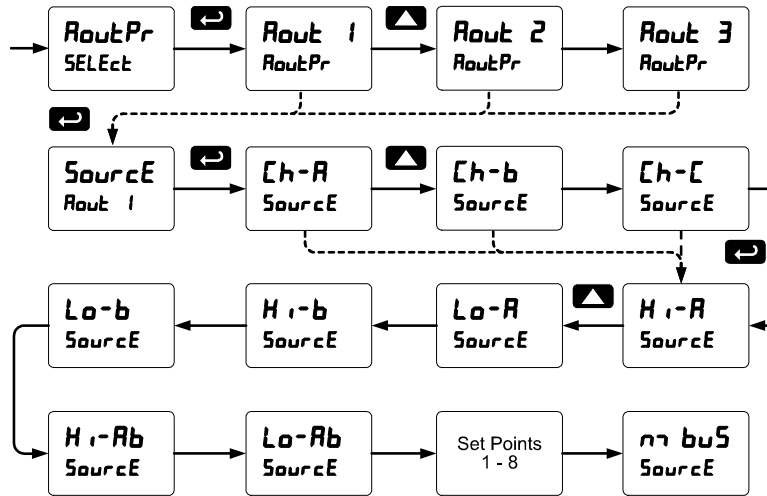

To base an analog output on the rate, total, or grand total of channels A or B, select the channel in the *Analog Output Source* menu. Then select the rate, total, or grand total as the source reference for the output, and program the output scale.

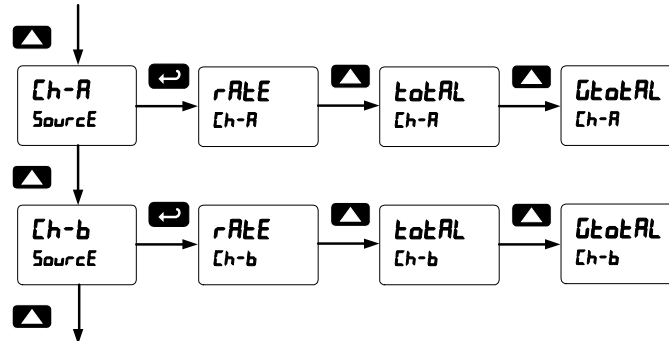

Programmable Function Keys User Menu (uSEr)

The *User* menu allows the user to assign the front panel function keys F1, F2, and F3, the digital input F4 (a digital input located on the signal input connector), and up to eight additional digital inputs to access most of the menus or to activate certain functions immediately (e.g. reset max & min, hold relay states, etc.). This allows the meter to be greatly customized for use in specialized applications.

Up to eight digital outputs can be assigned to a number of actions and functions executed by the meter (i.e. alarms, relay acknowledgement, reset max, min, or max & min, tare, and reset tare). The digital outputs can be used to trigger external alarms or lights to indicate these specific events.

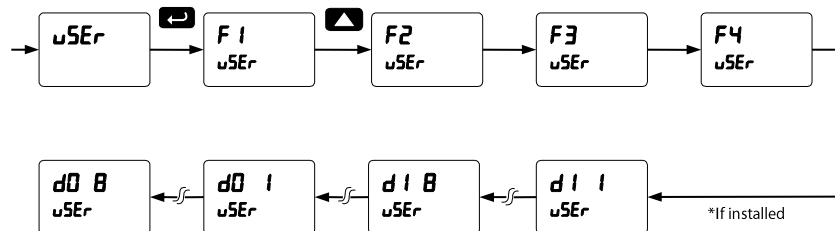

Function Keys & Digital I/O Available Settings

Refer to the following table for descriptions of each available function key or digital I/O setting.

Display	Description	Display	Description
r5t Hi	Reset the stored maximum display values for all channels	Ln2 Lo	Display minimum Channel B display value on line 2
r5t Lo	Reset the stored minimum display values for all channels	Ln2 Hl	Display maximum & minimum channel B display values on line 2
r5t Hl	Reset the stored maximum & minimum display values for all channels	Ln2 Hc	Display minimum channel C display value on line 2
rELRY	Directly access the relay menu	Ln2 Hc	Display maximum & minimum channel C display values on line 2
5Et I*	Directly access the set point menu for relay 1 (*through 8)	L tHLL	Display maximum channel C display value on line 2
rLY d	Disable all relays until a button assigned to <i>enable relays (rLY E)</i> is pressed	F On I*	Force relay 1 (*through 4) into the on state. This function is used in conjunction with a digital input to achieve interlock functionality. See page 45 for details about interlock relays.
rLY E	Enable all relays to function as they have been programmed	Control	Directly access the control menu
H Hold	Hold current relay states and analog output as they are until a button assigned to <i>enable relays (rLY E)</i> is pressed	d,SRbL	Disable the selected function key or digital I/O
d Hold	Hold the current display value, relay states, and analog output momentarily while the function key or digital input is active. The process value will continue to be calculated in the background.	uP-d R	Total count mode direction control for channel A
d RbL	Scrolls values for A, B & C when activated. Keeps the last value for 10 seconds and then it returns to its assignment. Values are displayed on display line 1 and the corresponding channel and units on display line 2.	uP-d b	Total count mode direction control for channel B
d tot	Scrolls through totals for channels A, B, and C (which is the sum of A and B). Values are displayed on display line 1.	RcH	Acknowledge all active relays that are in a manual operation mode such as auto-manual or latching
d Gtot	Scrolls through grand totals for channels A, B, and C (which is the sum of A and B). Values are displayed on display line 1.	rESEt	Directly access the reset menu
Ln1 Hi	Display maximum channel A display value on line 1	r5t t	Reset totals for all channels
Ln1 Lo	Display minimum channel A display value on line 1	r5t Gt	Reset grand totals for all channels
Ln1 Hl	Display maximum & minimum channel A display values on line 1	r5t tR	Reset total for channel A
Ln2 Hi	Display maximum channel B display value on line 2	r5t GR	Reset grand total for channel A
		r5t tb	Reset total for channel B
		r5t Gb	Reset grand total for channel B
		nREn	Mimic the menu button functionality (digital inputs only)
		rGHt	Mimic the right arrow/F1 button functionality (digital inputs only)
		uP	Mimic the up arrow/F2 button functionality (digital inputs only)
		EntEr	Mimic the enter/F3 button functionality (digital inputs only)
		RLn r I*	Provide indication when alarm 1 (*through 8) has been triggered (digital outputs only)

Meter Operation

The meter accepts two input channels (A and B) of either pulses (e.g. ± 40 mV to ± 8 V), square wave (0-5 V, 0-12 V, or 0-24 V), open collector NPN, PNP, TTL, or switch contact signals and displays these signals in engineering units from -99999 to 999999. (e.g. a 0-1000 Hz signal could be displayed as -50.000 to 50.000).

Digital inputs and quadrature inputs can be accepted for bi-directional flow on channel A and B. Quadrature inputs can also be accepted, using channels A and B to calculate a single bi-directional flow.









A totalizer can be programmed to count the scaled engineering units, interpreting it as count per second, minute, hour, or day. The scaled rate and total for each channel can be displayed on the top or bottom displays.

A math function channel (C) is available to perform operations on channel A and B rates or totals, with adder and factor constants, and display the results. Engineering units or tags may be displayed with these three channels.

The dual-line display can be customized by the user. Typically, display line 1 is used to display the math channel C, while line 2 is used to alternate between displaying input channels A and B rate or total.

Additionally, the meter can be set up to display any input or math channel on display line 1 and a unit or tag on line 2. The relays and analog output can be programmed to operate based on any input rate or total, or the math function channel.

Front Buttons Operation

Button Symbol	Description
 or 	Press to enter or exit Programming Mode, view settings, or exit max/min readings
 or 	Press to reset max/min readings or other parameter/function assigned through the <i>User</i> menu
 or 	Press to display max/min readings for channel A or other parameter/function assigned through the <i>User</i> menu
 or 	Press to acknowledge relays or other parameters/function assigned through the <i>User</i> menu

SafeTouch[®] Buttons

The ProtEX-MAX is equipped with four sensors that operate as through-glass buttons so that it can be programmed and operated without removing the cover (and exposing the electronics) in a hazardous area.

These buttons can be disabled for security by selecting DISABLE on the switch labeled NO-CONTACT BUTTONS located on the connector board.

To actuate a button, press one finger to the glass directly over the marked button area. Then retract finger more than three inches from the glass before pressing the next button. When the cover is removed, the four mechanical buttons located next to the sensors are used. The sensors are disabled when a mechanical button is pressed and will automatically be re-enabled after 60 seconds of inactivity.

The SafeTouch Buttons are designed to filter normal levels of ambient interference and to protect against false triggering, however, it is recommended that the SafeTouch Buttons be disabled (slide switch to LOCK) if there is an infrared interference source in line-of-sight to the display.

The SafeTouch Buttons are configured by default to duplicate the function of the front panel mechanical pushbuttons associated with the integrated meter. The symbols by each SafeTouch button correspond to a mechanical button as shown in the above table.

SafeTouch Button Tips:

- To the extent possible, install the display facing away from sunlight, windows, reflective objects and any sources of infrared interference.
- Keep the glass window clean.
- Tighten the cover securely.
- Use a password to prevent tampering.

 WARNING	<p>Take caution when cleaning the window glass as it may result in unintentional SafeTouch button events. Only clean the ProtEX-MAX when the system is safely shut down, and inspect the ProtEX-MAX for proper configuration prior to system restart.</p>
---	---

F4 Operation

A digital input, F4, is standard on the meter. This digital input is programmed identically to function keys F1, F2, and F3. The input is triggered with a contact closure to COM, or with an active low signal. During operation, F4 operates according to the way it has been programmed in the *Advanced Features – User* menu.

Maximum/Minimum Readings

The max & min readings (peak & valley) reached by the process can be displayed either continuously or momentary:

1. Display briefly by assigning to the F1-F3 function keys or to the digital inputs in the *User* menu.
2. Display continuously by assigning either display to max/min through the *Display* menu.

Any of the F1-F3 function keys (buttons) and the digital inputs can be programmed to reset the max & min readings. The meters are set at the factory to display the max/min reading by pressing the Up arrow/F2 button and to use the Right arrow/F1 button to reset the max/min.

To display max and min channel A reading using function key with factory defaults:

1. Press Up arrow/F2 button to display the maximum and minimum reading of channel A since the last reset/power-up.
2. To reset max/min press Right arrow/F1 button. The max & min displays are reset to actual values.
3. Press Menu to exit max/min display reading.

Troubleshooting

The rugged design and the user-friendly interface of the meter should make it unusual for the installer or operator to refer to this section of the manual. However, due to the many features and functions of the meter, it's possible that the setup of the meter does not agree with what an operator expects to see. If the meter is not working as expected, refer to the *Diagnostics* menu and recommendations below.

Diagnostics Menu (d ,RG)

The *Diagnostics* menu is located in the *Advanced Features* menu. To access the *Diagnostics* menu see *Advanced Features Menu*, page 48.

For a description of the diagnostic messages, see *Advanced Features Menu & Display Messages*, page 48.

Determining Software Version

To determine the software version of a meter:

1. Go to the *Diagnostics* menu (d ,RG) and press Enter button.
2. Press Up arrow button and scroll to Information menu (inF0).
3. Press Enter to access the software number (5Ft) and version (UER) information. Write down the information as it is displayed. Continue pressing Enter until all the information is displayed.
4. The meter returns to Run Mode after displaying all the settings.

Reset Meter to Factory Defaults

When the parameters have been changed in a way that is difficult to determine what's happening, it might be better to start the setup process from the factory defaults.

Instructions to load factory defaults:

1. Enter the *Advanced Features* menu. See *Advanced Features Menu*, page 48.
2. Press Up arrow to go to *Diagnostics* menu
3. Press and hold Right arrow for three seconds, press Enter when display flashes rESEt.
Note: If Enter is not pressed within three seconds, the display returns to Run Mode.
4. The meter goes through an initialization sequence (similar as on power-up), and loads the factory default settings.

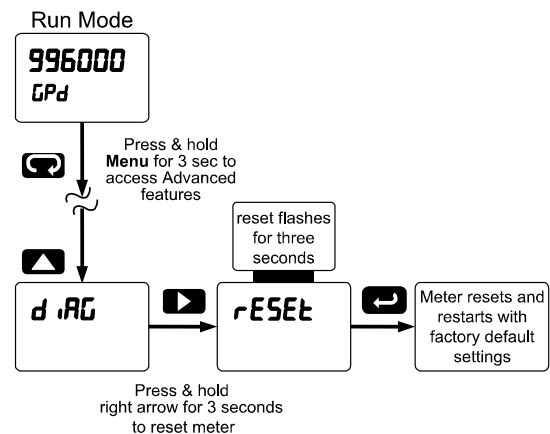

Factory Defaults & User Settings

The following table shows the factory setting for most of the programmable parameters on the meter.

Parameter	Display	Default Setting
Input type	INPUL	
Total, channel A	CH-R	Yes
Total, channel B	CH-b	Yes
Units	UNITS	
Rate unit, channel A	CH-R	HZ-A
Rate unit, channel B	CH-b	HZ-b
Unit, channel C	CH-C	HZ-C
Total unit, channel A	tot-R	tot-A
Grand total unit, ch-A	Gtot-R	Gtot-A
Total unit, channel B	tot-b	tot-b
Grand total unit, ch-B	Gtot-b	Gtot-B
Decimal Point	DEC Pt	
Rate, channel A	RATE	1
Total, channel A	totRL	1
Grand total, channel A	GtotRL	0
Rate, channel B	RATE	1
Total, channel B	totRL	1
Grand total, channel B	GtotRL	0
Channel C	CH-C	1
Input Calibration	INCR	
Number of points	no Pts	
Number of points, ch-A	CH-R	2
Number of points, ch-B	CH-b	2
K-Factor, channel A	FRct-R	1.000
K-Factor, channel B	FRct-b	1.000
Total setup	tSEtUP	
Time base, channel A	tbRSE	Sec
Total conversion factor, Ch-A	t CF	1.000
Grand total conversion factor, Ch-A	Gt CF	1.000
Time base, channel B	tbRSE	Sec

Parameter	Display	Default Setting
Total conversion factor, Ch-B	t CF	1.000
Grand total conversion factor, Ch-B	Gt CF	1.000
Total reset	trESEt	
Total reset, channel A	t rSt	Manual
Grand total reset, Ch-A	Gt rSt	Manual
Total reset, channel B	t rSt	Manual
Grand total reset, Ch-B	Gt rSt	Manual
Display assignment	dSPLRy	
Display line 1	d CH-R	Channel A
Display line 2	d CH-b	Channel B
Display intensity	d- IntY	8
Relay	rELAY	
Relay 1 assignment	CH-R	Channel A total
Relay 1 action	Rct 1	Automatic
Relay 1 set point	SEt 1	100.0
Relay 2 assignment	CH-R	Channel A total
Relay 2 action	Rct 2	Automatic
Relay 2 set point	SEt 2	200.0
Relay 3 assignment	CH-R	Channel A rate
Relay 3 action	Rct 3	Automatic
Relay 3 set point	SEt 3	300.0
Relay 3 reset point	rSt 3	250.0
Relay 4 assignment	CH-R	Channel A rate
Relay 4 action	Rct 4	Automatic
Relay 4 set point	SEt 4	400.0
Relay 4 reset point	rSt 4	350.0
Fail-safe relay 1 to 4	FLS 1	Off
On delay relay 1 to 4	On 1	0.0 sec
Off delay relay 1 to 4	OFF 1	0.0 sec
Analog output	AOuT	
Display 1 analog out	d ,S 1	0.0
Output 1 value	Out 1	4.000 mA
Display 2 analog out	d ,S 2	1000.0

Parameter	Display	Default Setting
Output 2 value	Out 2	20.000 mA
Source analog output	Source	Channel A
Overrange output	OverRng	21.000 mA
Underrange output	UnderRng	3.000 mA
Maximum output	Max RH	23.000 mA
Minimum output	Min in	3.000 mA
Filter	Filter	
Filter, channel A	Ch-A	High speed
Filter, channel B	Ch-b	High speed
Round	round	1
Cutoff	Cutoff	
Cutoff value, channel A	Ch-A	0.0 (disabled)
Cutoff value, channel B	Ch-b	0.0 (disabled)
Serial	Serial	
Slave ID (Address)	Slave ID	247
Baud rate	Baud	9600
Transmit delay	Tr Delay	50 ms
Parity	Parity	Even
Byte-to-byte timeout	Byte-to-byte	010 (0.1 sec)
Math	Math	
Math, channel C	Sum	Sum
Adder (constant P)	Adder	0.000
Factor (constant F)	Factor	1

Parameter	Display	Default Setting
User	User	
F1 function key	F1	Reset max & min
F2 function key	F2	Line 1 Max & Min
F3 function key	F3	Acknowledge relays
F4 function (digital input)	F4	Acknowledge relays
Digital input 1	di 1	Menu
Digital input 2	di 2	Right arrow
Digital input 3	di 3	Up arrow
Digital input 4	di 4	Enter
Digital output 1	do 1	Alarm 1
Digital output 2	do 2	Alarm 2
Digital output 3	do 3	Alarm 3
Digital output 4	do 4	Alarm 4
Password	Pass	
Password 1	Pass 1	000000 (unlocked)
Password 2	Pass 2	000000 (unlocked)
Password 3	Pass 3	000000 (unlocked)
Total	Total	000000 (unlocked)
Grand total	Grand Total	000000 (unlocked)

Troubleshooting Tips

Symptom	Check/Action
SafeTouch buttons do not respond	<p>If mechanical button was pushed. The SafeTouch buttons will be re-enabled automatically 60 seconds after the last button push.</p> <p>If slide switch on connector board is in DISABLE position, switch to ENABLE.</p> <p>Strong direct sunlight may interfere with SafeTouch button operation. It is recommended to operate the buttons by standing so as to block direct sunlight.</p>
Serial Communications Power LED Indicator is off	<ol style="list-style-type: none"> 1. Check modular cable connection 2. Check power to the device
If only the TX (or DATA IN) data status LED is flashing when serial communications attempted	<ol style="list-style-type: none"> 1. Check serial cable 2. Check protocol selected on device 3. Check instrument address & baud rate 4. Check program address & baud rate

Symptom	Check/Action
If both data status LEDs (TX and RX) are off when trying to communicate	Remove all unnecessary cables and instruments from the bus. Try getting the system to work with only one device (to ease troubleshooting) and then expand the system one device at a time.
Communications slow	Increase the baud rate
Random communication errors	<ol style="list-style-type: none"> Increase the TX delay time Decrease the baud rate
Power LED is off	<ol style="list-style-type: none"> Check modular cable connection Check power to instrument
No display at all	Check power at power connector
Not able to change setup or programming, <i>L o c d</i> is displayed	Meter is password-protected, enter correct six-digit password to unlock
Meter displays error message during calibration (<i>E r r o r</i>)	<p>Check:</p> <ol style="list-style-type: none"> Signal connections Input selected in <i>Setup</i> menu Minimum input span requirements
Meter displays <ol style="list-style-type: none"> 999999 -99999 	<p>Check:</p> <ol style="list-style-type: none"> Input selected in <i>Setup</i> menu Corresponding signal at Signal connector
Display is unstable	<p>Check:</p> <ol style="list-style-type: none"> Input signal stability and value Display scaling vs. input signal Filter and bypass values (increase)
Display response is too slow	Check filter and gate values
Display reading is not accurate	<p>Check:</p> <ol style="list-style-type: none"> Proper input programming used (k-factor, scaling, calibration)
Display does not respond to input changes, reading a fixed number	<p>Check:</p> <ol style="list-style-type: none"> Display assignment, it might be displaying max, min, or set point.
Display alternates between <ol style="list-style-type: none"> <i>H i</i> and a number <i>L o</i> and a number 	Press Menu to exit max/min display readings.
Relay operation is reversed	<p>Check:</p> <ol style="list-style-type: none"> Fail-safe in <i>Setup</i> menu Wiring of relay contacts
Relay and status LED do not respond to signal	<p>Check:</p> <ol style="list-style-type: none"> Relay action in <i>Setup</i> menu Set and reset points
Flashing relay status LEDs	Relays in manual control mode or relay interlock switches opened.
Meter not communicating with application programs	<p>Check:</p> <ol style="list-style-type: none"> Serial adapter and cable Serial settings Meter address and baud rate
If the display locks up or the meter does not respond at all	Cycle the power to reboot the microprocessor.
Other symptoms not described above	Call Technical Support for assistance.

Service



WARNINGS

- Installation and service should be performed only by trained service personnel. Service requiring replacement of internal sub-components must be performed at the factory.
- Disconnect from supply before opening enclosure. Keep cover tight while circuits are alive. Conduit seals must be installed within 18" (450mm) of the enclosure.
- Verify that the operating atmosphere of the instrument is consistent with the appropriate hazardous locations certifications.
- If the instrument is installed in a high voltage environment and a fault or installation error occurs, high voltage may be present on any lead
- Read all product labels completely and follow all instructions and requirements listed on the labels for installation or service.

If the enclosure is sound and undamaged, then only the internal electronics housing will need to be returned to the factory for service. Contact the factory for RMA number and return instructions.

Mounting Dimensions

All units: inches (mm)

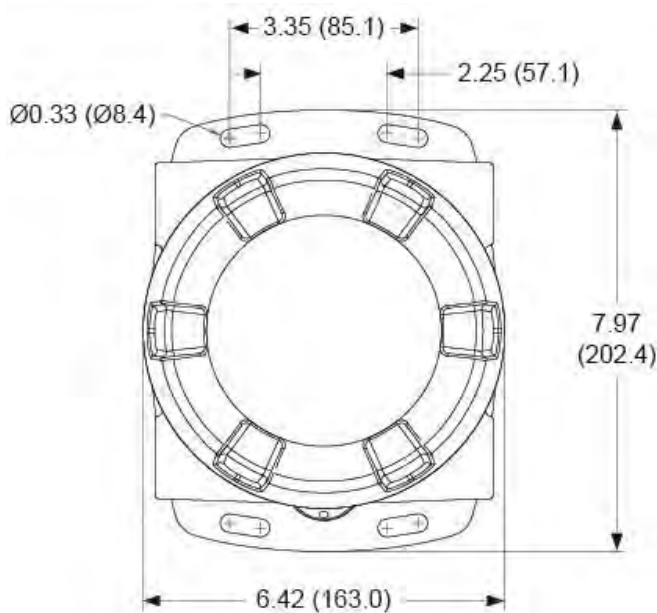

Figure 31: Enclosure Dimensions – Front View

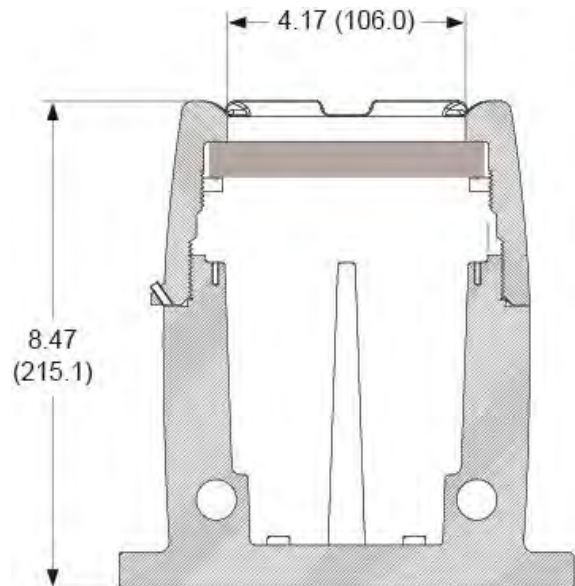

Figure 32: Enclosure Dimensions – Side Cross Section View

EU Declaration of Conformity

Issued in accordance with ISO/IEC 17050-1:2004 and ATEX Directive 2014/34/EU.

We,

Precision Digital Corporation
233 South Street
Hopkinton, MA 01748 USA

as the manufacturer, declare under our sole responsibility that the product(s),

Model PD8 ProtEX-MAX Series

to which this declaration relates, is in conformity with the European Union Directives shown below:

2014/35/EU	Low Voltage Directive
2014/34/EU	ATEX Directive
2014/30/EU	EMC Directive
2011/65/EU	RoHS Directive

This conformity is based on compliance with the application of harmonized or applicable technical standards and, when applicable or required, a European Union notified body certification.

Standards:

EN 55022:2007	EN 61000-6-2:2005	EN 60079-0:2009	EN 61000-6-4:2007
EN 60079-1:2007	EN 61010-1:2001	EN 60079-31:2008	EN 61326:2006

The standards EN 55022:2007, EN 60079-0:2009, EN 60079-1:2007, EN 60079-31:2008, EN 61000-6-4:2007, EN 61010-1:2001, and EN 61326:2006 are no longer harmonized. The requirements of these standards have been checked against the harmonized standard EN 55022:2010, EN 60079-0:2012+A11:2013, EN 60079-1:2014, EN 60079-31:2014, EN 61000-6-4:2007+A1:2011, EN 61010-1:2010, and EN 61326:2013 and there were no major technical changes affecting the latest technical knowledge for the products listed above.

EC Type Examination Certificate: Sira 12ATEX1182

Product Markings:

 II 2 G D
Ex d IIC T* Gb
Ex tb IIIC T90°C Db IP68
Tamb = -40°C to +*°C (*T5 = 65°C, *T6 = 60°C)

ATEX Notified Body for EC Type Examination Certificate: Sira Certification Service, NB 0518
Unit 6, Hawarden Industrial Park
Hawarden, Deeside, CH5 3US, UK

ATEX Quality Assurance Notification No.: SIRA 10 ATEX M462

ATEX Notified Body for Quality Assurance: Sira Certification Service, NB 0518
Unit 6, Hawarden Industrial Park
Hawarden, Deeside, CH5 3US, UK

Signed for and on behalf of Precision Digital Corporation:



Name: Jeffrey Peters
Company: Precision Digital Corporation
Title: President
Date: 02/12/2018



Document No: DoC PD8 {021218}

How to Contact Precision Digital

- For Technical Support, please
Call: (800) 610-5239 or (508) 655-7300
Fax: (508) 655-8990
Email: support@predig.com
- For Sales Support or to place an order, please contact your local distributor or
Call: (800) 343-1001 or (508) 655-7300
Fax: (508) 655-8990
Email: sales@predig.com
- For the latest version of this manual, please visit
www.predig.com

PRECISION DIGITAL CORPORATION

233 South Street • Hopkinton MA 01748 USA
Tel (800) 343-1001 • Fax (508) 655-8990



www.predig.com