

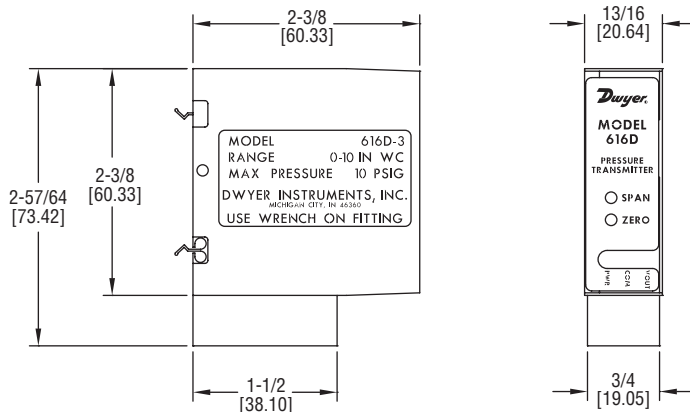

Series 616D DIN Rail Differential Pressure Transmitter

Specifications - Installation and Operating Instructions



The **SERIES 616D** DIN Rail Differential Pressure Transmitter senses the pressure of air and compatible gases and sends a standard 4 to 20 mA or 0 to 10 VDC output signal. The 616D housing is specifically designed to mount on a 35 mm DIN rail in a panel. This mounting style allows for several units to be mounted closely together reducing required space. The span and zero controls are for use when checking calibration, and are not intended for re-arranging to a significantly different span. Versatile circuit design enables operation in 2-wire current loops.

INSTALLATION

- 1. Location:** Select a clean, dry mounting location free from excess vibration where the temperature will remain between 14 and 185°F (-10 to 85°C). Distance from the receiver is limited only by total loop resistance. See electrical connections in Figure 1. The tubing supplying pressure to the instrument can be practically any length required, but long lengths will increase response time slowly.
- 2. Position:** A vertical position, with pressure connections pointing down, is recommended. That is the position in which all standard models are spanned and zeroed at the factory. They can be used at other angles, but final spanning and zeroing must be done while the transmitter is in that alternative position.
- 3. Pressure Connections:** Two installable barbed tubing connections are provided. They are dual-sized to fit both 1/8" and 3/16" (3.12 and 4.76 mm) I.D. tubing. Be sure the pressure rating of the tubing exceeds that of the operating ranges.

SPECIFICATIONS	
Service:	Air and non-combustible, compatible gases.
Wetted Materials:	Consult factory.
Accuracy:	±0.25 FS @ 77°F (25°C).
Thermal Effect:	±0.02% FS/°F (±0.036% FS/°C).
Stability:	±1% FS/yr.
Temperature Limits:	14 to 185°F (-10 to 85°C).
Pressure Limits:	See chart.
Power Requirements:	10 to 35 VDC (2-wire), 17 to 36 VDC, or isolated 21.6 to 33 VAC (3-wire).
Output Signal:	4 to 20 mA (2-wire) or 0 to 10 VDC (3-wire).
Zero and Span Adjustments:	Push buttons.
Loop Resistance:	Current output: 0 to 1250 Ω (max); Voltage output: Load resistance 1 kΩ (min).
Current Consumption:	40 mA max.
Electrical Connections:	Screw-type terminal block.
Process Connections:	1/8" female NPT. Accessories included are 2 barbed fittings for 1/8" and 3/16" (3.12 and 4.76 mm) I.D. rubber and vinyl tubing.
Mounting Orientation:	Vertical, on a 1.378 (35 mm) DIN rail.
Weight:	4.8 oz (136 g).
Agency Approvals:	CE.

Series 616D Transmitter Models & Ranges

MODEL CHART		
Model	Range	Max. Pressure
616D-2	0 to 6 in w.c.	10 psig
616D-3	0 to 10 in w.c.	10 psig
616D-4	0 to 20 in w.c.	20 psig
616D-5	0 to 40 in w.c.	20 psig
616D-6	0 to 100 in w.c.	15 psig
616D-7	0 to 200 in w.c.	45 psig
616D-8	0 to 10 psid	45 psig

Table 1

ELECTRICAL CONNECTIONS

CAUTION Do not exceed specified supply voltage ratings. Permanent damage not covered by warranty will result. This unit is not designed for 120 or 240 VAC line operation.

Electrical Connections are made to the terminal block located in front of the transmitter. Terminals are marked PWR, COM, and VOUT. (See Figure 1 below)

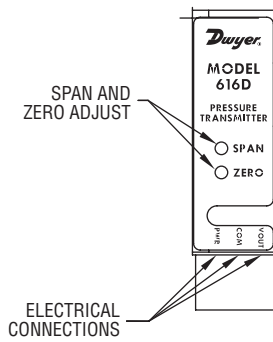

Figure 1: Electrical Connections

Electrical Connection:

The Series 616D simultaneously transmits a 2-wire 4 to 20 mA current output and a 3-wire 0 to 10 V voltage output via a screw-type terminal block. The transmitter can be wired in one of the following three ways to utilize the current and/or voltage output.

Power Supply

Refer to Table 2 for the required supply rating.

MODEL CHART	
Output Type	Power Supply Rating
2-wire current	10 to 35 VDC (40 mA min)
3-wire voltage	17 to 36 VDC or 21.6 to 33 VAC (40 mA min)
Simultaneous current and voltage	17 to 35 VDC (40 mA min)

Table 2

Choose a power supply with a voltage and current rating sufficient to meet the power specifications under all operating conditions. If the supply is unregulated, make sure that the output voltage remains within the required voltage range under all power line conditions. Ripple on the supply should not exceed 100 mV.

2-Wire 4 to 20 mA Current Operation

CAUTION Do not exceed specified supply voltage ratings. Permanent damage not covered by warranty will result. Simultaneous outputs are not designed for AC voltage operation.

The connections to the transmitter are made through terminals PWR and COM on the terminal block as shown in Figure 2.

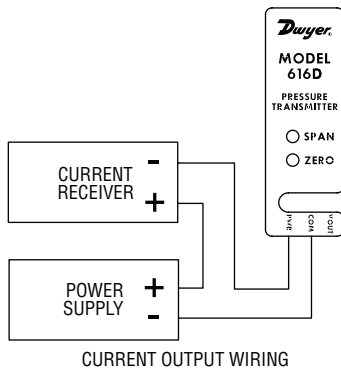

Figure 2: Current Output Wiring

The range of appropriate receiver load resistances (RL) for power supply voltage available is given by the formula listed below. Shielded 2-wire cable is recommended for control loop wiring. Ground the shield at the power supply end.

NOTICE The receiver may be connected to either the negative or positive side of the loop, whichever is most convenient. Should the polarity of the transmitter or receiver be inadvertently reversed, the loop will not function properly, but no damage will be done to the transmitter.

$$R_L = \frac{V_{PS} - 10.0}{20 \text{ mA DC}}$$

The maximum length of connecting wire between the transmitter and the receiver is a function of wire size and receiver resistance. That portion of the total current loop resistance represented by the resistance of the connecting wires themselves should not exceed 10% of the receiver resistance. For extremely long runs (over 1,000 ft/305 m), it is desirable to select receivers with lower resistances in order to keep the size and cost of the connecting leads as low as possible. In installations where the connecting run is no more than 100 ft (30.5 m), connecting lead wire as small as No. 22 ga. can be used.

3-Wire 0 to 10 V Voltage Operation

CAUTION Do not exceed specified supply voltage ratings. Permanent damage not covered by warranty will result.

The connections to the transmitter are made to Terminals PWR, COM, and VOUT on the terminal block as shown in Figure 3.

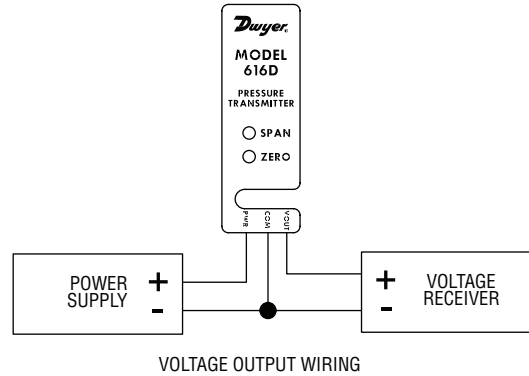

Figure 3: Voltage Output Wiring

The minimum receiver load is 1 kΩ. The resistance due to the wire should be low compared to the receiver load resistance. While the voltage at the terminal block remains unchanged with a 10 mA current flow, resistive losses in the wiring do cause errors in the voltage delivered to the receiver. For a 1% accuracy gauge, the resistance of the wires should be less than 0.1% of the value of the receiver load resistance. This will keep the error caused by the current flow below 0.1%.

Simultaneous Current and Voltage Operation

CAUTION

Do not exceed specified supply voltage ratings. Permanent damage not covered by warranty will result. Simultaneous outputs are not designed for AC voltage operation.

The connections to the transmitter are made to Terminals PWR, COM, and VOUT on the terminal block as shown in Figure 4. The voltage output and the power supply must have separate wire leads that are only joined at terminal COM of the transmitter. Additional error may occur for the voltage output if a single wire is used or if the wires are joined at the power supply or receiver.

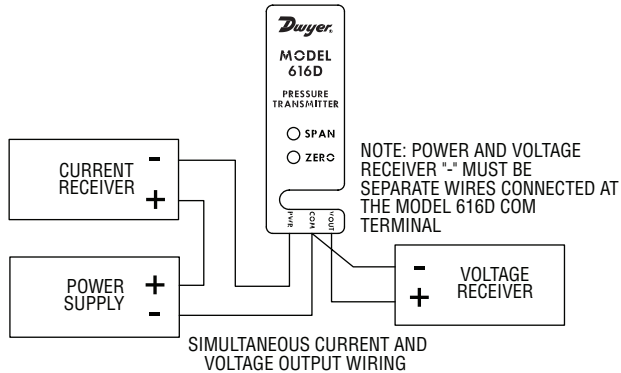

Figure 4: Simultaneous Current and Voltage Output Wiring

For the current output, the maximum allowable loop resistance (wiring + receiver resistance) is dependent on the power supply. The maximum loop voltage drop must not reduce the transmitter voltage below 17 V. The maximum loop resistance can be calculated using the following equation:

$$R_{MAX} = \frac{V_{PS} - 17.0}{20 \text{ mA DC}}$$

(where V_{PS} is the power supply voltage)

The equation uses 17.0 instead of 10.0 used in the current only equation. This represents the minimum voltage supply which is higher on the simultaneous output configuration due to the requirements of the voltage outputs.

Shielded 4-wire cable is recommended for control loop wiring. Ground the shield at the power supply end only. Should the polarity of the transmitter or receiver be inadvertently reversed, the unit will not function properly, but no damage will be done to the transmitter.

For voltage outputs, the minimum receiver load is 1 k Ω . The resistance due to the wire should be low compared to the receiver load resistance. While the voltage at the terminal block remains unchanged with a 10 mA current flow, resistive losses in the wiring do cause errors in the voltage delivered to the receiver. For a 1% accuracy gauge, the resistance of the wires should be less than 0.1% of the value of the receiver load resistance. This will keep the error caused by the current flow below 0.1%.

CALIBRATION

NOTICE

There is a 5 second delay from the time the zero or span calibration button is released until the time that the change in the calibration takes place. This delay is used to prevent stress related offsets on the lower range.

Zero Calibration

The zero calibration can be set by applying zero pressure to both the pressure ports and pressing the zero button for 3 seconds.

Span Calibration

The span calibration can be adjusted only after setting the zero adjustment. It must be completed within 5 minutes of the last zero calibration. The span calibration button will be ignored until the zero calibration is completed. Apply pressure to the ports of the transmitter that are associated with the maximum output of the transmitter (20 mA, 5 V, or 10 V, depending on the output being used). Press and hold the span button for 3 seconds.

MULTIPLE RECEIVER INSTALLATION

An advantage of the standard 4 to 20 mA DC output signal produced by the Series 616D Transmitter is that any number of receivers can be connected in series in the current loop, given max loop total resistance is not violated. Thus an analog panel meter, a chart recorder, process controlling equipment, or any combination of these devices can be operated simultaneously. The only requirement is that each component be equipped for a standard 4 to 20 mA input and the proper polarity of the input connections be observed when inserting the device in the current loop. If any of the units display a negative or downscale reading, the signal input leads are reversed.

ZERO DEADBAND

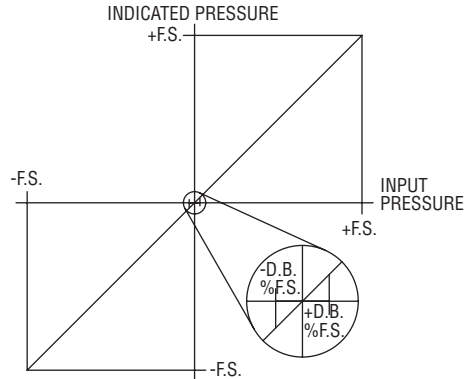

Figure 4

MAINTENANCE/REPAIR

Upon final installation of the Series 616D DIN Rail Differential Pressure Transmitter, no routine maintenance is required. The Series 616D is not field serviceable and is not possible to repair the unit. Field repair should not be attempted and may void warranty.

WARRANTY/RETURN

Refer to "Terms and Conditions of Sale" in our catalog and on our website. Contact customer service to receive a Return Goods Authorization number before shipping the product back for repair. Be sure to include a brief description of the problem plus any additional application notes.

