

## MODEL 114D

### FEATURES

- One or Two Stage Valve Control
- Fully Programmable
- Displays Batch Total, Accumulated Total and Preset
- Panel, Wall and Pipe Mounting
- Watertight to IP67 (Nema 4X)
- CE Compliant

DC POWERED

## Batch Controller



The 114D Batch Controller is designed for flow applications where the precise control of batch quantities is required. Batch Total, Accumulated Total and Preset values can all be displayed on the large LCD display.



# Field Mounting Batch Controller

PROVEN IN THOUSANDS OF FIELD INSTALLATIONS THROUGHOUT THE WORLD.

The 114D is a high accuracy Batch Controller designed to operate with digital output flowmeters. Having an IP67 weatherproof case, tactile keyboard and various mounting options, makes it a very versatile unit.

The 114D has an input conditioning circuit which will accept pulse or frequency flow signals.

The controller will operate from an external power source between 9 and 28 Volts and draws no more than 4mA.

Lithium batteries provide backup if the DC power to the controller is interrupted so that totals are not lost.

Solid state outputs provide control to solenoids and relays, and can sink up to 200mA.

The controller is housed in a rugged, yet attractive, IP67 (Nema 4X) polycarbonate enclosure which is completely watertight. A wall mounting bracket (no gland holes) is supplied as standard, while panel and pipe mounting brackets are available as options.

## DIMENSIONS

### Overall Sizes

151mm (5.9") width  
98mm (3.9") height  
43mm (1.3") depth

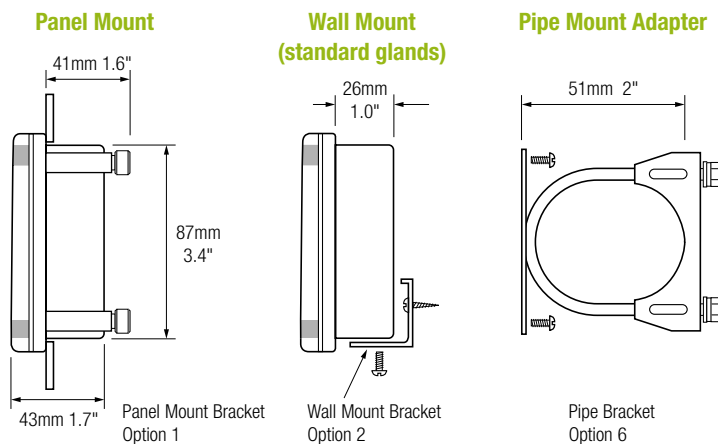

## TERMINAL DESCRIPTIONS

Terminal Inputs & Outputs	
Number	
1	DC Power 0 Volts
2	DC Power 9-28 Vdc
3	Output 1 (-)
4	Output 1 (+)
5	Output 2 (-)
6	Output 2 (+)
7	Signal Input (-)
8	Signal Input (+)

## PRODUCT CODES

Product Code & Mounting Types		
114D	•	Batch Controller
Enclosure Mounting	0	Wall Mounting (no gland holes)
	1	Panel Mount Brackets
	2	Wall Mounting (standard glands)
	6	Pipe Mount Adapter

Typical Part Number: 114D .2

## GENERAL SPECIFICATIONS

### Operating

**Temperature Limits:** -20 to +60°C, -4 to +140°F

### Enclosure

**Cable Entry:** By cable gland  
**Materials:** Polycarbonate and ABS

### Display

**Batch Total:** 7 digit 10mm (0.4") high LCD (continuously powered). *Note: The Accumulated Total is displayed when the ACCUM TOT key is pressed*

**Preset:** 5 digit 8.5mm (0.33") high LCD (continuously powered)

**K-factor Range:** The pulses per unit of measure (eg.pulses/gallon) is programmable in the range 0.000001 to 999,999

**Decimal Points:** Fully programmable for Rate and Total

**Time Base:** Rates can be displayed in units per second, minute, hour or day

**Frequency Range:** 0.01Hz to 10kHz

**Signal Type:** Switch settable for sine wave (15mV P-P minimum), open collector, reed switch or pulse

**Interference:** CE compliance

### Relay Outputs

**Type:** 2 x solid state relay outputs suitable for driving DC solenoids or external relays. The outputs provide for one or two stage control of the flow

**Switching Power:** 200mA, 30V dc maximum

**Saturation Voltage:** 0.8V dc across outputs when

### Battery

**Type:** 2 x Lithium batteries

**Battery Life:** 2 years

## Instruments within the Contrec family:

**100 Series** – Accurate process instruments for field mounting applications

**200 Series** – Intrinsically safe, precise and reliable process instruments

**400 Series** – Rugged and dependable batch and flow control solutions

**505 Series** – Next generation flow instruments for a variety of applications

**515 Series** – Precise flow and batch control for more complex applications

**1000 Series** – Robust load computers for petroleum and chemical applications

**TRAC 40** – Vehicle mount custody transfer approved registers



**Contrec Manufacturing (UK) Ltd**  
Riverside, Canal Road  
Sowerby Bridge  
West Yorkshire HX6 2AY

**t** +44 (0)1422 829944  
**f** +44 (0)1422 829945  
**e** admin@contrec.co.uk  
**w** www.contrec.co.uk

**SALES & TECHNICAL SUPPORT:**  
**+44 (0)1422 829944**  
**www.contrec.co.uk**

**Contrec Manufacturing Ltd**  
Manufacturing and Asia Sales:  
+44 (0)1422 829944  
admin@contrec.co.uk

**Contrec Europe Ltd**  
European, Middle East and Africa  
Sales: +44 (0)1422 829940  
sales@contrec.co.uk

**Contrec – USA**  
Americas & Canada Sales:  
+1 (0)205 685 3000  
customerservice@contrec-usa.com

**Contrec Systems PTY Ltd**  
Australasia Sales and South East Asia  
Support: +61 (0)413 505 114  
paul@contrec.com.au