

Application BC01

Dual Stage Batch Controller

for Volumetric Frequency or Analog Flowmeters



Features

- Caters for volumetric flow inputs from frequency or analog flowmeters
- Single or Dual stage control
- Quick access to common batch quantities
- No-flow, leakage and overflow error detection
- Remote RUN/STOP/RESET & BATCH SET functions
- Allows for square law and non-linear correction of flow input
- Storage of 1000 transactions with time and date stamp
- Selection of Detail or Basic main menu to suit operator and application
- Available protocols on communication ports including Printers, Modbus RTU & TCP/IP

Overview

The 515 BC01 application is a dual stage batch controller for reliable measurement of preset quantities using a volumetric frequency or analog input. Used as a single or dual stage controller it is suitable for fast batch applications.

It provides the operator with clear local readout and can be controlled via communications in more automated systems. There is quick access to commonly used preset values directly from the front panel if access has been authorized. Overrun compensation caters for system delays such as valve closure for precise quantities.

The instrument is compatible with a wide range of flowmeter outputs, including millivolt signals, reed switches, pulse, Namur proximity switches and analog signals. Inputs can be scaled, filtered and have non-linear correction applied. Square law and cutoff points can also be applied to the analog input.

Calculations

If using the frequency input, the total and flowrate are derived from accurately measured frequency and the number of received pulses.

$$volume = pulses / k\text{-factor}$$

$$volume\ flow = frequency / k\text{-factor}$$

If using the analog input, to derive the flow rate the input is normalised to a value (A) between 0 and 1.

$$volumeflow = (V_f\max - V_f\min)A + V_f\min$$

$$volume = \int (volumeflow \cdot \Delta t)$$

Automatic overrun compensation calculates the new valve closure point to ensure correct delivery by averaging the overrun amount from the last three complete batches.

The overrun compensation value is valid for a new preset value provided the stored overrun is less than 20% of the new preset.

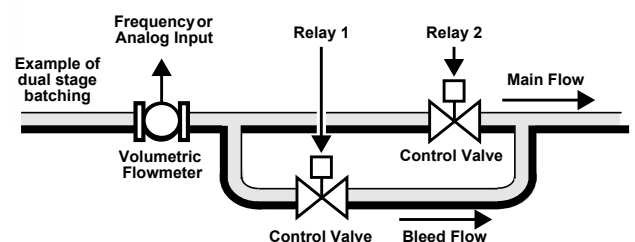

Displayed Information

The front panel display shows the current values of the input variables and the results of the calculations. A list of the variables for this application and their type (total or rate) is shown at the end of this document.

The instrument can be supplied with a real-time clock for storage of up to 1000 transactions with time and date stamps.

Communications

There are two communication ports available as follows:

- COM-1 RS-232 port
- COM-2 RS-485 port (optional) or Ethernet (optional)

The ports are available for remote data reading, printouts and for initial application loading of the instrument.

Isolated Outputs

The opto-isolated outputs can be configured to retransmit any main menu variable or provide various error/control signals (flow error, pump control, end-of-batch, etc.). One output is standard, a second output is available as an option.

Relay Outputs

The relay outputs 1 and 2 are used to control the flow of product for each delivery. These contacts are normally open and can be used to drive external relays, valves, pump circuits etc. The advanced option provides another two relays that can be used as fully programmable alarms for any rate type variable.

Software Configuration

The instrument can be programmed to suit the particular application needs and the flexible I/O can be assigned as required. Program settings can be changed either via the front panel (depending on assigned access levels) or via the 500 Series Program Manager (500-PM software).

The instrument stores all set-up parameters, totals and logged data in non-volatile memory with at least 30 years retention.

Dimension Drawings

Part Number

515.XXXXXX-BC01
see **Product Codes** to select required features

Default Application software:
515-BC01-000000

Terminal Designations

Terminal Label	Designation	Comment
1 FINP	1+	Frequency Input 1+
3 SG	-	Signal ground
11 AINP3	+	Analog Input ch 3 (+)
12	-	Analog Input ch 3 (-)
15 Vo	+	8-24 volts DC output
16 G	-	DC Ground
17 Vi	+	DC power input
18 SH	E	Shield terminal
19 RS485	+	RS485 (+)
20 COM-2	-	RS485 (-)
21 port	G	RS485 ground
22	1+	Switch 1
23	2+	Switch 2
24 LOGIC	3+	Switch 3
25 INPUTS	4+	Switch 4
26	C-	Signal ground
27 OUT1	+	Output ch 1 (+)
28	-	Output ch 1 (-)
29 OUT2	+	Output ch 2 (+)
30	-	Output ch 2 (-)
31	RC	Relay Common 1-2
32	R1	Relay 1
33	R2	Relay 2
34	R3	Relay 3
35	R4	Relay 4
36	RC	Relay common 3-4
E AC	E	Mains ground
N MAINS	N	Mains neutral
A	A	Mains active
RS232 COM-1 port		9-pin serial port

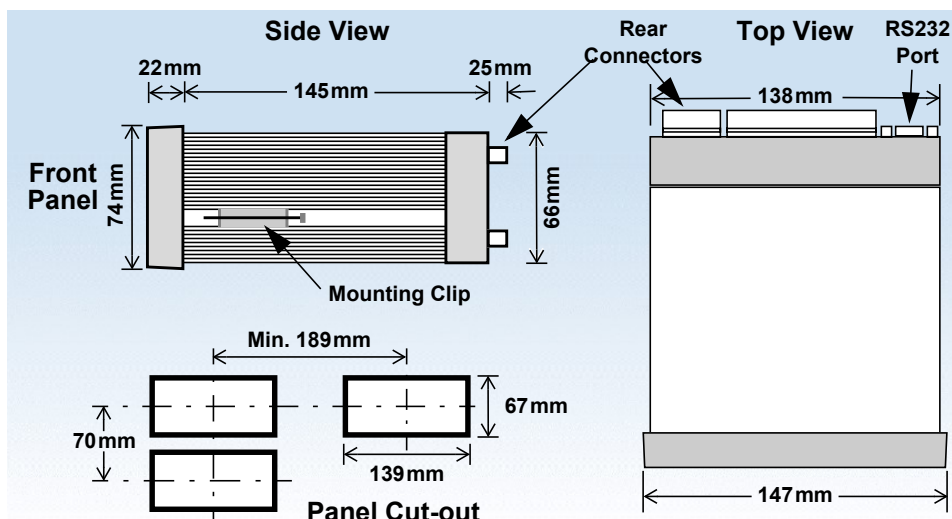

Specifications

Operating Environment

Temperature	+5°C to +40°C (standard - no coating) -20°C to +60°C (with conformal coating) -30°C to +60°C (ExD housing with heater)
Humidity	0 to 95% non condensing (conformal coating) 5% to 85% non condensing (no coating)
Power Supply	100-240 V AC (+/-10%) 50-60 Hz (+/-10%) or 12-28 V DC
Consumption	10W (max) Overvoltage category II
Protection	Sealed to IP65 (Nema 4X) when panel mounted
Dimensions (panel option)	147mm (5.8") width 74mm (2.9") height 170mm (6.6") depth (behind the panel)

Display

Type	Backlit LCD with 7-digit numeric display and 11-character alphanumeric display
Digits	15.5mm (0.6") high
Characters	6mm (0.24") high
LCD Backup	Last data visible for 15min after power down
Update Rate	0.3 second

Non-volatile Memory

Retention	> 30 years
Data Stored	Setup, Totals and Logs

Approvals

Electrical & Interference	UKCA, CE, CSA compliance
Enclosure	Ex d Enclosure - ATEX & IECEx available for hazardous area (CSA Pending). Field Mount Enclosure - UKCA, CE, CSA safe area weather proof enclosure. Other - RoHS compliant

Real Time Clock (Optional)

Battery Type	3 volts Lithium button cell - For Issue 7 option card, type CR2450N manufactured by Renata only - For conformal coated 'C' version, type BR2032 manufactured by Panasonic only - For non-conformal coated versions, type BR2032 and CR2032 manufactured by Panasonic or Sony
Battery Life	5 years (typical)

Frequency Input (General)

Range	0 to 10kHz for Pulse input type 0 to 5 kHz for Coil & NPS input types
Overvoltage	30V maximum
Update Time	0.3 sec
Cutoff frequency	Programmable
Configuration	Pulse, coil or NPS input
Non-linearity	Up to 10 correction points

Pulse

Signal Type	CMOS, TTL, open collector, reed switch
Threshold	Signals switch below 1.3 & above 2 volts

Coil

Signal Type	Turbine and sine wave
Sensitivity	15mV minimum amplitude (typical)

NPS

Signal Type	NPS sensor to Namur standard
--------------------	------------------------------

Analog Input (General)

Overcurrent	100mA absolute maximum rating (30mA for 4-20mA inputs)
Update Time	< 1.0 sec
Configuration	4-20mA, 0-5V and 1-5V input
Non-linearity	Up to 20 correction points (some inputs)

4-20 mA Input

Impedance	100 Ohms (to common signal ground)
Accuracy	0.05% full scale (20°C) 0.1% (full temperature range, typical)

0-5 or 1-5 Volts Input

Impedance	10MOhms (to common signal ground)
Accuracy	0.05% full scale (20°C) 0.1% (full temperature range, typical)

Logic Inputs

Signal Type	CMOS, TTL, open collector, reed switch
Overvoltage	30V maximum

Relay Output

No. of Outputs	2 relays plus 2 optional relays
Voltage	250 volts AC, 30 volts DC maximum (solid state relays use AC only)
Current	3A maximum - mechanical relays 1.5A maximum - solid state relays

Communication Ports

Ports	COM-1 RS-232 port COM-2 RS-485 or Ethernet port (optional)
Baud Rate	2400 to 19200 baud
Parity	Odd, even or none
Stop Bits	1 or 2
Data Bits	8
Protocols	ASCII, Modbus RTU, Modbus TCP/IP (Ethernet Port), Printer

Transducer Supply

Voltage	8 to 24 volts DC, programmable
Current	70mA @ 24V, 120mA @ 12V maximum
Protection	Power limited output

Isolated Output

No. of Outputs	2 configurable outputs
Configuration	Pulse/Digital or 4-20mA output

Pulse/Digital Output

Signal Type	Open collector
Switching	200mA, 30 volts DC maximum
Saturation	0.8 volts maximum
Pulse Width	Programmable: 10, 20, 50, 100, 200 or 500ms

4-20 mA Output

Supply	9 to 30 volts DC external
Resolution	0.05% full scale
Accuracy	0.05% full scale (20°C) 0.1% (full temperature range, typical)

Important: Specifications are subject to change without notice.

Ordering Information

Product Codes

Model	Supplementary Code	Description
515	- BC01	
Enclosure	1	Panel mount enclosure
	2/7	Field mount enclosure (NEMA 4X / IP66) (7 specifies heater included)
	3/5	Explosion proof Ex d (IECEX/ATEX), metric glands (5 specifies heater included)
	4/6	Explosion proof Ex d (CSA), NPT glands (6 specifies heater included)
Output Options	0	4 logic inputs, 1 isolated output, 2 relays (only relay type 1 is available), RS232 (DB9) communication port
	1	4 logic inputs, 2 isolated outputs, 4 relays, real-time clock data logging, RS232 (DB9) and RS485 communication ports
	2	4 logic inputs, 2 isolated outputs, 4 relays, real-time clock data logging, RS232 (DB9) & Ethernet communication ports
Relay Type	1	Electromechanical relays only
	2	2 electromechanical relays (1-2) and 2 solid state relays (3-4)
	3	Solid state relays only
Power Supply	U	Inputs for 12-28VDC and 100-240 VAC, 50-60Hz (Previous Models: A = 110/120 VAC, E = 220/240 VAC)
	D	Input for 12-28VDC power only
Display Panel Option	S	Standard option (now with backlight & LCD backup) (original Full option: F, with Infra-Red comms, no longer available)
PCB Protection	C	Conformal coating - required for maximum environmental operating range. Recommended to avoid damage from moisture and corrosion.
	N	None - suitable for IEC standard 654-1 Climatic Conditions up to Class B2 (Heated and/or cooled enclosed locations)
Application Pack Number	BC01	Defines the application software to be loaded into the instrument

Example full product part number is 515.111USC-BC01 (this is the number used for placing orders).

Main Menu Variables

Main Menu Variables	Default Units	Preferred Units	Variable Type
Volume	L		Total
Volume Flowrate	L/min		Rate
Preset Quantity *	---		---

* These variables are logged and can be printed but are not shown in main menu.



500 Series in BZC Ex d enclosure

www.contrec.co.uk



Contrec Ltd
Riverside, Canal Road
Sowerby Bridge, West Yorkshire
HX6 2AY United Kingdom
Tel: +44 1422 829944
Email: sales@contrec.co.uk

Contrec - USA, LLC
916 Belcher Drive
Pelham, Alabama
AL 35124 United States
Tel: +1 (205) 685 3000
Email: contrec@contrec-usa.com

Contrec Systems Pty Ltd
5 Norfolk Avenue
Ringwood, Victoria 3134
Melbourne Australia
Tel: +61 413 505 114
Email: info@contrec.com.au