

Batch Controller

Model 430D

Features

- Accepts pulse and frequency flow signals
- Scaled pulse output
- Overrun compensation
- One or two stage valve control
- Optional RS232/422/485 interfaces for computers and printers
- Remote start/stop
- No-signal alarm
- Ticket printing with time and date
- Displays batch total, preset quantity, flow rate and accumulated total



Overview

The 430D Batch Controller is suited to applications where precise measurement and control of variable batch quantities is required.

The instrument is extremely flexible and easy to operate. Batches can be started, paused, stopped and reset via four operational keys and batch quantities and calibration parameters are entered via a 12 key numeric keypad.

Batch Total, Flow Rate, Accumulated Total and Preset Value can all be displayed in engineering units on the green LED display.

The 430D will accept most frequency and pulse signals, including mV outputs from turbine flowmeters, and two-wire proximity switch outputs.

Batch Features

Automatic Overrun Compensation

Based on previous batches, the 430D will automatically compensate for any overrun which may be caused by slow closing valves.

Batch Limit

A maximum batch quantity can be programmed during set-up, so that the operator cannot enter a batch size that exceeds this limit.

Signal Time-out

If the flow signal cuts out midway through a batch, the output relays are de-energised, and an alarm signalled via an open collector output.

Remote Start/Stop

Remote push-button switches can be connected to the rear terminal strip to duplicate the four operational switches: RUN; Rate; Reset and STOP.

Auto Restart

The 430D can be programmed to automatically restart the batch after a preset time delay.

Count Up/Down

The instrument can be programmed to count up from zero, or to count down from the batch quantity.

End of Batch

An End of Batch signal is provided via an open collector transistor output.

Batch Controller

Model 430D

Computer/Printer Interface

An RS232 and RS422/485 option is available for interfacing to computers and printers. The interface allows the Batch Controller to be fully controlled from a computer.

Software drivers are included for a number of printers and can print a ticket with time and date, a sequential delivery/batch number and the batch and accumulated totals. An optional header for the ticket can also be printed.

Rate Totaliser Mode

The 430D can be configured during calibration to operate as a Rate Totaliser as distinct from a batch controller.

In this mode the RUN, STOP and Batch Set keys perform no function. The Rate key is used to toggle the display between Rate and Resettable Total.

By pressing and holding the Accum. key, whenever the instrument is not in data entry mode, the Accumulated Total will be displayed.

Versatile performance options

The instrument will operate from 14 to 28V dc or from 110 to 220V ac mains.

The fascia is fully watertight to Nema 4X (IP65) and is resistant to most chemicals.

A total conversion feature enables the rate to be displayed in one engineering unit (eg. gallons/minute) and the totals to be displayed in another engineering unit (eg. barrels).

The standard instrument is supplied as panel mount. Field enclosures are optionally available.

Operation

Keypad operations are straightforward and four LED's indicate the operational status at all times.

The unique keypad simplifies operation, making the instrument suited to use by operators with minimal training.

Four operational keys and a full numeric keypad on the front fascia, enable the batch quantity to be set, and batch operations to be started, paused, stopped or reset.

Setting Batch Quantity

To set a batch quantity, the Batch Set key is pressed, and then the quantity is entered via the numeric keys. Once set, the Batch Set key is again pressed to return to Run mode.

The batch quantity can only be set while the instrument is in a non-operational state such as when the batch is complete or paused.

Once set, the batch quantity will be retained in non-volatile memory and will not alter until changed by the user.

To check the batch quantity while a batch is in progress press the Batch Set key.

Starting a Batch

To start the batch the RUN key is pressed. The Run LED will light and the instrument will begin to totalise from zero or, if programmed for the count down mode, the display will decrement from the batch quantity.

Stopping a Batch

The batch can be stopped at any time by pressing the STOP key. To continue the batch press the RUN key, or to abort the batch press the STOP key again.

When the batch has been interrupted the Pause LED will light. If the batch is aborted the Stop LED will light.

Resetting a Batch

The instrument can be programmed to reset in either of two ways.

By manually pressing the Reset key, at the end of a batch, the Batch Total will be reset to zero (if programmed to count up) or to the preset quantity (if programmed to count down).

If Auto Reset is programmed, however, the Batch Total will automatically reset when the RUN key is pressed.

One or two stage valve control

Two output relays provide control for single or dual stage valve operation. The first relay will energise at the start of the batch, and de-energise when the batch is complete.

The second relay can be programmed to energise at a set time after the start, and to de-energise at a set quantity prior to completion of the batch. This feature enables a slow startup and slow shutdown of the flow.

The Batch Controller can also be programmed to count up from zero or down from the batch quantity.

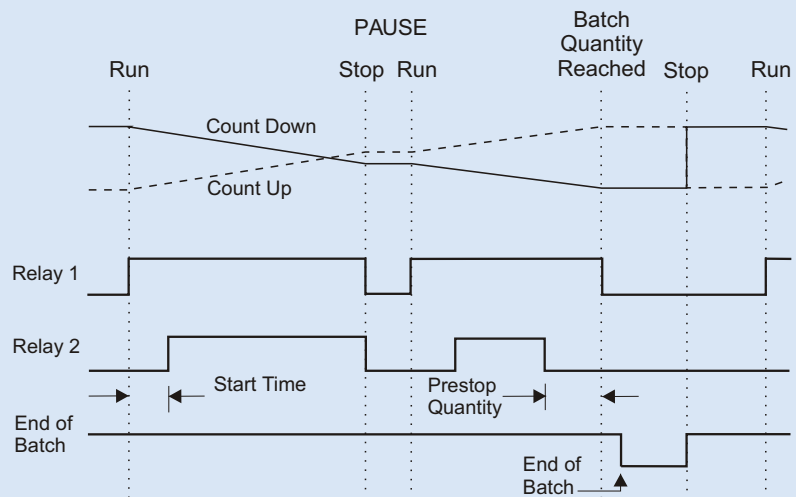

Two Stage Valve Control

General

Display	6 digit 0.4" (10.2mm) high green LED.
Display Update Rate	0.25s.
Data Retention	All set-up parameters and totals are stored in a non-volatile memory with 10 years retention.
Transducer Supply	8-24V dc field adjustable, 50mA maximum.
Power Requirements	
dc Supply:	14-28V dc, 450mA typical current (no options).
ac Supply:	ac mains set internally to 95-135V ac or 190-260V ac.
Operating Temp	0 to 55°C.

Relay Outputs

Maximum Power	1250VA.
Maximum Voltage	250V ac, 30V dc.
Maximum Current	5 Amps.

Pulse Output

Pulse Width	10ms (negative going pulse).
Max Duty Cycle	49 pulses per second.
Scaling	The pulse output is scaled and outputs one pulse each time the accumulated total increments.

Approvals

Electrical Interference	ETL (US) approved to UL 508 and CSA. CE Compliance.
--------------------------------	---

Frequency Input

Frequency Range	
Minimum:	0.25Hz on Rate, 0Hz on Total.
Maximum:	10kHz.
Scaling Range	0.1000 to 50,000.
Switching Threshold	2.5V (except for Namur proximity and coil input types).
Maximum Input Voltage	50V peak.
Input Impedance	
Logic Signal, CMOS, Pulse:	100KΩ.
Open Collector or Reed Switch:	10KΩ.
Namur Proximity (set dc out to 8V):	1KΩ.
Switch or Reed Switch with debounce circuit (200Hz max.):	10KΩ.
Coil (20mV P-P min):	100KΩ.
Coil - low impedance (22mV P-P min.):	2.4KΩ.

Optional Enclosures

Field Enclosures	IP67 (Nema 4X).
-------------------------	-----------------

Important: Specifications are subject to change without notice.

Dimension Drawings

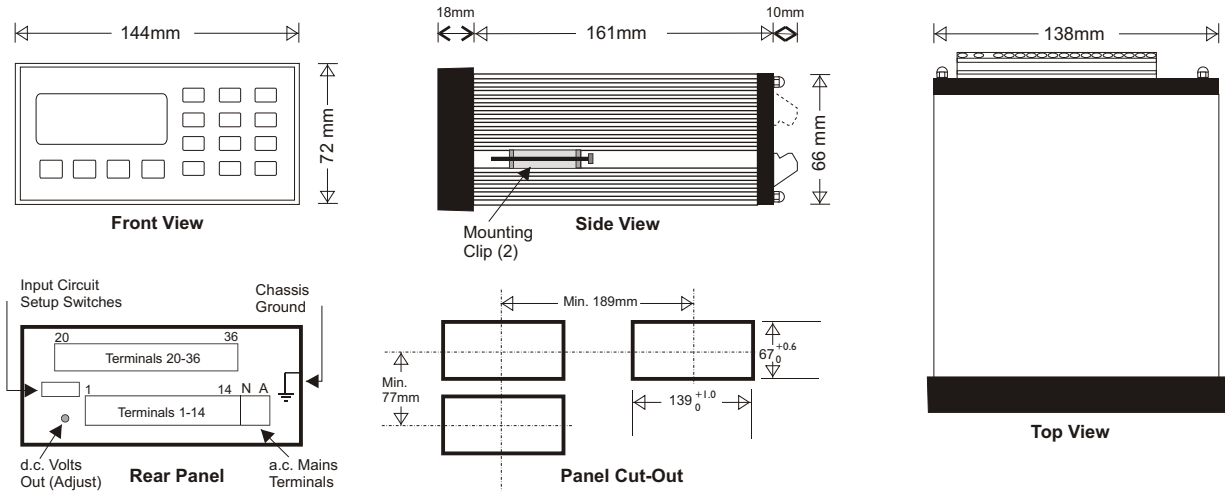

Terminal Descriptions

Standard Terminal Connections			
No.		No.	
1	Calibration Link	8	Flow Common (-)
2	Signal Ground	9	Flow Pulse Input
3	Remote RUN Switch	10	Pulse Out
4	Remote Rate Switch	11	dc Power Out (8-24V)
5	Remote Reset Switch	12	dc Ground
6	Remote STOP Switch	13	dc Power Input
7	Flow Alarm	14	Not to be used

RS232/422/485 Option	
No.	
20	RS232 Signal Ground
21	RS232 Data In
22	RS232 Data Out
23	RS422/485 (-) Data Out
24	RS422/485 (+) Data Out
25	RS422/485 (-) Data In
26	RS422/485 (+) Data In
27	RS232 CTS

Relay Output & Switches	
No.	
28	Not to be used
29	Not to be used
30	End of Batch/Pump Control Signal
31	Relay 2 - Normally Open
32	Relay 2 - Normally Closed
33	Relay 2 - Common
34	Relay 1 - Normally Open
35	Relay 1 - Normally Closed
36	Relay 1 - Common

Ordering Information

When specifying please indicate model(s) required using the following method.

430 D . 1 0 E

<p>Basic Model</p> <p>Input Type Pulse or frequency input with signal conditioner - D</p> <p>Mounting Options Panel Mount - 1 Field Mount enclosure - N</p>	<p>Power Supply E - 220-240V ac A - 110-120V ac D - 12-28V dc J - 100V ac</p> <p>Communications 0 - No option 2 - RS232/422/485</p>
---	---

contrec

Distributed by:

Contrec Pty Ltd
22 Hall Street Hawthorn East, Melbourne 3123 AUSTRALIA
Tel: +61 3 9822 8966 Fax: +61 3 9822 8329 Email: sales@contrec.com.au
a Delft Instruments company

Contrec - USA, LLC
916 Belcher Drive Pelham AL 35124 USA
Tel: (205) 685 3000 Fax: (205) 685 3001 Email: contrec@contrec-usa.com

Contrec Europe Limited
PO Box 436 Sowerby Bridge, West Yorkshire HX6 3YA, UK
Tel: +44 1422 829 940 Fax: +44 1422 829 941 Email: sales@contrec.co.uk

Website: www.contrec.com.au