

# Gas & Steam Flow Computer

Model 415

## Features

- Displays mass flow, corrected volume and energy flow
- Accepts 4-20mA and frequency flow inputs
- Temperature and pressure compensation
- Dual ranged DP transmitter inputs
- Operates from 14-28V dc or ac mains
- Simplified programming
- Data logging output



## Overview

The 415 Steam and Gas Flow Computer incorporates the following compensation equations for gas and vapours:

- **Ideal Gas Law** using temperature and pressure correction, but where compressibility correction is not required.
- **General Gases** where compressibility is calculated using the Redlich-Kwong<sup>1</sup> state equation. This equation is suitable for gases which have known properties, and information on common industrial gases is provided in the operating manual.
- **Natural Gas** using the NX-19<sup>2</sup> equation to calculate super compressibility.
- **Steam Equations** for both saturated and superheated steam. Mass and energy flow rates are calculated using standard equations to determine the specific weight and enthalpy of steam.

## RTD or 4-20mA temperature outputs

The backlit alphanumeric display simplifies programming and provides a clear indication of all parameters, as well as engineering units. The 415 is fully programmable and all operating parameters are entered via the front panel keypad.

The instrument is available with direct RTD input (415R) or with 4-20mA temperature input (415A). Both accept a 4-20mA pressure input.

## Wide range of flowmeter inputs

Inputs from a wide range of flowmeters are accepted, including vortex, turbine, orifice plate, averaging pitot tubes, wedges and target flowmeters. Also, where two differential pressure transmitters are used across an orifice or similar device, to increase the measured flow range, both DP transmitter inputs are accepted and scaled separately with automatic crossover.

# Gas & Steam Flow Computer

## Model 415

A scaled output, suitable for driving remote totalisers, is a standard feature. Options include an isolated 4-20mA retransmission, high and low flow alarms and an RS232/422 output which will operate on either the mass, corrected volume or energy outputs, depending on which value is programmed as the default display.

### RS232/422 output enables data logger operation

The RS232/422 option will output all parameters displayed and has the unique ability to print flow rates and totals at programmable time intervals. This enables the 415 to function as a data logger when used in conjunction with a printer or other storage device.

Protocols are provided for standard roll and column printers as well as for computer interfaces and a real time clock provides time and date. The totals can be programmed to reset via the front panel, after each print or at 24:00 hours.

## Flowmeter Inputs

The 415 accepts most flowmeter inputs including:

- **Frequency** producing flowmeters such as vortex, turbine or positive displacement.
- **Volumetric** flowmeters with 4-20mA outputs such as vortex or turbines with a frequency to current converter on the output.
- **Differential Pressure** devices such as orifice plates, averaging pitot tubes, wedges, cones, elbows or target flowmeters, where a square law relationship applies.
- **Linear Differential Pressure** devices where the 4-20mA output is directly proportional to the flow rate.

- **Dual Range (Stacked) Differential Pressure Transmitters** where two separately spanned transmitters are used across a common flow device such as an orifice (both square and linear inputs).
- **Non-Linear Differential Pressure** devices such as laminar flow tubes or VA meters. A 20 point correction curve can be programmed to compensate for any non-linearities in the flowmeter.

## Parameters Displayed

Information is displayed in a number of windows which can be selected using the **DISPLAY** key.

### General

**Flow rate** of the mass, corrected volume or energy is displayed in units per day, hour, minute or second.

**Total** of the mass, corrected volume or energy. A reset key on the front panel enables totals to be reset, or the key can be disabled during setup. Totals are displayed with 8 digits.

### Gas Flow

Corrected volume at base conditions (m<sup>3</sup> or ft<sup>3</sup>)

Mass (kg or lbs)

Temperature (°C or °F)

Pressure (kPa or psi) in absolute or gauge

Compressibility Z, for general gases

Super compressibility  $F_{pv}$  for natural gas

### Steam Flow

Mass (kg or lbs)

Energy (MJ or Btu x 1000)

Temperature (°C or °F)

Pressure (kPa or psi) in absolute or gauge

Specific weight in dm<sup>3</sup>/kg

Specific enthalpy in kJ/kg

## General

<b>Display</b>	2 line x 20 character (5.5mm high) alphanumeric backlit LCD.
<b>Keypad</b>	Sealed membrane keypad with four keys.
<b>Transducer Supply</b>	8-24V dc field adjustable, 65mA max.
<b>Power Requirements</b>	
dc Supply:	14 to 28V dc, 300mA typical (no options).
ac Supply:	ac mains set internally to 95-135V ac or 190-260V ac.
<b>Operating Temperature</b>	0 to 55°C.
<b>Facia Sealing</b>	IP65 (Nema 4X) watertight.

## Approvals

<b>Electrical Interference</b>	ETL (US) approved to UL508 and CSA. CE Compliance.
<b>Enclosure</b>	CENELEC, FM, CSA and SAA approved enclosures available for hazardous areas.

## Frequency Input

<b>Range</b>	
Minimum:	0.25Hz on Rate, 0Hz on Total.
Maximum:	10KHz.
<b>Input Circuits</b>	Accepts most sine, logic and proximity switch inputs.
<b>K-factor Range</b>	0.1000 to 999,999.
<b>Non-Linear Correction</b>	Up to 10 correction points.

## 4-20mA Inputs

<b>Input Types</b>	Flow (2 ranges), pressure and temperature.
<b>Input Impedance</b>	250 ohms.
<b>Measurement Range</b>	
Pressure:	0 kPa abs (0 psia) to 100,000 kPa abs (10,000 psia).
Temperature:	-273°C (-459.4°F) to 1200°C (2192°F).
<b>Span (flow)</b>	999,999.
<b>Accuracy</b>	0.05%.
<b>Circuit</b>	250 ohm resistors connected to a common signal ground (current sinking).
<b>Non-Linear Correction</b>	A 20 point curve can be applied to the flow input.

## RTD Input (Model 415R)

<b>Type</b>	Platinum PT100.
<b>Range</b>	-100°C (-148°F) to 200°C (392°F). (Note a wider temperature range can be handled via a 4-20mA input.)
<b>Accuracy</b>	0.1°C.
<b>Linearity</b>	The non-linearity of the RTD is internally compensated for.

## Pressure Input

<b>Type</b>	Absolute or gauge.
<b>Span</b>	Absolute or gauge pressure is programmable at 4mA and 20mA.
<b>Atmospheric</b>	If a gauge pressure sensor is used, the atmospheric pressure is programmable.

## Pulse Output

<b>Pulse Width</b>	10ms (negative going pulse).
<b>Duty Cycle</b>	49 pulses/sec max.
<b>Output</b>	Open collector transistor will sink 100mA max. (Note: Suitable for driving remote counters or PLC's.)

## RS232/422 Option

<b>Type</b>	Both RS232 and RS422 are provided. (Note: When using the RS422, multi-point communication (RS485) can be implemented with up to 32 instruments connected to a common bus.)
<b>Function</b>	Printer and computer protocols are fully programmable.
<b>Printer</b>	A print is initiated on each reset or at a programmable time interval. (Note: Protocols are provided for roll & column printers.)
<b>Computer</b>	An ASCII based protocol enables all displayed parameters to be read and the totals to be reset.
<b>Baud rate</b>	300 to 9600.
<b>Data Bits</b>	7 or 8.
<b>Parity</b>	None, Odd or Even.
<b>Data Logging</b>	Output generated at intervals of once a minute to once every 24 hours. The totals can be programmed to reset on each print or at 24:00 hours. A real time clock is provided to give time and date on each output.
<b>Time</b>	

## 4-20mA Output Option

<b>Function</b>	Outputs flow rate in mass, corrected volume or energy. The 4 and 20mA points can be programmed to provide a fully scaled output.
<b>Resolution</b>	10 bits.
<b>Accuracy</b>	Better than 0.1%.
<b>Maximum Load</b>	500 ohms internally powered. 950 ohms from external 24V dc.
<b>Isolation</b>	Output is isolated.

## Relay Output Option

<b>Function</b>	High and low flow rate alarms based on the flow rate in mass, corrected volume or energy.
<b>Maximum Ratings</b>	
Power:	250VA.
Voltage:	250V ac, 30V dc.
Current:	5 Amps.

## Ideal Gas

<b>Display</b>	
Corrected Volume:	m <sup>3</sup> or ft <sup>3</sup> .
Mass:	kg or lbs.
<b>Temperature Range</b>	-273°C (-450°F) to 800°C (1472°F).
<b>Pressure Range</b>	0 kPa abs (0 psia) to 100,000 kPa abs (10,000 psia).

## General Gas

<b>Gases</b>	Handles most gases for which the critical temperature, pressure and specific gravity are known.
<b>Compressibility</b>	Calculated using the Redlich-Kwong <sup>1</sup> equation.
<b>Temperature Range</b>	-273°C (-450°F) to 800°C (1472°F) (RTD has a more limited range).
<b>Pressure Range</b>	0 kPa abs (0 psia) to 100,000 kPa abs (10,000 psia).

## Natural Gas

<b>Calculations</b>	Uses NX-19 <sup>2</sup> equation to calculate super compressibility $F_{pv}$ .
<b>Temperature Range</b>	-40°C (-40°F) to 115°C (240°F).
<b>Pressure Range</b>	101.325 kPa abs (14.69 psia) to 34,380 kPa abs (4985 psia).
<b>Specific Gravity Range</b>	0.554 to 1.000.
<b>Carbon Dioxide Nitrogen</b>	0 to 15% mole.

<sup>1</sup> Redlich & Kwong, "An equation of State", Chem Rev., vol 44, p233, 1949.  
<sup>2</sup> Par Research Project NX-19, "Extension of Range of Super Compressibility Tables", American Gas Association, 1962.

## Steam

<b>Calculations</b>	Uses 1967 IFC Formulation (ASME) equations to calculate specific weight and enthalpy of steam.
<b>Types</b>	Saturated and Superheated.
<b>Temperature Range</b>	20°C (68°F) to 800°C (1472°F) (RTD has a more limited range.)
<b>Pressure Range</b>	1 kPa abs (1 psia) to 100,000 kPa abs (10,000 psia).
<b>Saturated Steam</b>	When measuring saturated steam, it is possible to omit either the pressure or temperature sensor since, on the saturated line, there is a corresponding pressure for all temperatures.

*Important: Specifications are subject to change without notice.*

## Dimension Drawings

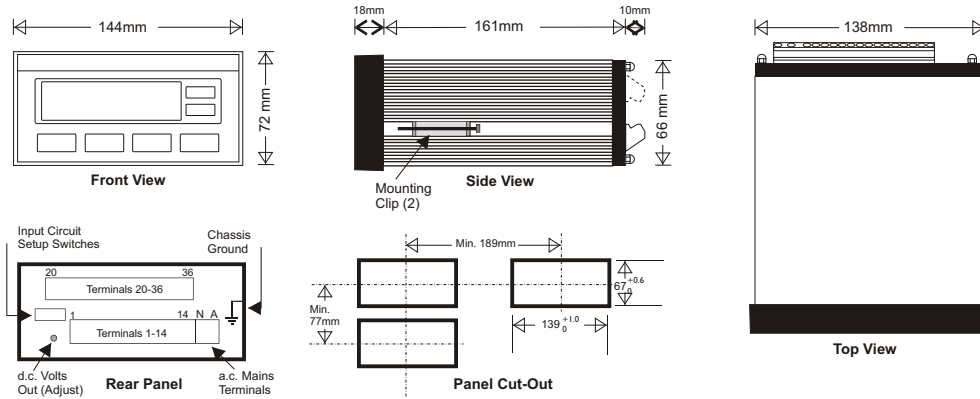

## Terminal Descriptions

Terminals Common to all Models	415A	415R	RS232/422 Option	Isolated 4-20mA Output Option	High & Low Relay Alarm Option
No. 1 Calibration	No. 3 Flow 1 (4-20mA)	Flow 1 (4-20mA)	No. 20 RS232 Signal Ground	No. 20 Not Used	No. 31 High - Normally Open
No. 2 Switch Common	No. 4 Temp. (4-20mA)	PT100 (+)	No. 21 RS232 Data In	No. 21 0 Volts	No. 32 High - Normally Closed
No. 11 DC Power Out	No. 5 Reset Switch	PT100 Signal (+)	No. 22 RS232 Data Out	No. 22 0-10 Volts Out	No. 33 High - Common
No. 12 DC Ground	No. 6 Display Switch	PT100 Signal (-)	No. 23 RS422 (-) Data Out	No. 23 -12 Volts	No. 34 Low - Normally Open
No. 13 DC Power In	No. 7 Pressure (4-20mA)	Pressure (4-20mA)	No. 24 RS422 (+) Data Out	No. 24 I (-)	No. 35 Low - Normally Closed
	No. 8 Flow Common	Flow Common	No. 25 RS422 (-) Data In	No. 25 I (+)	No. 36 Low - Common
	No. 9 Flow Pulse Input	Flow Pulse Input	No. 26 RS422 (+) Data In	No. 26 +15 Volts	
	No. 10 Pulse Out	Pulse Out	No. 27 RS232 CTS	No. 27 Not Used	
	No. 14 Flow 2 (4-20mA)	PT100 (-)			

## Ordering Information

When specifying please indicate model(s) required using the following method.

**415 R . 1 0 E C**

<b>Basic Model</b>		<b>Special Options</b>
<b>Temperature Input</b>		0 - No option
4-20mA - A		C - Conformal Coating
PT100 RTD - R		G - German language version
<b>Mounting</b>		<b>Power Supply</b>
Panel - 1		E - 240V ac
Field - N		A - 110V ac
Explosionproof - 3		D - 14-28V dc
		J - 100V ac
		<b>Standard Options</b>
		0 - No options
		1 - Isolated 4-20mA output
		2 - RS232/422
		3 - High/Low alarms
		4 - 4-20mA and alarms
		5 - RS232/422 and alarms



## Distributed by:

Contrec Europe Limited  
 Riverside, Canal Road, Sowerby Bridge, HX6 2AY, UK  
 Tel: +44 (0)1422 829940 Fax: +44 (0)1422 829941  
 E-mail: sales@contrec.co.uk Web: www.contrec.co.uk

Contrec - USA, LLC  
 916 Belcher Drive, Pelham, AL 35124 USA  
 Tel: +001 (205) 685 3000 Fax: +001 (205) 685 3001  
 E-mail: contrec@contrec-usa.com

Contrec Systems P/L  
 5 Norfolk Ave, Ringwood, VIC 3134, Melbourne, Australia  
 Tel: +61 413 505 114 E-mail: pchaston@optusnet.com.au